

Technical catalogue

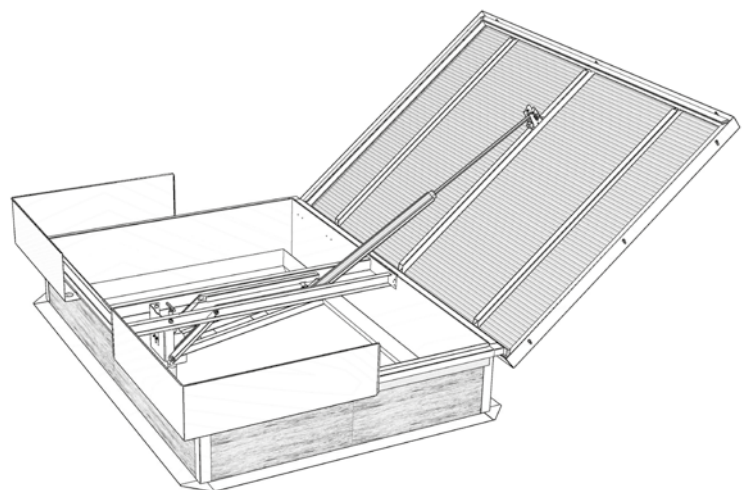
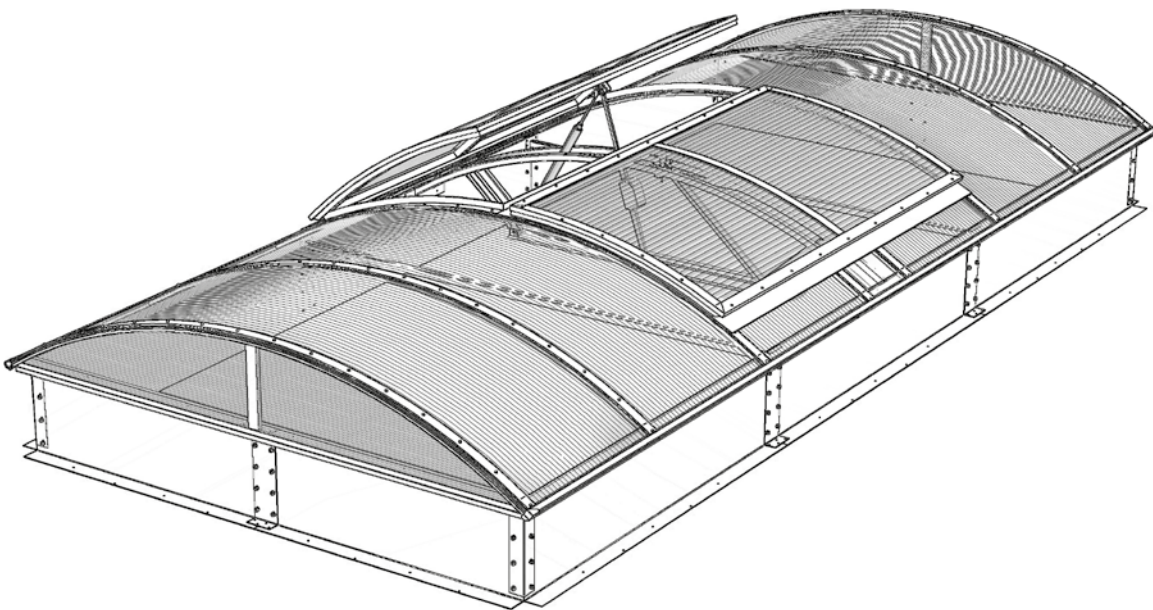

mcr PROLIGHT

**SMOKE VENTS, FIXED SKYLIGHTS,
ROOF HATCHES, VENTILATION VENTS
CONTINUOUS ROOFLIGHTS WITH SMOKE VENTS**

Smoke exhaust, heat removal and skylight systems
Technical Catalogue 2022

„MERCOR“ S.A. with registered office in Gdańsk reserves the right to revise this Technical Catalogue 2022 at any time, without providing a reason. Moreover, any revisions made do not necessitate (at any stage) informing any persons using this Technical Catalogue 2022.

„MERCOR“ S.A. also reserves that the contents of this Technical Catalogue 2022 do not constitute a trade offer as defined in art. 66 of Polish Civil Code.

Graphic design and digital typesetting:
„MERCOR“ S.A. – Export Department
2022 MERCOR Gdańsk

1	MCR PROLIGHT SMOKE VENTS	> 6
1.1	Single-leaf smoke vents with straight base – type C, E	> 7
1.2	Double-leaf smoke vents with straight base – type DVP	> 13
1.3	Single-leaf smoke vents with skew base – type NG-A	> 17
1.4	Double-leaf smoke vents with skew base - type DVPS	> 25
2	FIXED SKYLIGHTS, ROOF HATCHES, VENTILATION VENTS	> 29
2.1	Fixed skylights with straight base – type C, E	> 30
2.2	Fixed skylights with skew base – type NG-A	> 34
2.3	Roof hatches with straight – type C, E	> 39
2.4	Roof hatches with skew base – type NG-A	> 42
2.5	Ventilation vents with straight base – type C, E	> 45
2.6	Ventilation vents with skew base – type NG-A	> 49
3	INSTALLATION OF VENTS, SKYLIGHTS AND HATCHES	> 54
3.1	Smoke vent with steel straight base fixed onto reinforced concrete structure	> 54
3.2	Smoke vent with steel straight base fixed onto steel roof	> 54
3.3	Smoke vent with steel straight base fixed onto steel plinth	> 56
3.4	Smoke vent with plinth type straight base fixed onto reinforced concrete plinth	> 56
3.5	Smoke vent with steel skew base fixed onto steel structure	> 57
4	SMOKE VENTS AND VENTILATION VENTS, SKYLIGHTS AND HATCHES GLAZING	> 58
4.1	Multi-chamber polycarbonate panel (PCA)	> 59
4.2	PMMA acrylic dome	> 60
4.3	PC solid polycarbonate dome	> 61
4.4	ALU sandwich panel	> 62
4.5	ALU envelope cover with multi-chamber polycarbonate	> 62
4.6	Single-layer acrylic dome (PMMA)/ solid polycarbonate (PC) dome and multi-chamber polycarbonate panel (PCA)	> 63
4.7	Double-layer acrylic dome (PMMA)/ solid polycarbonate (PC) dome and multi-chamber polycarbonate panel (PCA)	> 64
4.8	B _{roof} (t1) multi-chamber polycarbonate panel + polyester panel	> 65
5	ADDITIONAL EQUIPMENT FOR VENTS, SKYLIGHTS AND HATCHES	> 66
5.1	Smoke vent with roof access option	> 68
5.2	Wind deflectors	> 70
5.3	Inlet deflector	> 71
5.4	Anti-burglar grid	> 72
5.5	Safety net	> 72
5.6	Overlay type base - N type	> 73
5.7	Limit switch	> 74
5.8	Mechanic opening system	> 75
6	CONTINUOUS ROOFLIGHTS WITH SMOKE VENTS AND/OR VENTILATION VENTS	> 77
6.1	Arch shaped continuous rooflights	> 78
6.2	Smoke vents integrated in arch shaped continuous rooflights	> 80
6.3	Triangular shaped continuous rooflights	> 89
6.4	Pyramid skylights	> 93
6.5	Igloo skylights	> 97
7	INSTALLATION OF CONTINUOUS ROOFLIGHT BASES	> 98
7.1	Installation of continuous rooflight bases on steel structure	> 98
7.2	Installation of continuous rooflight bases on reinforced concrete structure	> 99
7.3	Installation of continuous rooflight standard bases on reinforced concrete steel or wooden plinth	> 99
8	CONTINUOUS ROOFLIGHT GLAZING	> 100
8.1	Single glazing	> 102
8.2	Multi-layer glazing	> 102
9	ADDITIONAL EQUIPMENT FOR CONTINUOUS ROOFLIGHTS	> 109
9.1	Wind deflectors	> 110
9.2	Anti-burglar grid	> 110
9.3	Safety net	> 111
9.4	Limit switch	> 111

Technical catalogue

2022

Dear Clients,

We are pleased to present to you our technical catalogue for smoke exhaust, heat removal and skylight systems. This publication presents in detail „MERCOR“ S.A. products, starting from smoke vents and skylights, through smoke curtains, new generation roof hatches, all the way to the comprehensive review of our control systems. We believe the form in which we present our offer facilitates finding all the necessary information on the individual product series, their components, as well as detailed specifications for the elements of each product offered.

Every merchandise delivered from „MERCOR“ S.A. to the Client is meticulously controlled in accordance with the highest quality assurance standards, and undergoes a number of approval tests. We take pride in providing safety through our business.

We invite you to see the full extent of our offer.



„MERCOR“ S.A. - Export Department



1. | Smoke vents mcr PROLIGHT

Smoke vents are the main element of any natural smoke exhaust system; their purpose is to extract smoke, fire fumes and heat energy from enclosed areas to the outside of the building. They allow to:

- » maintain emergency routes in a state of moderate smoke level, permitting effective evacuation,
- » carry out rescue operations by locating fire,
- » reduce the risk of damaging or destroying the building structure by a sudden decrease in temperature.

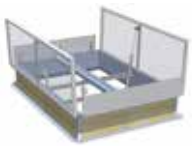
		C/ E vent	DVP vent	NG-A vent	DVPS vent
Parameters					
Product classification	Certificate of Conformity 1396-CPR-0040 as per EN 12101-2	<ul style="list-style-type: none"> » Re300 or Re50 – operational reliability during 300/50 cycles of opening and closing to smoke exhaust position, and 10 000 cycles to ventilation position (double function vent), » WL1500 or WL750 – operational certainty of vents under wind stress equivalent to 1500 Pa or 750 Pa (depending on type, size and accessories), » T(-25) or T(00) – resistance of vents to low temperature of -25°C or 0°C, » B300 or B600 – resistance of vents to high temperature of 300°C or 600°C (depending on type and accessories), » SL: 250, 550, 750, 950, 1300, 1600, 2000 - operational certainty of vents under snow load N/m²² 			
Control	Pneumatic (smoke exhaust)	•	•	•	•
	Electric 230V~ (ventilation)	•	•	•	•
	Electric 24V- (smoke exhaust + daily ventilation)	•	•	•	•
	Pneumatic (gas springs) (smoke exhaust and/or ventilation)	•	•	-	-
Glazing	multi-chamber polycarbonate panel	•	•	•	•
	acrylic dome (*)	•	-	•	-
	solid polycarbonate dome (*)	•	-	•	-
	ALu sandwich panel (**)	•	•	•	•
	classification B _{ROOF} (t1) (***)	•	•	•	•
	multi-chamber polycarbonate panel and envelope cover(*)	•	•	•	•
multi-chamber polycarbonate panel and single or double-layer acrylic dome or solid polycarbonate dome(*)	•	-	•	-	

(*) Applies to selected vent sizes.

(**) ALU sandwich panel: aluminum - thermal insulation - aluminum

(***) B_{ROOF}(t1) glazing (multi-chamber polycarbonate of thickness ≥ 10 mm and polyester panel)

1.1. | Single-leaf smoke vents with straight base – type C, E

1.1.1 | Technical description of standard

- » classification as per Certificate of Conformity in accordance with EN 12101-2 (CE Certificate),
- » type C smoke vents (squared) and type E (rectangular) smoke vents for flat and pitched roofs covered with roofing paper or PVC membrane,
- » dimensional range of smoke vents:
 - C type (squared): 100x100 cm ÷ 200x200 cm
 - E type (rectangular): 100x120 cm ÷ 200x250 cm
- » straight base of height 300 mm or 500 mm made of galvanized steel sheet of 1.25 mm thickness
- » bottom part of the base has a circumferential flange of width 100 mm, through which the base is fitted to the roof structure,
- » upper part of base has shape enabling water runoff,
- » base standard: mcr Prolight: thermal insulation of base made of mineral wool of thickness 20 mm; heat transfer coefficient $U=1.41 \text{ W/m}^2\text{K}$, circumferential strip in the upper part of base, made of galvanized steel sheet, used for fixing flashings,
- » leaf glazing: multi-chamber polycarbonate panel, acrylic dome, solid polycarbonate dome, sandwich panel, multi-chamber polycarbonate panel and single or double-layer acrylic dome or solid polycarbonate dome, multi-chamber polycarbonate panel with aluminum envelope cover and glazing of B_{ROOF} (t1) class (details in section 4),
- » leaf opening angle $\geq 140^\circ$,
- » hinges fixing the leaf to base installed at lengthwise side of vent,
- » smoke exhaust control: pneumatic, electric 24V-, mechanic,
- » ventilation control: electric 230V~,
- » optional increased active smoke exhaust area (Aa) through the use of wind deflectors and/or inlet deflector.

1.1.2 | Smoke vent design

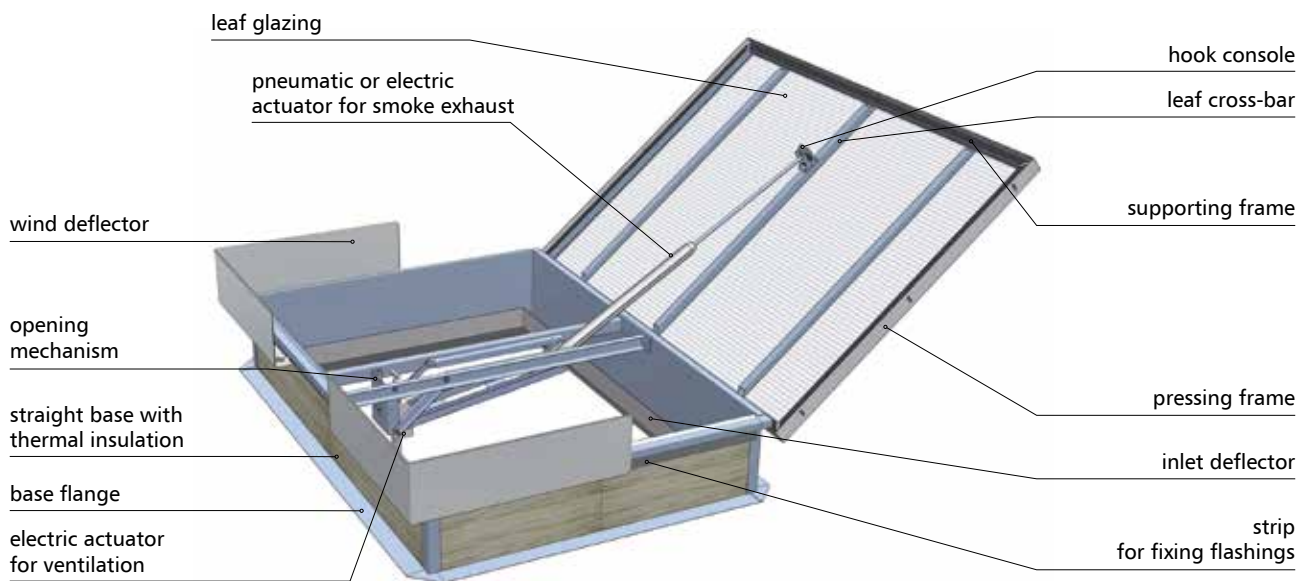

Fig.1 Design of mcr PROLIGHT E smoke vent equipped with wind deflectors and inlet deflector, with pneumatic actuator for smoke exhaust and electric actuator for ventilation

1.1.3 | Non-standard options

- » vent elements painted to any RAL color - applies to wind deflectors, pressing frame, envelope cover, inlet deflector and base,
- » thermal insulation of base: PIR panel of 30 mm thickness, heat transfer coefficient $U=0.68 \text{ W/m}^2\text{K}$,
- » base made of aluminium sheet of 2,00 mm thickness,
- » custom dimensions of clear opening of vent base,
- » custom base height within 200 mm(*) ÷ 700 mm,
- » custom width of circumferential flange of base,
- » circumferential strip for fixing roof flashings made of PVC coated metal sheet,
- » base, inlet deflector and opening mechanism made of stainless steel,
- » broad range of optional accessories,
- » roof access option available..

(*) Base height below 300 mm available only if a plinth is designed for the vent, ensuring total height (vent+plinth) of min. 300 mm.

1.1.4 | Technical drawings

- » Smoke vent with wind deflectors and inlet deflector, with pneumatic control for smoke exhaust and electric actuator for ventilation

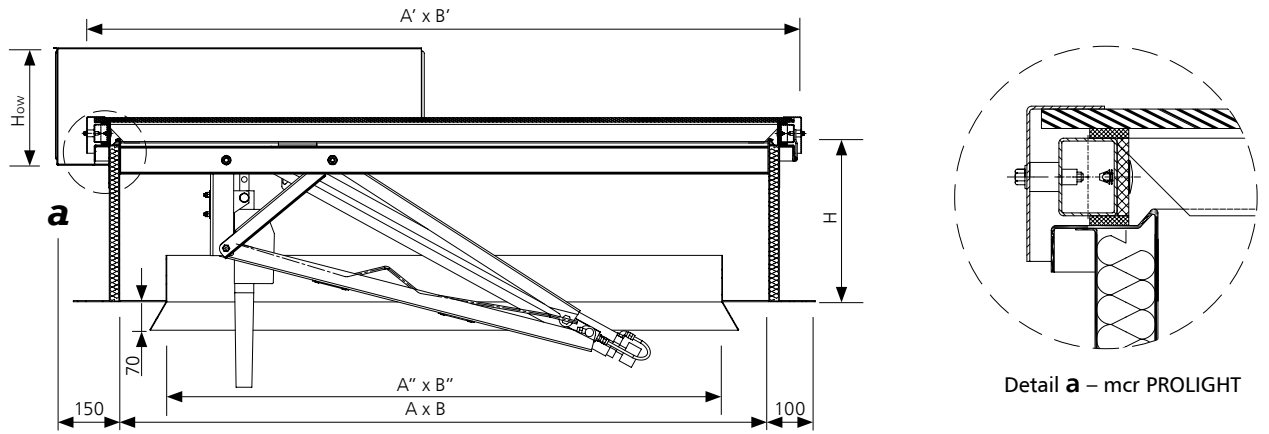

Fig.2 Section B-B of mcr PROLIGHT C or E smoke vent in closed position, dimensions in [mm]

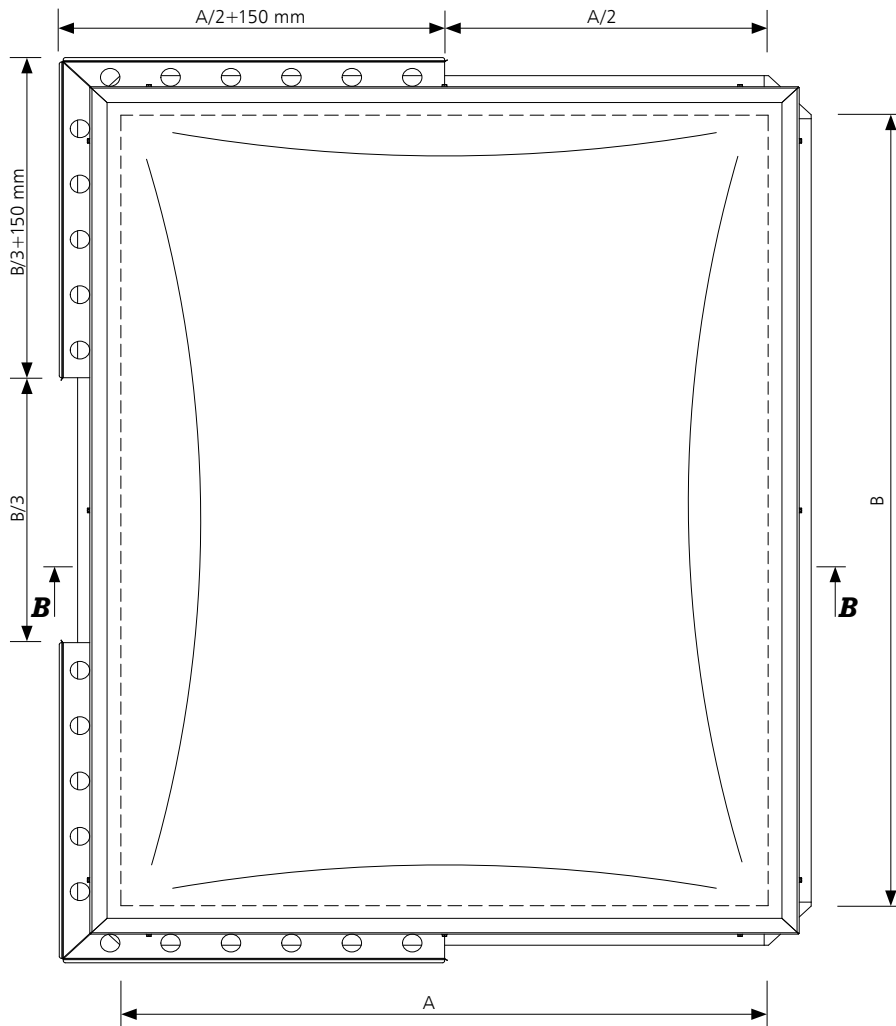

Fig.3 Top view of mcr PROLIGHT C or E smoke vent in closed position, dimensions in [mm]

A, B – nominal dimensions [mm], clear opening of smoke vent
 A', B' – total dimensions of smoke vent leaf $A' = A + 135 \text{ mm}$, $B' = B + 135 \text{ mm}$
 A'', B'' – clear opening of inlet deflector $A'' = A - 200 \text{ mm}$, $B'' = B - 200 \text{ mm}$
 H – smoke vent base height [mm]
 H_{ow} – wind deflector height $100 \text{ mm} \leq H_{ow} \leq 450 \text{ mm}$

1.1.5.1 | Technical details

VENT Type	NOMINAL DIMENSIONS (*)	BASE OF MIN. H=500 mm			BASE OF MIN. H=300 mm			ESTIMATED WEIGHT(**)
		ACTIVE AREA A _a [m ²]			ACTIVE AREA A _a [m ²]			
	A x B	STANDARD	WITH WIND DEFLECTORS	WITH WIND DEFLECTORS AND INLET DEFLECTOR	STANDARD	WITH WIND DEFLECTORS	WITH WIND DEFLECTORS AND INLET DEFLECTOR	[kg]
	[mm]	WITHOUT WIND DEFLECTORS AND INLET DEFLECTOR			WITHOUT WIND DEFLECTORS AND INLET DEFLECTOR			
C 100	1000 x 1000	0,72	0,71	0,79	0,64	0,67	0,75	76
C 110	1100 x 1100	0,85	0,85	0,96	0,74	0,80	0,92	82
C 115	1150 x 1150	0,91	0,93	1,04	0,79	0,87	1,01	85
C 120	1200 x 1200	0,98	1,01	1,14	0,85	0,95	1,09	88
C 125	1250 x 1250	1,05	1,09	1,25	0,91	1,03	1,19	91
C 130	1300 x 1300	1,13	1,17	1,35	0,96	1,12	1,28	94
C 135	1350 x 1350	1,20	1,26	1,46	1,04	1,20	1,40	102
C 140	1400 x 1400	1,27	1,35	1,57	1,10	1,27	1,51	105
C 150	1500 x 1500	1,44	1,55	1,80	1,22	1,46	1,73	117
C 155	1550 x 1550	1,51	1,63	1,92	1,30	1,56	1,85	120
C 160	1600 x 1600	1,61	1,74	2,05	1,36	1,66	1,97	124
C 170	1700 x 1700	1,76	1,97	2,34	1,50	1,88	2,23	140
C 180	1800 x 1800	1,94	2,20	2,62	1,65	2,11	2,49	147
C 190	1900 x 1900	2,13	2,45	2,92	1,81	2,35	2,82	154
C 195	1950 x 1950	2,24	2,55	3,08	1,86	2,43	2,97	157
C 200	2000 x 2000	2,32	2,68	3,24	1,96	2,56	3,12	161
E 100/120	1000 x 1200	0,85	0,84	0,95	0,74	0,79	0,91	82
E 100/130	1000 x 1300	0,92	0,91	1,03	0,79	0,86	0,99	85
E 100/140	1000 x 1400	0,98	0,98	1,11	0,85	0,92	1,06	88
E 100/150	1000 x 1500	1,04	1,05	1,19	0,90	0,99	1,14	95
E 100/160	1000 x 1600	1,10	1,12	1,26	0,94	1,06	1,22	98
E 100/180	1000 x 1800	1,22	1,24	1,44	1,03	1,19	1,37	104
E 100/190	1000 x 1900	1,27	1,31	1,52	1,07	1,25	1,44	107
E 100/200	1000 x 2000	1,34	1,38	1,60	1,12	1,32	1,54	110
E 100/210	1000 x 2100	1,40	1,45	1,68	1,16	1,39	1,62	113
E 100/220	1000 x 2200	1,45	1,52	1,76	1,19	1,45	1,69	116
E 100/230	1000 x 2300	1,50	1,59	1,84	1,22	1,50	1,77	119
E 100/240	1000 x 2400	1,56	1,66	1,92	1,27	1,56	1,85	122
E 100/250	1000 x 2500	1,63	1,73	2,00	1,30	1,63	1,93	125
E 110/200	1100 x 2000	1,45	1,52	1,76	1,21	1,43	1,69	114
E 115/200	1150 x 2000	1,50	1,59	1,84	1,24	1,50	1,77	116
E 120/140	1200 x 1400	1,13	1,16	1,34	0,97	1,11	1,28	94
E 120/150	1200 x 1500	1,21	1,24	1,44	1,03	1,19	1,39	102
E 120/170	1200 x 1700	1,35	1,41	1,63	1,14	1,33	1,57	108
E 120/180	1200 x 1800	1,43	1,49	1,73	1,19	1,40	1,66	111
E 120/200	1200 x 2000	1,56	1,66	1,92	1,30	1,56	1,85	117
E 120/210	1200 x 2100	1,63	1,71	2,02	1,34	1,64	1,94	120
E 120/220	1200 x 2200	1,69	1,80	2,11	1,40	1,72	2,03	123
E 120/240	1200 x 2400	1,81	1,96	2,30	1,47	1,87	2,22	130
E 120/250	1200 x 2500	1,89	2,04	2,40	1,53	1,95	2,31	133
E 125/250	1250 x 2500	1,94	2,13	2,50	1,56	2,03	2,41	134
E 130/150	1300 x 1500	1,29	1,35	1,56	1,09	1,27	1,50	105
E 130/160	1300 x 1600	1,35	1,44	1,66	1,16	1,35	1,60	108
E 130/180	1300 x 1800	1,52	1,61	1,87	1,26	1,52	1,80	180
E 130/190	1300 x 1900	1,58	1,68	1,98	1,33	1,61	1,90	117
E 130/200	1300 x 2000	1,66	1,77	2,08	1,38	1,69	2,00	121
E 130/220	1300 x 2200	1,80	1,94	2,29	1,49	1,86	2,20	127
E 130/230	1300 x 2300	1,88	2,03	2,39	1,52	1,94	2,30	130
E 130/250	1300 x 2500	2,02	2,21	2,60	1,63	2,11	2,50	136

VENT Type	NOMINAL DIMENSIONS (*)	BASE OF MIN. H=500 mm			BASE OF MIN. H=300 mm			ESTIMATED WEIGHT(**)
		ACTIVE AREA A _a [m ²]			ACTIVE AREA A _a [m ²]			
	A x B	STANDARD	WITH WIND DEFLECTORS	WITH WIND DEFLECTORS AND INLET DEFLECTOR	STANDARD	WITH WIND DEFLECTORS	WITH WIND DEFLECTORS AND INLET DEFLECTOR	[kg]
	[mm]	WITHOUT WIND DEFLECTORS AND INLET DEFLECTOR			WITHOUT WIND DEFLECTORS AND INLET DEFLECTOR			
E 140/150	1400 x 1500	1,37	1,45	1,68	1,16	1,37	1,62	114
E 140/180	1400 x 1800	1,61	1,71	2,02	1,36	1,64	1,94	123
E 140/200	1400 x 2000	1,76	1,90	2,24	1,46	1,82	2,16	130
E 140/250	1400 x 2500	2,14	2,38	2,80	1,75	2,28	2,70	145
E 150/160	1500 x 1600	1,51	1,63	1,92	1,30	1,56	1,85	120
E 150/180	1500 x 1800	1,70	1,84	2,16	1,43	1,76	2,08	126
E 150/200	1500 x 2000	1,86	2,04	2,43	1,56	1,95	2,31	133
E 150/210	1500 x 2100	1,95	2,14	2,55	1,61	2,05	2,43	136
E 150/240	1500 x 2400	2,20	2,45	2,88	1,80	2,34	2,77	146
E 150/250	1500 x 2500	2,25	2,55	3,00	1,84	2,44	2,89	149
E 160/180	1600 x 1800	1,79	1,96	2,33	1,50	1,87	2,22	130
E 160/190	1600 x 1900	1,88	2,07	2,46	1,58	1,98	2,34	133
E 160/200	1600 x 2000	1,95	2,18	2,59	1,63	2,08	2,46	137
E 160/220	1600 x 2200	2,15	2,39	2,85	1,76	2,29	2,75	143
E 160/230	1600 x 2300	2,21	2,50	2,98	1,84	2,39	2,87	146
E 160/240	1600 x 2400	2,30	2,61	3,11	1,88	2,50	3,00	149
E 180/200	1800 x 2000	2,16	2,45	2,92	1,80	2,34	2,81	154
E 180/220	1800 x 2200	2,34	2,65	3,21	1,94	2,53	3,09	160
E 180/240	1800 x 2400	2,55	2,89	3,50	2,07	2,76	3,37	167
E 180/250	1800 x 2500	2,61	3,02	3,65	2,16	2,88	3,51	170
E 190/200	1900 x 2000	2,24	2,55	3,08	1,86	2,43	2,96	158
E 195/200	1950 x 2000	2,30	2,61	3,16	1,91	2,50	3,04	159
E 195/220	1950 x 2200	2,49	2,87	3,47	2,06	2,75	3,35	166
E 195/250	1950 x 2500	2,78	3,27	3,95	2,29	3,12	3,80	176
E 200/250	2000 x 2500	2,85	3,35	4,05	2,35	3,20	3,90	177

(*) Intermediate smoke vent dimensions between the values specified in the table are possible. The size of active smoke exhaust area for those dimensions is determined through linear interpolation method

(**) Estimated weight specified for smoke vent of base height 500 mm, of standard configuration with multi-chamber polycarbonate panel glazing of 16 mm thickness, with pneumatic control.

1.1.6 | Smoke vents control

For correct operation, smoke vents as well as smoke exhaust & ventilation vents require connecting to devices controlling their opening and closing. A set of such devices constitutes a system for smoke exhaust control or smoke exhaust and ventilation control. Depending on the type of devices used, it may be designed as a:

- » pneumatic smoke exhaust control system,
- » 24V electric smoke exhaust control system with ventilation function,
- » pneumatic and electric control system; the pneumatic part is responsible for smoke exhaust, while the 230V~ electric part - for ventilation.

Smoke exhaust control systems are activated as follows:

1. automatic – through a thermo switch installed in the vent (pneumatic system), or by optical smoke sensors (electric system),
2. manual – by a release of CO₂ cartridges in alarm box (pneumatic system), or by operation of RPO emergency pushbutton (electric system),
3. FAS signal – by external impulse from fire alarm system (FAS) sent to an electromagnet installed in the alarm box (pneumatic system), or directly to smoke exhaust control unit (electric system).

1.1.6.1 | Smoke vents control

VENT Type	PNEUMATIC CONTROL(*)			ELECTRIC CONTROL(**)	
	PNEUMATIC ACTUATOR		MIN. CO ₂ CARTRIDGE CAPACITY – SL 950 [G] [g]	POWER CONSUMPTION [A] BY ELECTRIC ACTUATOR FOR CLASS	
	STROKE [mm]	DIAMETER [mm]		SL 250	SL 550
C 100	550	50	24	1,6	2,6
C 110	550	50	24	1,6	2,6
C 115	550	50	24	1,6	4,0
C 120	550	50	40	2,0	4,0
C 125	550	50	40	2,0	4,0
C 130	550	50	40	2,6	4,0
C 135	750	50	40	2,6	6,0
C 140	750	50	40	2,6	6,0
C 150	750	50	55	4,0	6,0
C 155	750	50	55	4,0	6,0
C 160	750	50	55	6,0	-
C 170	1050	63	55	6,0	-
C 180	1050	63	120	6,0	-
C 190	1050	63	120	8,0	-
C 195	1050	63	120	8,0	-
C 200	1050	63	120	8,0	-
E 100/120	550	50	24	1,6	2,6
E 100/130	550	50	24	1,6	2,6
E 100/140	550	50	24	1,6	2,6
E 100/150	550	50	24	1,6	4,0
E 100/160	550	50	40	2,0	4,0
E 100/180	550	50	40	2,0	4,0
E 100/190	550	50	40	2,0	4,0
E 100/200	550	50	40	2,0	4,0
E 100/210	550	50	40	2,6	4,0
E 100/220	550	50	40	2,6	4,0
E 100/230	550	50	40	2,6	6,0
E 100/240	550	50	40	2,6	6,0
E 100/250	550	50	40	2,6	6,0

VENT Type	PNEUMATIC CONTROL(*)			ELECTRIC CONTROL(**)	
	PNEUMATIC ACTUATOR		MIN. CO ₂ CARTRIDGE CAPACITY – SL 950 [G] [g]	POWER CONSUMPTION [A] BY ELECTRIC ACTUATOR FOR CLASS	
	STROKE [mm]	DIAMETER [mm]		SL 250	SL 550
E 115/200	550	50	40	2,6	6,0
E 120/140	550	50	40	2,0	4,0
E 120/150	550	50	40	2,6	4,0
E 120/170	550	50	40	2,6	6,0
E 120/180	550	50	40	2,6	6,0
E 120/200	550	50	40	2,6	6,0
E 120/210	550	50	55	4,0	6,0
E 120/220	550	50	55	4,0	6,0
E 120/240	550	50	55	4,0	6,0
E 120/250	550	50	55	4,0	6,0
E 125/250	550	50	55	4,0	8,0
E 130/150	550	50	40	2,6	6,0
E 130/160	550	50	40	2,6	6,0
E 130/180	550	50	55	4,0	6,0
E 130/190	550	50	55	4,0	6,0
E 130/200	550	50	55	4,0	6,0
E 130/220	550	50	55	4,0	6,0
E 130/230	550	50	55	4,0	8,0
E 130/250	550	50	80	4,0	8,0
E 140/150	750	50	40	2,6	6,0
E 140/180	750	50	55	4,0	6,0
E 140/200	750	50	55	4,0	8,0
E 140/250	750	50	80	6,0	8,0
E 150/160	750	50	55	4,0	8,0
E 150/180	750	50	55	4,0	8,0
E 150/200	750	50	80	6,0	8,0
E 150/210	750	50	80	6,0	8,0
E 150/240	750	50	80	6,0	8,0
E 150/250	750	50	80	6,0	-
E 160/180	750	50	80	6,0	-
E 160/190	750	50	80	6,0	-
E 160/200	750	50	80	6,0	-
E 160/220	750	50	80	6,0	-
E 160/230	750	50	80	6,0	-
E 160/240	750	50	80	6,0	-
E 180/200	1050	63	120	6,0	-
E 180/220	1050	63	120	8,0	-
E 180/240	1050	63	120	8,0	-
E 180/250	1050	63	120	8,0	-
E 190/200	1050	63	120	8,0	-
E 195/200	1050	63	120	8,0	-
E 195/220	1050	63	120	8,0	-
E 195/250	1050	63	120	-	-
E 200/250	1050	63	120	-	-

(*) Pneumatic control available in classes: SL 250, SL 550, SL 750, SL 1300, SL 1600 and SL 2000 at special request (applies to selected vent sizes).

(**) Electric control available in classes: SL 750, SL 950, SL 1300 and SL 1600 at special request (applies to selected vent sizes).

Power consumption specified in the table applies to smoke vent with multi-chamber polycarbonate glazing.

1.2. | Double-leaf smoke vents with straight base – type DVP

1.2.1 | Technical description of standard

- » classification as per Certificate of Conformity in accordance with EN 12101-2 (CE Certificate),
- » type DVP smoke vents (double-leaf) for flat and pitched roofs covered with roofing paper or PVC membrane,
- » dimensional range of smoke vents:
 - 120x250 cm ÷ 300x300 cm
- » straight base of height 300 mm or 500 mm made of galvanized steel sheet of 1.25 mm thickness
- » bottom part of the base has a circumferential flange of width 100 mm, through which the base is fitted to the roof structure,
- » upper part of base has shape enabling water runoff,
- » thermal insulation of base and water trough made of mineral wool of thickness 20 mm; heat transfer coefficient $U=1.41\text{W/m}^2\text{K}$,
- » circumferential strip in the upper part of base, made of galvanized steel sheet, used for fixing roof work,
- » leaf glazing: multi-chamber polycarbonate panel, sandwich panel, multi-chamber polycarbonate panel with aluminum envelope cover and glazing with B_{ROOF} (t1) classification (details in section 4),
- » leaf opening angle $\geq 90^\circ$,
- » hinges fixing the leaf to base installed at lengthwise side of vent,
- » smoke exhaust control: pneumatic, electric 24V-, oleoneumatic,
- » ventilation control: electric 230V~,
- » optional increased active smoke exhaust area (Aa) through the use of wind deflectors and/or inlet deflector.

1.2.2 | Smoke vent design

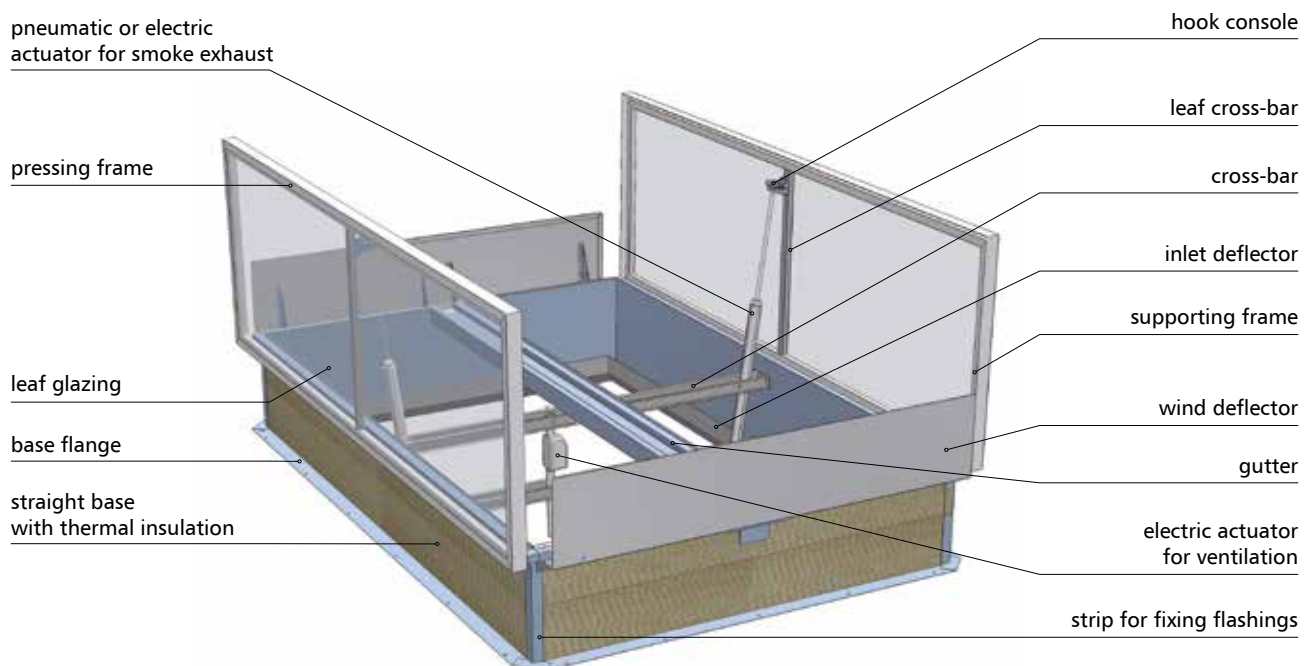

Fig.4 Design of mcr PROLIGHT DVP smoke vent equipped with wind deflectors and inlet deflector, with pneumatic actuators for smoke exhaust and electric actuator for ventilation.

1.2.3 | Non-standard options

- » vent elements painted to any RAL color - applies to pressing frame, wind deflectors, inlet deflector and base - powder coating up to 1800x3000 [mm] dimensions,
- » thermal insulation of base made of PIR panel of 30 mm thickness, heat transfer coefficient $U=0.68\text{ W/m}^2\text{K}$,
- » base made of aluminium sheet of 2,00 mm thickness,
- » custom dimensions of clear opening of vent base,
- » custom base height within 200 mm(*) ÷ 700 mm,
- » custom width of circumferential flange of base,
- » circumferential strip for fixing roof flashings made of PVC coated metal sheet,
- » base, inlet deflector and cross-bar in stainless steel,
- » broad range of optional accessories.

(*) Base height below 300 mm available only if a plinth is designed for the vent, ensuring total height (vent+plinth) of min. 300 mm.

1.2.4 | Technical drawings

- » Smoke vent with wind deflectors and inlet deflector, with pneumatic control (for smoke exhaust and electric actuator for ventilation)

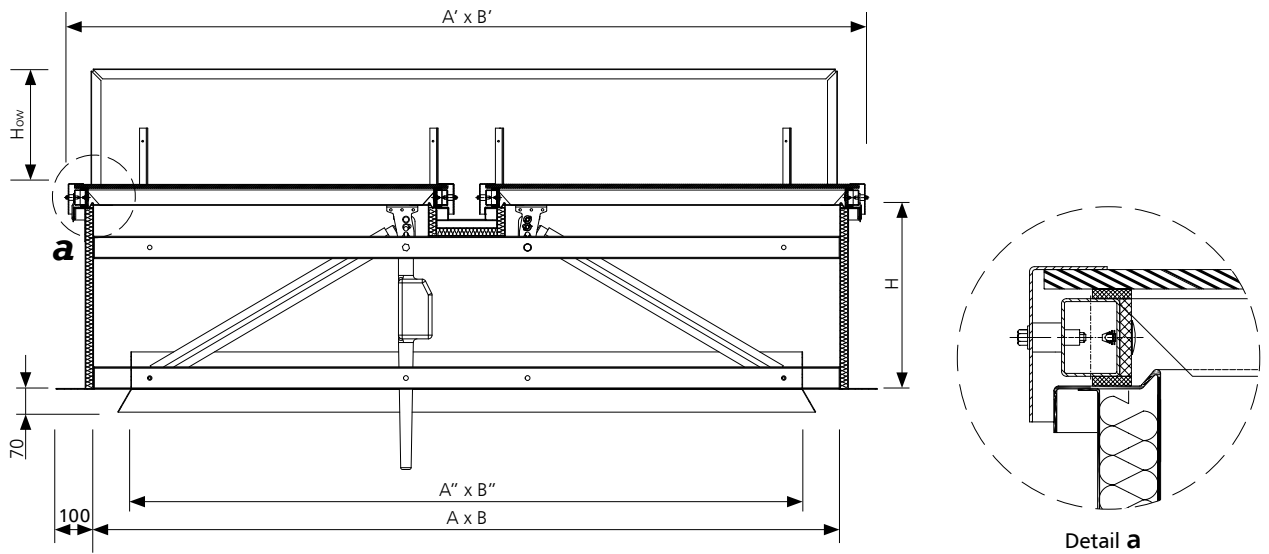

Fig.5 Section B-B of mcr PROLIGHT DVP smoke vent in closed position, dimensions in [mm]

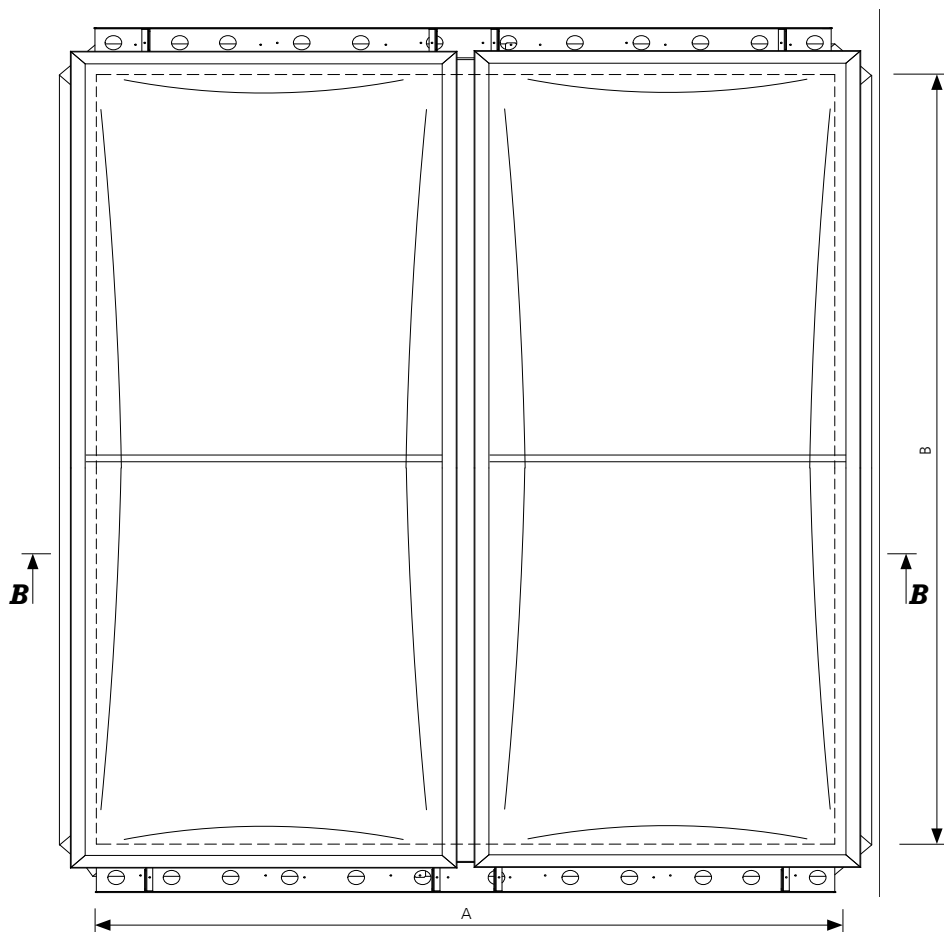

Fig.6 Top view of mcr PROLIGHT DVP smoke vent in closed position, dimensions in [mm]

- A, B – nominal dimensions [mm], clear opening of smoke vent
- A', B' – total dimensions of smoke vent leaf $A' = A + 135$ mm, $B' = B + 135$ mm
- A'', B'' – clear opening of inlet deflector $A'' = A - 100$ mm, $B'' = B - 100$ mm
- H – smoke vent base height [mm]
- H_{ow} – wind deflector height $100 \text{ mm} \leq H_{ow} \leq 370 \text{ mm}$

1.2.5 | Technical details

VENT Type	NOMINAL DIMENSIONS (*)	BASE OF MIN. H=500 mm			BASE OF MIN. H=300 mm			ESTIMATED WEIGHT(**)
		ACTIVE AREA A_a [m ²]			ACTIVE AREA A_a [m ²]			
	A x B	STANDARD	WITH WIND DEFLECTORS	WITH WIND DEFLECTORS AND INLET DEFLECTOR	STANDARD	WITH WIND DEFLECTORS	WITH WIND DEFLECTORS AND INLET DEFLECTOR	[kg]
	[mm]	WITHOUT WIND DEFLECTORS AND INLET DEFLECTOR			WITHOUT WIND DEFLECTORS AND INLET DEFLECTOR			
DVP 120/250	1200 x 2500	1,90	1,90	2,04	1,62	1,83	2,07	159
DVP 120/300	1200 x 3000	2,30	2,30	2,45	1,98	2,20	2,48	181
DVP 150/250	1500 x 2500	2,20	2,43	2,63	1,85	2,32	2,63	170
DVP 150/300	1500 x 3000	2,65	2,93	3,15	2,25	2,79	3,15	193
DVP 160/160	1600 x 1600	1,51	1,62	1,74	1,28	1,56	1,74	135
DVP 160/250	1600 x 2500	2,28	2,60	2,80	1,92	2,48	2,80	176
DVP 160/280	1600 x 2800	2,55	2,91	3,14	2,15	2,82	3,14	189
DVP 160/300	1600 x 3000	2,74	3,17	3,41	2,30	3,02	3,41	198
DVP 180/160	1800 x 1600	1,64	1,84	1,96	1,38	1,76	1,99	144
DVP 180/180	1800 x 1800	1,83	2,07	2,24	1,52	2,01	2,24	153
DVP 180/250	1800 x 2500	2,48	2,97	3,20	2,07	2,84	3,20	185
DVP 180/280	1800 x 2800	2,77	3,33	3,58	2,32	3,18	3,58	199
DVP 180/300	1800 x 3000	2,97	3,56	3,83	2,48	3,40	3,83	208
DVP 200/200	2000 x 2000	2,16	2,60	2,80	1,80	2,48	2,80	169
DVP 200/240	2000 x 2400	2,59	3,17	3,41	2,16	3,02	3,41	188
DVP 200/250	2000 x 2500	2,70	3,30	3,55	2,25	3,15	3,55	193
DVP 200/280	2000 x 2800	3,02	3,70	4,03	2,52	3,53	3,98	207
DVP 200/300	2000 x 3000	3,18	3,96	4,32	2,67	3,78	4,32	216
DVP 220/220	2200 x 2200	2,57	3,19	3,44	2,13	3,05	3,44	189
DVP 220/240	2200 x 2400	2,75	3,48	3,80	2,32	3,33	3,75	199
DVP 220/250	2200 x 2500	2,86	3,63	3,96	2,37	3,47	3,91	203
DVP 240/240	2400 x 2400	2,94	3,80	4,15	2,42	3,63	4,15	206
DVP 240/250	2400 x 2500	3,06	4,02	4,32	2,52	3,84	4,32	211
DVP 250/250	2500 x 2500	3,19	4,19	4,50	2,63	4,00	4,50	217
DVP 250/300	2500 x 3000	3,75	5,03	5,48	3,15	4,80	5,40	240
DVP 300/300	3000 x 3000	4,32	6,12	6,66	3,60	5,85	6,57	264

(*) Intermediate smoke vent dimensions between the values specified in the table are possible. The size of active smoke exhaust area for those dimensions is determined through linear interpolation method.

(**) Estimated weight specified for smoke vent of base height 500 mm, of standard configuration with multi-chamber polycarbonate panel glazing of 16 mm thickness, with pneumatic control.

1.2.6 | **Smoke vents control**

For correct operation, smoke vents as well as smoke exhaust & ventilation vents require connecting to devices controlling their opening and closing. A set of such devices constitutes a system for smoke exhaust control or smoke exhaust and ventilation control. Depending on the type of devices used, it may be designed as a:

- » pneumatic smoke exhaust control system,
- » 24V electric smoke exhaust control system with ventilation function,
- » pneumatic and electric control system; the pneumatic part is responsible for smoke exhaust, while the 230V~ electric part - for ventilation.

Smoke exhaust control systems are activated as follows:

1. automatic – through a Thermo switch installed in the vent (pneumatic system), or by optical smoke sensors (electric system),
2. manual – by a release of CO2 cartridges in alarm box (pneumatic system), or by operation of RPO emergency pushbutton (electric system),
3. FAS signal – by external impulse from fire alarm system (FAS) sent to an electromagnet installed in the alarm box (pneumatic system), or directly to smoke exhaust control unit (electric system).

VENT Type	PNEUMATIC CONTROL(*)			ELECTRIC CONTROL(**)	
	PNEUMATIC ACTUATOR		MIN. CO ₂ CARTRIDGE CAPACITY – SL 950 [g]	POWER CONSUMPTION [A] BY ELECTRIC ACTUATOR FOR CLASS	
	STROKE [mm]	DIAMETER [mm]		SL 250	SL 550
DVP 120/250	350	40	24	2 x 0,8	2 x 1,3
DVP 120/300	350	40	38	2 x 1,0	2 x 1,6
DVP 150/250	350	40	38	2 x 1,0	2 x 2,0
DVP 150/300	350	40	40	2 x 1,3	2 x 2,0
DVP 160/160	400	40	38	2 x 1,0	2 x 1,6
DVP 160/250	400	40	40	2 x 1,3	2 x 2,6
DVP 160/280	400	50/40	55	2 x 1,3	2 x 2,6
DVP 160/300	400	50/40	55	2 x 1,3	2 x 2,6
DVP 180/160	400	40	38	2 x 1,6	2 x 2,0
DVP 180/180	400	40	38	2 x 1,6	2 x 2,0
DVP 180/250	400	50/40	55	2 x 1,6	2 x 2,6
DVP 180/280	400	50/40	55	2 x 1,6	2 x 2,6
DVP 180/300	400	50	55	2 x 1,6	2 x 4,0
DVP 200/200	500	40	55	2 x 1,6	2 x 2,6
DVP 200/240	500	50/40	55	2 x 1,6	2 x 4,0
DVP 200/250	500	50/40	55	2 x 2,0	2 x 4,0
DVP 200/280	500	50/40	80	2 x 2,0	2 x 4,0
DVP 200/300	500	50/40	80	2 x 2,0	2 x 4,0
DVP 220/220	500	50	80	2 x 2,0	2 x 4,0
DVP 220/240	500	50	55	2 x 2,0	2 x 6,0
DVP 220/250	500	50	80	2 x 2,0	2 x 6,0
DVP 240/240	600	50	80	2 x 2,6	2 x 6,0
DVP 240/250	600	50	80	2 x 2,6	2 x 6,0
DVP 250/250	600	50	120	2 x 4,0	2 x 6,0
DVP 250/300	600	50	120	2 x 4,0	2 x 8,0
DVP 300/300	750	63/50	150	2 x 6,0	2 x 8,0

(*) Pneumatic control available in classes: SL 250, SL 550, SL 750, SL 950 and SL 1300 at special request (applies to selected vent sizes).

(**) Selectric control available in classes: SL 750, SL 950, SL 1300, SL 1600 and SL 2000 at special request (applies to selected vent sizes). Power consumption specified in the table applies to smoke vent with multi-chamber polycarbonate glazing.

1.3. | Single-leaf smoke vents with skew base – type NG-A

1.3.1 | Technical description of standard

- » classification as per Certificate of Conformity in accordance with EN 12101-2 (CE Certificate),
- » NG-A type (squared and rectangular) smoke vents for flat and pitched roofs covered with roofing paper or PVC membrane,
- » skew base of height 300 mm or 500 mm made of galvanized steel sheet of 1.25 mm thickness
- » bottom part of the base has a circumferential flange of width 100 mm, through which the base is fitted to the roof structure,
- » upper part of base has shape enabling water runoff,
- » base standard: mcr Prolight: thermal insulation of base made of mineral wool of thickness 20 mm; heat transfer coefficient $U=1.41 \text{ W/m}^2\text{K}$, circumferential strip in the upper part of base, made of galvanized steel sheet, used for fixing flashings,
- » leaf glazing: multi-chamber polycarbonate panel, acrylic dome, solid polycarbonate dome, sandwich panel, multi-chamber polycarbonate panel and single or double-layer acrylic dome or solid polycarbonate dome, multi-chamber polycarbonate panel, envelope cover and glazing of B_{ROOF} (t1) class (details in section 4),
- » leaf opening angle $\geq 140^\circ$,
- » hinges fixing the leaf to base installed at lengthwise side of vent,
- » smoke exhaust control: pneumatic, electric 24V-,
- » ventilation control: electric 230V~.

1.3.2 | Smoke vent design

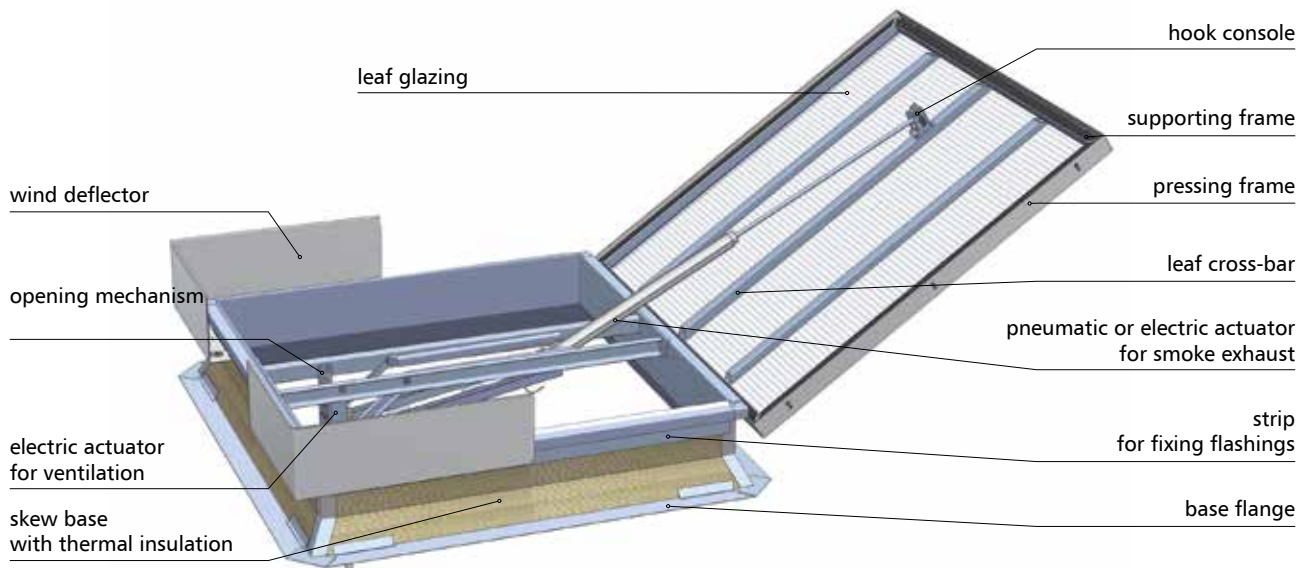

Fig.7 Design of mcr PROLIGHT NG-A smoke vent equipped with wind deflectors, with pneumatic actuator for smoke exhaust and electric actuator for ventilation

1.3.3 | Non-standard options

- » vent elements painted to any RAL color - applies to base and wind deflectors,
- » thermal insulation of base made of PIR panel of 30 mm thickness, heat transfer coefficient $U=0.68 \text{ W/m}^2\text{K}$,
- » base made of aluminium sheet of 2,00 mm thickness,
- » custom dimensions of clear opening of vent base,
- » custom base height within 300 mm ÷ 700 mm,
- » custom width of circumferential flange of base,
- » circumferential strip for fixing roof flashings made of PVC coated metal sheet,
- » base and opening mechanism in stainless steel (on request),
- » broad range of optional accessories.

1.3.4 | Technical drawings

» Smoke vent with wind deflectors, with pneumatic control for smoke exhaust and electric actuator for ventilation

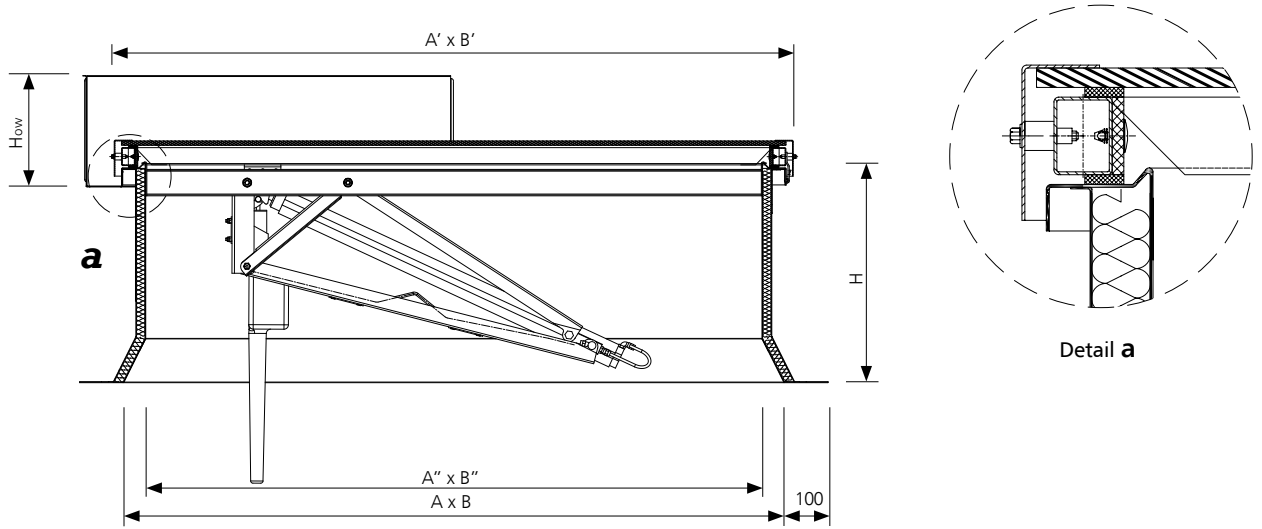

Fig.8 Section B-B of mcr PROLIGHT NG-A smoke vent in closed position, dimensions in [mm]

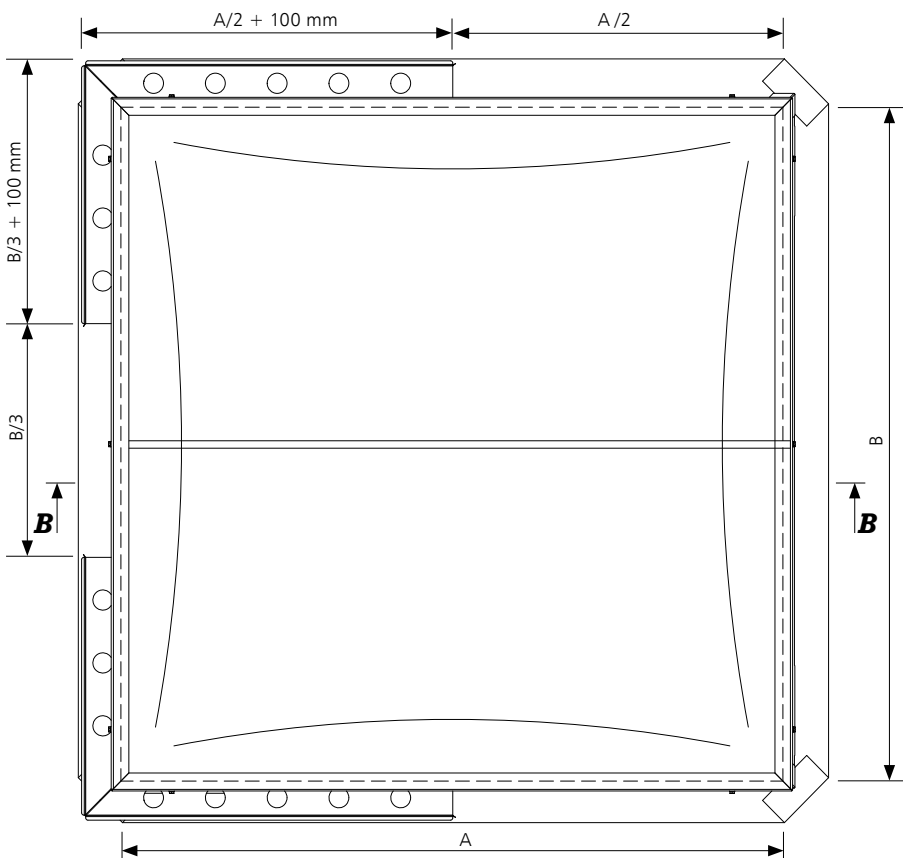

Fig.9 Top view of mcr PROLIGHT NG-A smoke vent in closed position, dimensions in [mm]

- A, B – nominal dimensions [mm], clear opening of smoke vent
- A', B' – total dimensions of smoke vent leaf $A' = A + 135$ mm, $B' = B + 35$ mm
- A'', B'' – clear dimensions of smoke vent upper opening $A'' = A - 100$ mm, $B'' = B - 100$ mm
- H – smoke vent base height [mm]
- H_{ow} – wind deflector height 230 mm \leq H_{ow} \leq 530 mm

1.3.5 | Technical details

VENT Type	NOMINAL DIMENSIONS(*)	BASE OF MIN. H=500 mm	BASE OF MIN. H=300 mm	ESTIMATED WEIGHT(**)
	A x B	ACTIVE AREA Aa [m ²]	ACTIVE AREA Aa [m ²]	
	[mm]	BASE OF MIN. H=500 mm	BASE OF MIN. H=300 mm	[kg]
NG-A 100/100	1000 x 1000	0,66	0,66	78
NG-A 100/110	1000 x 1100	0,74	0,73	81
NG-A 100/120	1000 x 1200	0,81	0,80	84
NG-A 100/130	1000 x 1300	0,89	0,87	87
NG-A 100/140	1000 x 1400	0,96	0,94	90
NG-A 100/150	1000 x 1500	1,03	1,01	96
NG-A 100/160	1000 x 1600	1,11	1,08	100
NG-A 100/170	1000 x 1700	1,18	1,15	103
NG-A 100/180	1000 x 1800	1,26	1,23	106
NG-A 100/190	1000 x 1900	1,33	1,30	110
NG-A 100/200	1000 x 2000	1,40	1,37	113
NG-A 100/210	1000 x 2100	1,48	1,44	116
NG-A 100/220	1000 x 2200	1,55	1,51	119
NG-A 100/230	1000 x 2300	1,62	1,58	122
NG-A 100/240	1000 x 2400	1,70	1,65	125
NG-A 100/250	1000 x 2500	1,77	1,72	129
NG-A 120/120	1200 x 1200	0,99	0,97	91
NG-A 120/130	1200 x 1300	1,08	1,06	94
NG-A 120/140	1200 x 1400	1,17	1,14	97
NG-A 120/150	1200 x 1500	1,26	1,23	104
NG-A 120/170	1200 x 1700	1,44	1,40	110
NG-A 120/180	1200 x 1800	1,54	1,49	114
NG-A 120/190	1200 x 1900	1,63	1,58	117
NG-A 120/200	1200 x 2000	1,72	1,66	120
NG-A 120/210	1200 x 2100	1,81	1,75	124
NG-A 120/220	1200 x 2200	1,90	1,84	127
NG-A 120/230	1200 x 2300	1,99	1,92	130
NG-A 120/240	1200 x 2400	2,08	2,01	133
NG-A 120/250	1200 x 2500	2,17	2,10	137
NG-A 125/125	1250 x 1250	1,08	1,06	94
NG-A 130/130	1300 x 1300	1,18	1,15	97
NG-A 130/140	1300 x 1400	1,28	1,25	100
NG-A 130/150	1300 x 1500	1,38	1,34	108
NG-A 130/160	1300 x 1600	1,48	1,44	111
NG-A 130/170	1300 x 1700	1,58	1,53	114
NG-A 130/180	1300 x 1800	1,68	1,62	118
NG-A 130/190	1300 x 1900	1,77	1,72	121
NG-A 130/200	1300 x 2000	1,87	1,81	124
NG-A 130/210	1300 x 2100	1,97	1,91	128
NG-A 130/220	1300 x 2200	2,07	2,00	131
NG-A 130/230	1300 x 2300	2,17	2,10	134
NG-A 130/240	1300 x 2400	2,27	2,19	138
NG-A 130/250	1300 x 2500	2,37	2,28	141
NG-A 140/140	1400 x 1400	1,39	1,35	104
NG-A 140/150	1400 x 1500	1,49	1,45	111
NG-A 140/160	1400 x 1600	1,60	1,55	115

VENT Type	NOMINAL DIMENSIONS(*)	BASE OF MIN. H=500 mm	BASE OF MIN. H=300 mm	ESTIMATED WEIGHT(**)
	A x B	ACTIVE AREA Aa [m ²]	ACTIVE AREA Aa [m ²]	
	[mm]	BASE OF MIN. H=500 mm	BASE OF MIN. H=300 mm	[kg]
NG-A 140/170	1400 x 1700	1,71	1,66	118
NG-A 140/180	1400 x 1800	1,82	1,76	122
NG-A 140/190	1400 x 1900	1,92	1,86	125
NG-A 140/200	1400 x 2000	2,03	1,96	128
NG-A 140/210	1400 x 2100	2,14	2,06	132
NG-A 140/220	1400 x 2200	2,24	2,17	135
NG-A 140/230	1400 x 2300	2,35	2,27	138
NG-A 140/240	1400 x 2400	2,46	2,37	142
NG-A 140/250	1400 x 2500	2,56	2,47	145
NG-A 150/150	1500 x 1500	1,61	1,56	120
NG-A 150/160	1500 x 1600	1,72	1,67	124
NG-A 150/170	1500 x 1700	1,84	1,78	127
NG-A 150/180	1500 x 1800	1,96	1,89	130
NG-A 150/190	1500 x 1900	2,07	2,00	134
NG-A 150/200	1500 x 2000	2,19	2,11	137
NG-A 150/210	1500 x 2100	2,30	2,22	141
NG-A 150/220	1500 x 2200	2,42	2,33	144
NG-A 150/230	1500 x 2300	2,53	2,44	148
NG-A 150/240	1500 x 2400	2,65	2,55	151
NG-A 150/250	1500 x 2500	2,76	2,66	154
NG-A 160/160	1600 x 1600	1,85	1,79	128
NG-A 160/170	1600 x 1700	1,97	1,91	131
NG-A 160/180	1600 x 1800	2,10	2,02	134
NG-A 160/190	1600 x 1900	2,22	2,14	138
NG-A 160/200	1600 x 2000	2,34	2,26	141
NG-A 160/210	1600 x 2100	2,47	2,38	145
NG-A 160/220	1600 x 2200	2,59	2,49	148
NG-A 160/230	1600 x 2300	2,71	2,61	151
NG-A 160/240	1600 x 2400	2,84	2,73	154
NG-A 160/250	1600 x 2500	2,96	2,85	158
NG-A 170/170	1700 x 1700	2,10	2,03	135
NG-A 170/180	1700 x 1800	2,24	2,16	138
NG-A 170/190	1700 x 1900	2,37	2,28	142
NG-A 170/200	1700 x 2000	2,50	2,41	145
NG-A 170/210	1700 x 2100	2,63	2,53	149
NG-A 170/220	1700 x 2200	2,76	2,66	152
NG-A 170/230	1700 x 2300	2,89	2,78	155
NG-A 170/240	1700 x 2400	3,03	2,91	159
NG-A 170/250	1700 x 2500	3,16	3,03	162
NG-A 180/180	1800 x 1800	2,38	2,29	152
NG-A 180/190	1800 x 1900	2,52	2,42	156
NG-A 180/200	1800 x 2000	2,66	2,56	159
NG-A 180/210	1800 x 2100	2,80	2,69	163
NG-A 180/220	1800 x 2200	2,94	2,82	166
NG-A 180/230	1800 x 2300	3,08	2,95	170
NG-A 180/240	1800 x 2400	3,22	3,09	173

VENT Type	NOMINAL DIMENSIONS(*)	BASE OF MIN. H=500 mm	BASE OF MIN. H=300 mm	ESTIMATED WEIGHT(**)
	A x B	ACTIVE AREA Aa [m ²]	ACTIVE AREA Aa [m ²]	
	[mm]	BASE OF MIN. H=500 mm	BASE OF MIN. H=300 mm	[kg]
NG-A 180/250	1800 x 2500	3,36	3,22	176
NG-A 180/260	1800 x 2600	3,50	3,35	180
NG-A 180/270	1800 x 2700	3,64	3,49	183
NG-A 180/280	1800 x 2800	3,78	3,62	186
NG-A 180/290	1800 x 2900	3,92	3,75	189
NG-A 180/300	1800 x 3000	4,06	3,89	193
NG-A 190/190	1900 x 1900	2,66	2,56	160
NG-A 190/200	1900 x 2000	2,81	2,70	163
NG-A 190/210	1900 x 2100	2,96	2,84	167
NG-A 190/220	1900 x 2200	3,11	2,99	170
NG-A 190/230	1900 x 2300	3,26	3,13	174
NG-A 190/240	1900 x 2400	3,40	3,27	177
NG-A 190/250	1900 x 2500	3,55	3,41	180
NG-A 190/260	1900 x 2600	3,70	3,55	184
NG-A 190/270	1900 x 2700	3,85	3,69	187
NG-A 190/280	1900 x 2800	4,00	3,83	191
NG-A 190/290	1900 x 2900	4,15	3,97	194
NG-A 190/300	1900 x 3000	4,29	4,11	197
NG-A 200/200	2000 x 2000	2,97	2,85	167
NG-A 200/210	2000 x 2100	3,12	3,00	171
NG-A 200/220	2000 x 2200	3,28	3,15	174
NG-A 200/230	2000 x 2300	3,44	3,30	178
NG-A 200/240	2000 x 2400	3,59	3,45	181
NG-A 200/250	2000 x 2500	3,75	3,59	185
NG-A 200/260	2000 x 2600	3,91	3,74	188
NG-A 200/270	2000 x 2700	4,06	3,89	191
NG-A 200/280	2000 x 2800	4,22	4,04	195
NG-A 200/290	2000 x 2900	4,38	4,19	198
NG-A 200/300	2000 x 3000	4,53	4,34	202
NG-A 210/210	2100 x 2100	3,29	3,16	175

(*) Intermediate smoke vent dimensions between the values specified in the table are possible. The size of active smoke exhaust area for those dimensions is determined through linear interpolation method.

(**) Estimated weight specified for smoke vent of base height 500 mm with wind deflectors, of standard configuration with multi-chamber polycarbonate panel glazing of 16 mm thickness, with pneumatic control.

1.3.6 | **Smoke vents control**

For correct operation, smoke vents as well as smoke exhaust & ventilation vents require connecting to devices controlling their opening and closing. A set of such devices constitutes a system for smoke exhaust control or smoke exhaust and ventilation control. Depending on the type of devices used, it may be designed as a:

- » pneumatic smoke exhaust control system,
- » 24V electric smoke exhaust control system with ventilation function,
- » pneumatic and electric control system; the pneumatic part is responsible for smoke exhaust, while the 230V~ electric part - for ventilation.

Smoke exhaust control systems are activated as follows:

1. automatic – through a thermal valve installed in the vent (pneumatic system), or by optical smoke sensors (electric system),
2. manual – by a release of CO₂ cartridges in alarm box (pneumatic system), or by operation of RPO emergency pushbutton (electric system),
3. FAS signal – by external impulse from fire alarm system (FAS) sent to an electromagnet installed in the alarm box (pneumatic system), or directly to smoke exhaust control unit (electric system).

VENT Type	PNEUMATIC CONTROL(*)			ELECTRIC CONTROL(**)	
	PNEUMATIC ACTUATOR		MIN. CO ₂ CARTRIDGE CAPACITY – SL 950 [g]	POWER CONSUMPTION [A] BY ELECTRIC ACTUATOR FOR CLASS	
	STROKE [mm]	DIAMETER [mm]		SL 250	SL 550
NG-A 100/100	550	50	24	-	-
NG-A 100/110	550	50	24	-	-
NG-A 100/120	550	50	24	-	-
NG-A 100/130	550	50	24	-	-
NG-A 100/140	550	50	24	-	-
NG-A 100/150	550	50	24	-	-
NG-A 100/160	550	50	24	-	-
NG-A 100/170	550	50	40	-	-
NG-A 100/180	550	50	40	-	-
NG-A 100/190	550	50	40	-	-
NG-A 100/200	550	50	40	-	-
NG-A 100/210	550	50	40	-	-
NG-A 100/220	550	50	40	-	-
NG-A 100/230	550	50	40	-	-
NG-A 100/240	550	50	40	-	-
NG-A 100/250	550	50	40	-	-
NG-A 120/120	550	50	24	1,6	2,6
NG-A 120/130	550	50	40	1,6	2,6
NG-A 120/140	550	50	40	1,6	2,6
NG-A 120/150	550	50	40	1,6	4,0
NG-A 120/170	550	50	40	2,0	4,0
NG-A 120/180	550	50	40	2,6	4,0
NG-A 120/190	550	50	40	2,6	6,0
NG-A 120/200	550	50	40	2,6	6,0
NG-A 120/210	550	50	40	2,6	6,0
NG-A 120/220	550	50	55	4,0	6,0
NG-A 120/230	550	50	55	4,0	6,0
NG-A 120/240	550	50	55	4,0	6,0
NG-A 120/250	550	50	55	4,0	6,0
NG-A 125/125	550	50	24	1,6	4,0

VENT Type	PNEUMATIC CONTROL(*)			ELECTRIC CONTROL(**)	
	PNEUMATIC ACTUATOR		MIN. CO ₂ CARTRIDGE CAPACITY – SL 950 [g]	POWER CONSUMPTION [A] BY ELECTRIC ACTUATOR FOR CLASS	
	STROKE [mm]	DIAMETER [mm]		SL 250	SL 550
NG-A 130/130	550	50	40	2,0	4,0
NG-A 130/140	550	50	40	2,0	4,0
NG-A 130/150	550	50	40	2,0	4,0
NG-A 130/160	550	50	40	2,6	4,0
NG-A 130/170	550	50	40	2,6	6,0
NG-A 130/180	550	50	40	2,6	6,0
NG-A 130/190	550	50	40	2,6	6,0
NG-A 130/200	550	50	40	2,6	6,0
NG-A 130/210	550	50	40	2,6	6,0
NG-A 130/220	550	50	55	4,0	6,0
NG-A 130/230	550	50	55	4,0	6,0
NG-A 130/240	550	50	55	4,0	6,0
NG-A 130/250	550	50	55	4,0	6,0
NG-A 140/140	550	50	40	2,6	4,0
NG-A 140/150	550	50	40	2,6	6,0
NG-A 140/160	550	50	40	2,6	6,0
NG-A 140/170	550	50	40	2,6	6,0
NG-A 140/180	550	50	55	4,0	6,0
NG-A 140/190	550	50	55	4,0	6,0
NG-A 140/200	550	50	55	4,0	6,0
NG-A 140/210	550	50	55	4,0	6,0
NG-A 140/220	550	50	55	4,0	6,0
NG-A 140/230	550	50	55	4,0	6,0
NG-A 140/240	550	50	55	4,0	8,0
NG-A 140/250	550	50	80	4,0	8,0
NG-A 150/150	750	50	40	2,6	6,0
NG-A 150/160	750	50	40	2,6	6,0
NG-A 150/170	750	50	55	4,0	6,0
NG-A 150/180	750	50	55	4,0	6,0
NG-A 150/190	750	50	55	4,0	8,0
NG-A 150/200	750	50	55	4,0	8,0
NG-A 150/210	750	50	55	4,0	8,0
NG-A 150/220	750	50	80	4,0	8,0
NG-A 150/230	750	50	80	4,0	8,0
NG-A 150/240	750	50	80	4,0	8,0
NG-A 150/250	750	50	80	6,0	8,0
NG-A 160/160	750	50	55	4,0	6,0
NG-A 160/170	750	50	55	4,0	8,0
NG-A 160/180	750	50	55	4,0	8,0
NG-A 160/190	750	50	55	4,0	8,0
NG-A 160/200	750	50	80	6,0	8,0
NG-A 160/210	750	50	80	6,0	8,0
NG-A 160/220	750	50	80	6,0	8,0
NG-A 160/230	750	50	80	6,0	8,0
NG-A 160/240	750	50	80	6,0	8,0
NG-A 160/250	750	50	80	6,0	8,0
NG-A 170/170	750	50	55	6,0	-
NG-A 170/180	750	50	80	6,0	-
NG-A 170/190	750	50	80	6,0	-

VENT Type	PNEUMATIC CONTROL(*)			ELECTRIC CONTROL(**)	
	PNEUMATIC ACTUATOR		MIN. CO ₂ CARTRIDGE CAPACITY – SL 950 [g]	POWER CONSUMPTION [A] BY ELECTRIC ACTUATOR FOR CLASS	
	STROKE [mm]	DIAMETER [mm]		SL 250	SL 550
NG-A 170/200	750	50	80	6,0	-
NG-A 170/210	750	50	80	6,0	-
NG-A 170/220	750	50	80	6,0	-
NG-A 170/230	750	50	80	6,0	-
NG-A 170/240	750	50	80	6,0	-
NG-A 170/250	750	50	80	6,0	-
NG-A 180/180	1050	63	80	6,0	-
NG-A 180/190	1050	63	120	6,0	-
NG-A 180/200	1050	63	120	8,0	-
NG-A 180/210	1050	63	120	8,0	-
NG-A 180/220	1050	63	120	8,0	-
NG-A 180/230	1050	63	120	8,0	-
NG-A 180/240	1050	63	120	8,0	-
NG-A 180/250	1050	63	120	8,0	-
NG-A 180/260	1050	63	120	8,0	-
NG-A 180/270	1050	63	120	-	-
NG-A 180/280	1050	63	120	-	-
NG-A 180/290	1050	63	120	-	-
NG-A 180/300	1050	63	120	-	-
NG-A 190/190	1050	63	120	6,0	-
NG-A 190/200	1050	63	120	6,0	-
NG-A 190/210	1050	63	120	6,0	-
NG-A 190/220	1050	63	120	8,0	-
NG-A 190/230	1050	63	120	8,0	-
NG-A 190/240	1050	63	120	8,0	-
NG-A 190/250	1050	63	120	8,0	-
NG-A 190/260	1050	63	120	8,0	-
NG-A 190/270	1050	63	120	-	-
NG-A 190/280	1050	63	120	-	-
NG-A 190/290	1050	63	120	-	-
NG-A 190/300	1050	63	120	-	-
NG-A 200/200	1050	63	120	8,0	-
NG-A 200/210	1050	63	120	8,0	-
NG-A 200/220	1050	63	120	8,0	-
NG-A 200/230	1050	63	120	8,0	-
NG-A 200/240	1050	63	120	-	-
NG-A 200/250	1050	63	120	-	-
NG-A 200/260	1050	63	120	-	-
NG-A 200/270	1050	63	120	-	-
NG-A 200/280	1050	63	120	-	-
NG-A 200/290	1050	63	120	-	-
NG-A 200/300	1050	63	120***	-	-
NG-A 210/210	1050	63	120	8,0	-
NG-A 220/220	1050	63	120	-	-

(*) Pneumatic control available in classes: SL 250, SL 550, SL 750, SL 950, SL 1300, SL 1600 and SL 2000 at special request (applies to selected vent sizes).

(**) Electric control available in classes: SL 750, SL 950, SL 1300 and SL 1600 at special request (applies to selected vent sizes). Power consumption specified in the table applies to smoke vent with multi-chamber polycarbonate glazing.

(***) SL 900

1.4. | Double-leaf smoke vents with skew base - type DVPS

1.4.1 | Technical description of standard

- » classification as per Certificate of Conformity in accordance with EN 12101-2 (CE Certificate),
- » DVP type smoke vents (double-leaf) for flat and pitched roofs covered with roofing paper or PVC membrane,
- » skew base of height 300 mm or 500 mm made of galvanized steel sheet of 1.25 mm thickness
- » bottom part of the base has a circumferential flange of width 100 mm, through which the base is fitted to the roof structure,
- » upper part of base has shape enabling water runoff,
- » thermal insulation of base made of mineral wool of thickness 20 mm; heat transfer coefficient $U=1.41 \text{ W/m}^2\text{K}$
- » circumferential strip of galvanized steel sheet for fixing roof flashing,
- » wind deflectors made of aluminum or galvanized steel sheet,
- » leaf glazing: multi-chamber polycarbonate panel, sandwich panel, multi-chamber polycarbonate panel with aluminum envelope cover and glazing with B_{ROOF} (t1) classification (details in section 4),
- » leaf opening angle $\geq 90^\circ$,
- » hinges fixing the leaf to base installed at lengthwise side of vent,
- » smoke exhaust control: pneumatic, electric 24V-,
- » ventilation control: electric 230V~.

1.4.2 | Smoke vent design

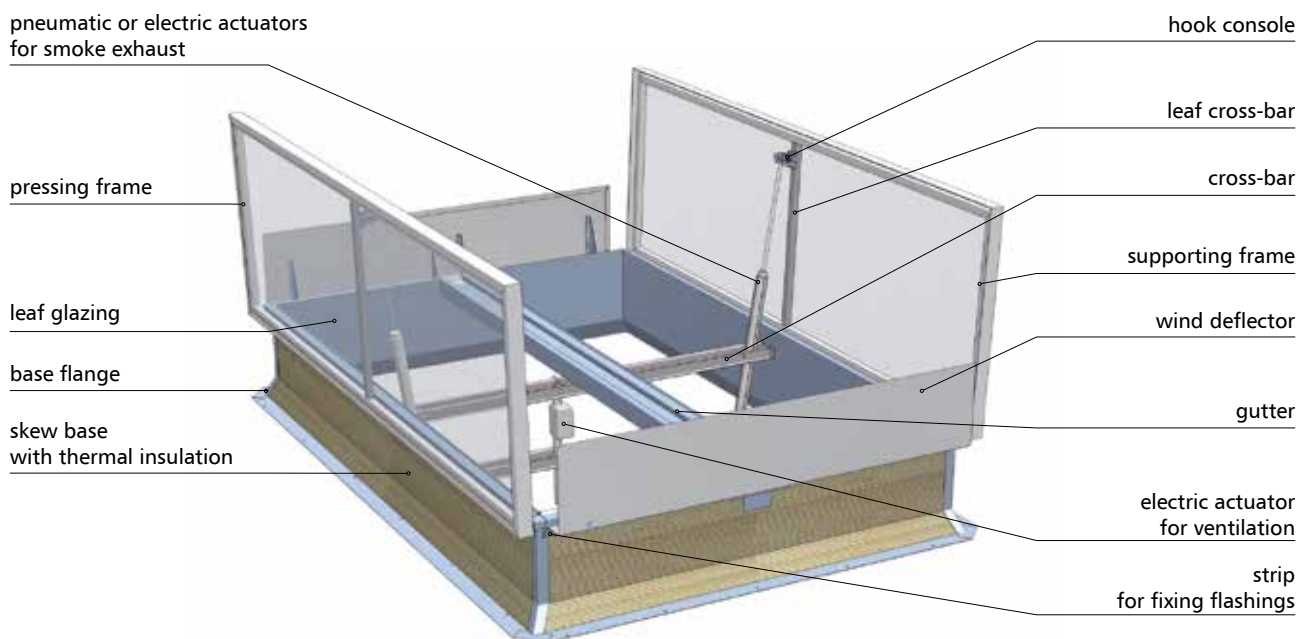

Fig.10 Design of mcr PROLIGHT DVPS smoke vent equipped with wind deflectors, with pneumatic actuators for smoke exhaust and electric actuator for ventilation

1.4.3 | Non-standard options

- » vent elements painting to any RAL color - applies to pressing frame, wind deflectors and base - powder coating up to 1800x3000 [mm] dimensions,
- » thermal insulation of base made of PIR panel of 30 mm thickness, heat transfer coefficient $U=0.68 \text{ W/m}^2\text{K}$,
- » base made of aluminium sheet of 2,00 mm thickness,
- » custom dimensions of clear opening of vent base,
- » custom base height within 300 mm ÷ 700 mm,
- » custom width of circumferential flange of base,
- » circumferential strip for fixing roof flashings made of PVC coated metal sheet,
- » base and cross-bar in stainless steel,
- » broad range of optional accessories.

1.4.4 | Technical drawings

» Smoke vent with wind deflectors, with pneumatic control for smoke exhaust and electric actuator for ventilation

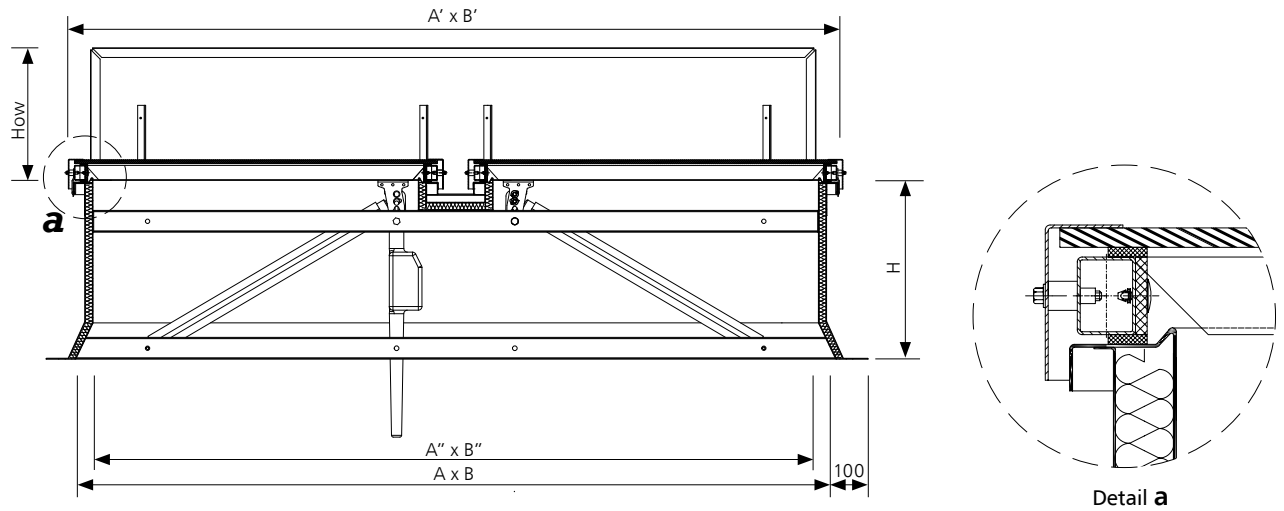

Fig.11 Section B-B of mcr PROLIGHT DVPS smoke vent in closed position, dimensions in [mm]

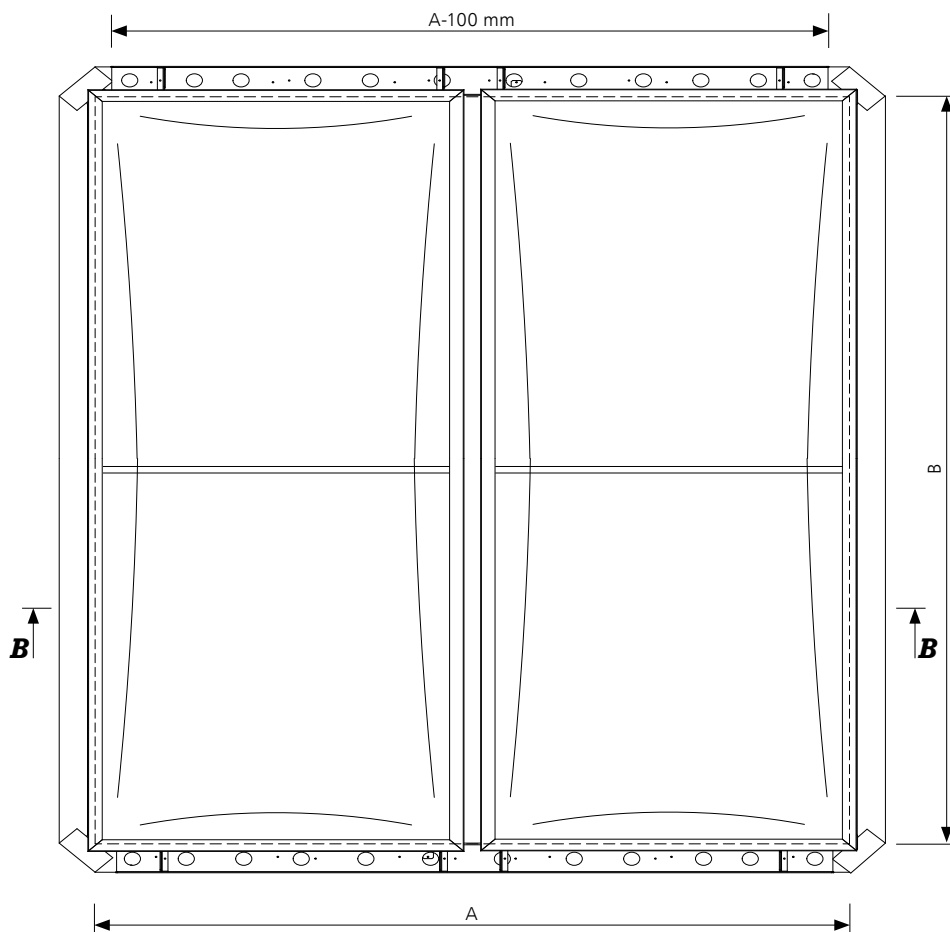

Fig.12 Top view of mcr PROLIGHT DVPS smoke vent in closed position, dimensions in [mm]

- A, B – nominal dimensions [mm], clear opening of smoke vent
- A', B' – total dimensions of smoke vent leaf $A' = A + 35$ mm, $B' = B + 35$ mm
- A'', B'' – clear dimensions of smoke vent upper opening $A'' = A - 100$ mm, $B'' = B - 100$ mm
- H – smoke vent base height [mm]
- How – wind deflector height $100 \text{ mm} \leq \text{How} \leq 390 \text{ mm}$

1.4.5 | Technical details

VENT Type	NOMINAL DIMENSIONS(*)	BASE OF MIN. H=500 mm	BASE OF MIN. H=300 mm	ESTIMATED WEIGHT(**)
	A x B	ACTIVE AREA Aa [m ²]	ACTIVE AREA Aa [m ²]	
	[mm]	BASE OF MIN. H=500 mm	BASE OF MIN. H=300 mm	[kg]
DVPS 120/250	1200 x 2500	1,80	1,83	160
DVPS 120/300	1200 x 3000	2,20	2,20	183
DVPS 150/250	1500 x 2500	2,36	2,36	172
DVPS 150/300	1500 x 3000	2,93	2,84	195
DVPS 160/160	1600 x 1600	1,54	1,56	138
DVPS 160/250	1600 x 2500	2,56	2,52	178
DVPS 160/280	1600 x 2800	2,91	2,87	192
DVPS 160/300	1600 x 3000	3,12	3,07	201
DVPS 180/160	1800 x 1600	1,76	1,76	147
DVPS 180/180	1800 x 1800	2,04	2,01	156
DVPS 180/250	1800 x 2500	2,97	2,88	189
DVPS 180/280	1800 x 2800	3,33	3,23	203
DVPS 180/300	1800 x 3000	3,62	3,51	212
DVPS 200/200	2000 x 2000	2,60	2,52	173
DVPS 200/240	2000 x 2400	3,17	3,07	192
DVPS 200/250	2000 x 2500	3,35	3,25	197
DVPS 200/280	2000 x 2800	3,75	3,64	211
DVPS 200/300	2000 x 3000	4,08	3,90	221
DVPS 220/220	2200 x 2200	3,19	3,15	194
DVPS 220/240	2200 x 2400	3,54	3,43	204
DVPS 220/250	2200 x 2500	3,69	3,58	208
DVPS 240/240	2400 x 2400	3,92	3,74	212
DVPS 240/250	2400 x 2500	4,08	3,96	216
DVPS 250/250	2500 x 2500	4,31	4,13	223
DVPS 250/300	2500 x 3000	5,25	5,03	247
DVPS 300/300	3000 x 3000	6,39	6,03	272

(*) Intermediate smoke vent dimensions between the values specified in the table are possible. The size of active smoke exhaust area for those dimensions is determined through linear interpolation method.

(**) Estimated weight specified for smoke vent of base height 500 mm with wind deflectors, of standard configuration with multi-chamber polycarbonate panel glazing of 16 mm thickness, with pneumatic control.

1.4.6 | **Smoke vents control**

For correct operation, smoke vents as well as smoke exhaust & ventilation vents require connecting to devices controlling their opening and closing. A set of such devices constitutes a system for smoke exhaust control or smoke exhaust and ventilation control. Depending on the type of devices used, it may be designed as a:

- » pneumatic smoke exhaust control system,
- » 24V electric smoke exhaust control system with ventilation function,
- » pneumatic and electric control system; the pneumatic part is responsible for smoke exhaust, while the 230V~ electric part - for ventilation.

Smoke exhaust control systems are activated as follows:

1. automatic – through a thermo switch installed in the vent (pneumatic system), or by optical smoke sensors (electric system),
2. manual – by a release of CO2 cartridges in alarm box (pneumatic system), or by operation of RPO emergency pushbutton (electric system),
3. FAS signal – by external impulse from fire alarm system (FAS) sent to an electromagnet installed in the alarm box (pneumatic system), or directly to smoke exhaust control unit (electric system).



VENT Type	PNEUMATIC CONTROL(*)			ELECTRIC CONTROL(**)	
	PNEUMATIC ACTUATOR		MIN. CO ₂ CARTRIDGE CAPACITY – SL 950 [g]	POWER CONSUMPTION [A] BY ELECTRIC ACTUATOR FOR CLASS	
	STROKE [mm]	DIAMETER [mm]		SL 250	SL 550
DVPS 120/250	350	40	24	2 x 0,8	2 x 1,3
DVPS 120/300	350	40	38	2 x 1,0	2 x 1,6
DVPS 150/250	350	40	38	2 x 1,0	2 x 2,0
DVPS 150/300	350	40	40	2 x 1,3	2 x 2,6
DVPS 160/160	350	40	25	2 x 0,8	2 x 1,3
DVPS 160/250	350	40	38	2 x 1,0	2 x 2,0
DVPS 160/280	350	40	38	2 x 1,0	2 x 2,0
DVPS 160/300	350	40	40	2 x 1,3	2 x 2,0
DVPS 180/160	400	40	38	2 x 1,0	2 x 2,0
DVPS 180/180	400	40	38	2 x 1,0	2 x 2,0
DVPS 180/250	400	50/40	55	2 x 1,3	2 x 2,6
DVPS 180/280	400	50/40	55	2 x 1,3	2 x 2,6
DVPS 180/300	400	50	55	2 x 1,6	2 x 2,6
DVPS 200/200	500	40	55	2 x 1,6	2 x 2,6
DVPS 200/240	500	50/40	55	2 x 1,6	2 x 4,0
DVPS 200/250	500	50/40	55	2 x 2,0	2 x 4,0
DVPS 200/280	500	50/40	80	2 x 2,0	2 x 4,0
DVPS 200/300	500	50/40	80	2 x 2,0	2 x 4,0
DVPS 220/220	500	50	80	2 x 2,0	2 x 4,0
DVPS 220/240	500	50	55	2 x 2,0	2 x 6,0
DVPS 220/250	500	50	80	2 x 2,0	2 x 6,0
DVPS 240/240	600	50	80	2 x 2,6	2 x 6,0
DVPS 240/250	600	50	80	2 x 2,6	2 x 6,0
DVPS 250/250	600	50	120	2 x 2,6	2 x 6,0
DVPS 250/300	600	50	120	2 x 2,6	2 x 6,0
DVPS 300/300	750	63/50	150	2 x 6,0	2 x 8,0

(*) Pneumatic control available in classes: SL 250, SL 550, SL 750 and SL 1300 at special request (applies to selected vent sizes).

(**) Electric control available in classes: SL 750, SL 950, SL 1300, SL 1600 and SL 2000 at special request (applies to selected vent sizes). Power consumption specified in the table applies to smoke vent with multi-chamber polycarbonate glazing.

2. | Fixed skylights, roof hatches, ventilation vents

The equipment series that includes mcr PROLIGHT fixed skylights, roof hatches and ventilation vents complements MERCOR natural smoke exhaust selection. Depending on the device chosen, they may serve the purpose of natural lighting, ventilating or increasing roof accessibility..

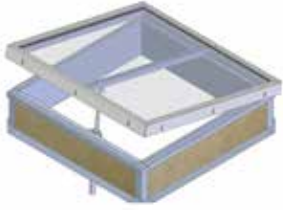
		Fixed skylights (non-openable skylights)	Roof hatches (openable skylights)	Ventilation vents (openable skylights)
Parameters				
Type	mcr PROLIGHT	C, E, NG-A	C, E, NG-A	C, E, NG-A
Product classification	CE Declaration of Conformity (as per EN 1873) (*****)	<ul style="list-style-type: none"> » Fire performance of available glazing: <ul style="list-style-type: none"> - B_{ROOF}(t1) - B-s1-d0 - B-s2-d0 - E / NPD, » Fire performance of weakest element: <ul style="list-style-type: none"> - E / NPD » Resistance to effect of external fire: <ul style="list-style-type: none"> - B_{ROOF}(t1) - F_{ROOF} » Impact resistance of skylights with multi-chamber polycarbonate: <ul style="list-style-type: none"> - SB1200 » Heat transfer coefficient for entire device $1,1 \text{ W/m}^2\text{K} \leq U \leq 3,8 \text{ W/m}^2\text{K}$ (*), dependent on: <ul style="list-style-type: none"> - type of glazing (see details in section 4) - type of device - dimensions of device - thermal insulation thickness - base type and height » Direct acoustic resistance: <ul style="list-style-type: none"> - R_w = 18÷22 dB dB for multi-chamber polycarbonates - R_w = 20 dB for double-layer domes - R_w = 22 dB for double-layer domes 		
Control	pneumatic (ventilation)	-	-	•
	electric ~230V (ventilation)	-	-	•
	mechanic (gas springs)	-	•	-
Glazing	multi-chamber polycarbonate panel	•	•	•
	acrylic dome(****)	•	•	•
	solid polycarbonate dome(****)	•	•	•
	ALU sandwich panel(**), (****)	-	•	•
	classification B _{ROOF} (t1)(***)	•	•	•
	multi-chamber polycarbonate panel and envelope cover	-	•	•
	multi-chamber polycarbonate panel and single or double-layer acrylic dome or solid polycarbonate dome(****)	•	•	•

(*) U heat transfer coefficient (thermal transmittance) available at client's request

(**) ALU sandwich panel (aluminum-thermal insulation-aluminum)

(***) B_{ROOF}(t1) glazing (multi-chamber polycarbonate of thickness ≥ 10 mm and polyester panel)

(****) Selected sizes

(*****) Only for units with translucent glazing

2.1. | Fixed skylights with straight base – type C, E

2.1.1 | Technical description of standard

- » classification in accordance with EN 1873 (ref. to units with translucent glazing),
- » C type (squared) and type E (rectangular) fixed skylights for flat and pitched roofs covered with roofing paper or PVC membrane,
- » dimensional range of fixed skylights:
 - C type fixed skylights (squared): 50x50 cm ÷ 200x200 cm
 - E type fixed skylights (rectangular): 50x50 cm ÷ 195x300 cm
- » straight base of height 300 mm or 500 mm made of galvanized steel sheet of 1.25 mm thickness
- » bottom part of the base has a circumferential flange of width 100 mm, through which the base is fitted to the roof structure,
- » upper part of base has shape enabling water runoff,
- » thermal insulation of base made of mineral wool of thickness 20 mm; heat transfer coefficient $U=1.41 \text{ W/m}^2\text{K}$
- » circumferential strip in the upper part of base, made of galvanized steel sheet, used for fixing roof work,
- » leaf glazing: multi-chamber polycarbonate panel, acrylic dome, solid polycarbonate dome, multi-chamber polycarbonate panel and single or double-layer acrylic dome or solid polycarbonate dome, glazing of B_{ROOF} (t1) classification (see details in section 4).

2.1.2 | Fixed skylight design

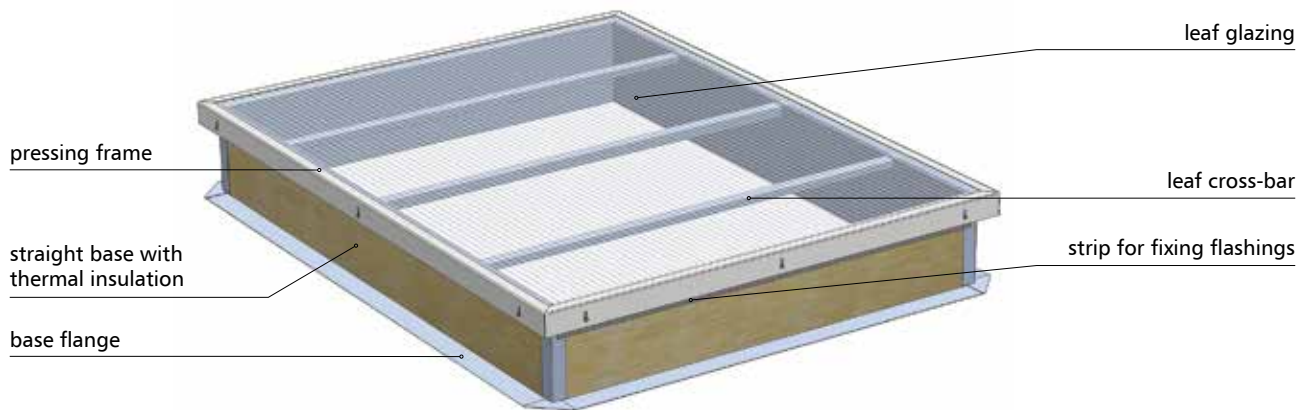

Fig.13 mcr PROLIGHT E fixed skylight design

2.1.3 | Non-standard options

- » skylight elements painted to any RAL color,
- » thermal insulation of base made of PIR panel of 30 mm thickness, heat transfer coefficient $U=0.68 \text{ W/m}^2\text{K}$,
- » custom base height 160 mm ÷ 750 mm,
- » base made of aluminium sheet of 2,00 mm thickness,
- » installation of additional protective elements in the form of anti-burglar grid or safety net,
- » available in configuration with soft body impact resistance up to 1200 J,
- » for roofs with roof membrane, optional PVC coated sheet strip for easier installation,
- » circumferential strip for fixing roof flashings made of PVC coated metal sheet.

2.1.4 | Technical drawings

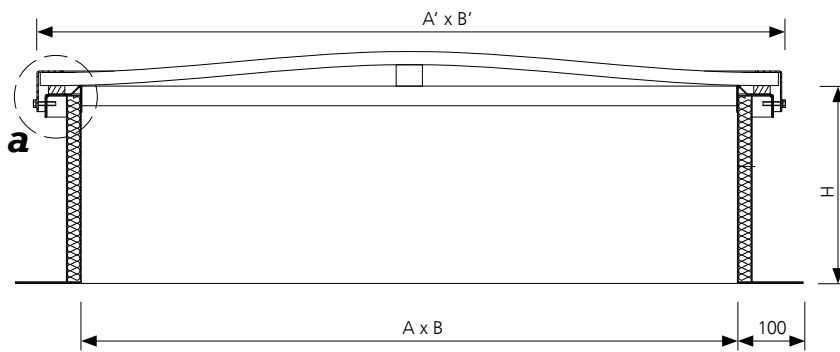
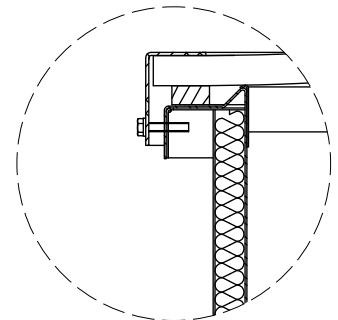

Fig.14 Section **B-B** of mcr PROLIGHT C or E fixed skylight, dimensions in [mm]



Detail **a**

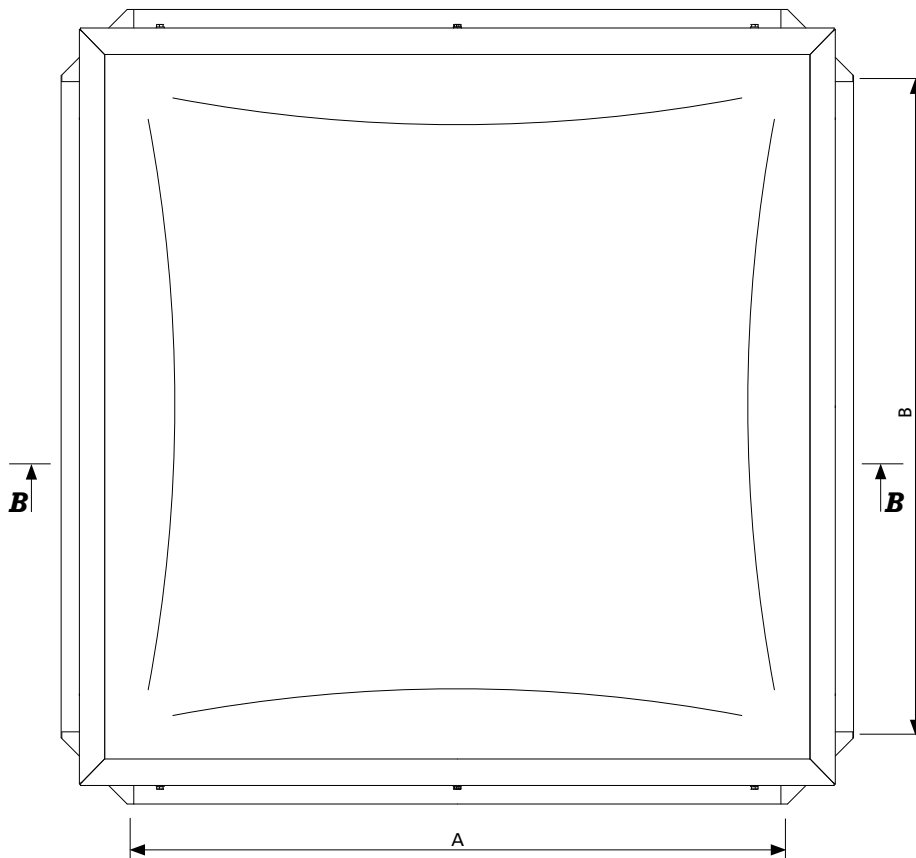

Fig.15 Top view of mcr PROLIGHT C or E fixed skylight, dimensions in [mm]

A, B – nominal dimensions [mm] of fixed skylight
 A', B' – total dimensions of fixed skylight leaf $A'=A+135$ mm, $B'=B+135$ mm
 H – fixed skylight base height [mm]

2.1.5 | Technical details

SKYLIGHT Type	NOMINAL DIMENSIONS(*)	ESTIMATED WEIGHT(**)
	A x B [mm]	[kg]
C 80	800 x 800	49
C 90	900 x 900	55
C 100	1000 x 1000	61
C 110	1100 x 1100	67
C 115	1150 x 1150	70
C 120	1200 x 1200	73
C 125	1250 x 1250	76
C 130	1300 x 1300	79
C 135	1350 x 1350	82
C 140	1400 x 1400	85
C 150	1500 x 1500	97
C 155	1550 x 1550	100
C 160	1600 x 1600	104
C 170	1700 x 1700	110
C 180	1800 x 1800	117
C 190	1900 x 1900	124
C 195	1950 x 1950	127
C 200	2000 x 2000	131
E 100/120	1000 x 1200	67
E 100/130	1000 x 1300	70
E 100/140	1000 x 1400	73
E 100/150	1000 x 1500	80
E 100/160	1000 x 1600	83
E 100/180	1000 x 1800	89
E 100/190	1000 x 1900	92
E 100/200	1000 x 2000	95
E 100/210	1000 x 2100	98
E 100/220	1000 x 2200	101
E 100/230	1000 x 2300	104
E 100/240	1000 x 2400	107
E 100/250	1000 x 2500	110
E 110/200	1100 x 2000	99
E 115/200	1150 x 2000	101
E 120/140	1200 x 1400	79
E 120/150	1200 x 1500	87
E 120/170	1200 x 1700	93
E 140/150	1400 x 1500	94
E 140/180	1400 x 1800	103
E 140/200	1400 x 2000	141
E 140/250	1400 x 2500	125
E 150/160	1500 x 1600	100
E 150/180	1500 x 1800	106
E 150/200	1500 x 2000	113
E 150/210	1500 x 2100	116
E 150/240	1500 x 2400	126
E 150/250	1500 x 2500	129

SKYLIGHT Type	NOMINAL DIMENSIONS(*)	ESTIMATED WEIGHT(**)
	A x B [mm]	[kg]
E 160/180	1600 x 1800	110
E 160/190	1600 x 1900	113
E 160/200	1600 x 2000	117
E 160/220	1600 x 2200	123
E 160/230	1600 x 2300	126
E 160/240	1600 x 2400	129
E 180/200	1800 x 2000	124
E 180/220	1800 x 2200	130
E 180/240	1800 x 2400	137
E 180/250	1800 x 2500	140
E 190/200	1900 x 2000	128
E 195/300	1950 x 3000	148

(*) Intermediate fixed skylight dimensions between the values specified in the table are possible.

(**) Estimated weight specified for fixed skylight of base height 500 mm, of standard configuration with multi-chamber polycarbonate panel glazing of 16 mm thickness.

2.2. | Fixed skylights with skew base – type NG-A

2.2.1 | Technical description of standard

- » classification in accordance with EN 1873 (ref. to units with translucent glazing),
- » NG-A type fixed skylights (squared and rectangular) smoke vents for flat and pitched roofs covered with roofing paper or PVC membrane,
- » dimensional range of fixed skylights 60x60 cm ÷ 200x300 cm / 210x210 cm
- » skew base of height 300 mm or 500 mm made of galvanized steel sheet of 1.25 mm thickness
- » bottom part of the base has a circumferential flange of width 100 mm, through which the base is fitted to the roof structure,
- » upper part of base has shape enabling water runoff,
- » thermal insulation of base made of mineral wool of thickness 20 mm; heat transfer coefficient $U=1.41 \text{ W/m}^2\text{K}$
- » circumferential strip in the upper part of base, made of galvanized steel sheet, used for fixing roof work,
- » leaf glazing: multi-chamber polycarbonate panel, acrylic dome, solid polycarbonate dome, multi-chamber polycarbonate panel and single or double-layer acrylic dome or solid polycarbonate dome, glazing of B_{ROOF} (t1) classification (see details in section 4).

2.2.2 | Fixed skylight design



Fig.16 mcr PROLIGHT NG-A fixed skylight design

2.2.3 | Non-standard options

- » skylight elements painted to any RAL color,
- » thermal insulation of base made of PIR panel of 30 mm thickness, heat transfer coefficient $U=0.68 \text{ W/m}^2\text{K}$,
- » custom base height 160 mm ÷ 750 mm,
- » base made of aluminium sheet of 2,00 mm thickness,
- » installation of additional protective elements in the form of anti-burglar grid or safety net,
- » available in configuration with soft body impact resistance up to 1200 J,
- » for roofs with roof membrane, optional PVC coated sheet strip for easier installation,
- » circumferential strip for fixing roof flashings made of PVC coated metal sheet.

2.2.4 | Technical drawings

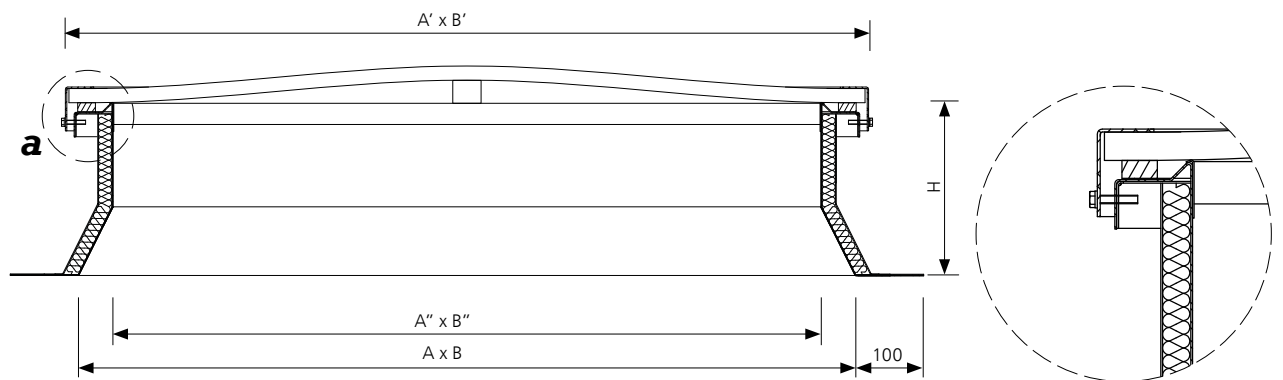

Fig.17 Section B-B of mcr PROLIGHT NG-A fixed skylight, dimensions in [mm]

Detail a

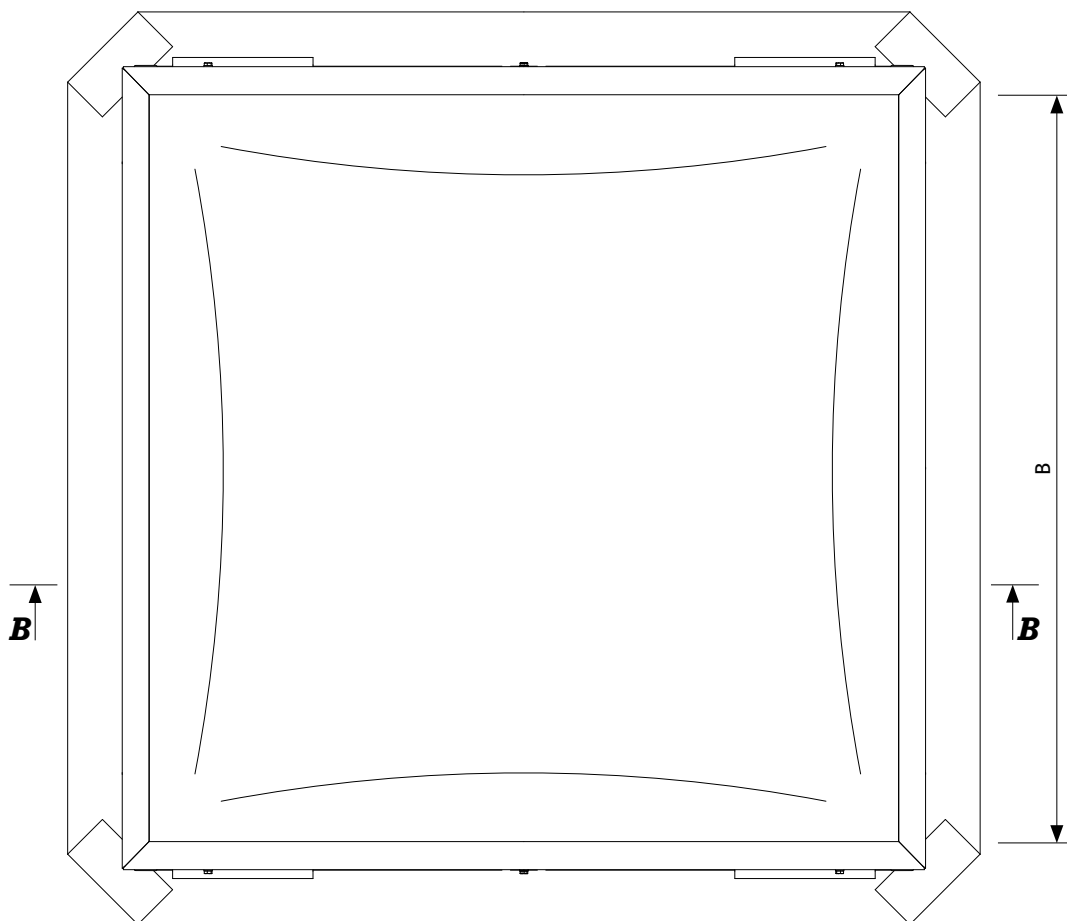

Fig.18 Top view of mcr PROLIGHT NG-A fixed skylight, dimensions in [mm]

- A, B – nominal dimensions [mm] of fixed skylight
- A', B' – total dimensions of fixed skylight leaf $A' = A + 135$ mm, $B' = B + 135$ mm
- A'', B'' – clear dimensions of fixed skylight upper opening [mm], $A'' = A - 100$ mm, $B'' = B - 100$ mm
- H – fixed skylight base height [mm]

2.2.5 | **Technical details**

SKYLIGHT Type	NOMINAL DIMENSIONS(*)	ESTIMATED WEIGHT(**)
	A x B [mm]	[kg]
NG-A 100/100	1000 x 1000	63
NG-A 100/110	1000 x 1100	66
NG-A 100/120	1000 x 1200	69
NG-A 100/130	1000 x 1300	72
NG-A 100/140	1000 x 1400	75
NG-A 100/150	1000 x 1500	81
NG-A 100/160	1000 x 1600	85
NG-A 100/170	1000 x 1700	88
NG-A 100/180	1000 x 1800	91
NG-A 100/190	1000 x 1900	95
NG-A 100/200	1000 x 2000	98
NG-A 100/210	1000 x 2100	101
NG-A 100/220	1000 x 2200	104
NG-A 100/230	1000 x 2300	107
NG-A 100/240	1000 x 2400	110
NG-A 100/250	1000 x 2500	114
NG-A 120/120	1200 x 1200	76
NG-A 120/130	1200 x 1300	79
NG-A 120/140	1200 x 1400	82
NG-A 120/150	1200 x 1500	89
NG-A 120/170	1200 x 1700	95
NG-A 120/180	1200 x 1800	99
NG-A 120/190	1200 x 1900	102
NG-A 120/200	1200 x 2000	105
NG-A 120/210	1200 x 2100	109
NG-A 120/220	1200 x 2200	112
NG-A 120/230	1200 x 2300	115
NG-A 120/240	1200 x 2400	118
NG-A 120/250	1200 x 2500	122
NG-A 125/125	1250 x 1250	79
NG-A 130/130	1300 x 1300	82
NG-A 130/140	1300 x 1400	85
NG-A 130/150	1300 x 1500	93
NG-A 130/160	1300 x 1600	96
NG-A 130/170	1300 x 1700	99
NG-A 130/180	1300 x 1800	103
NG-A 130/190	1300 x 1900	106
NG-A 130/200	1300 x 2000	109
NG-A 130/210	1300 x 2100	113
NG-A 130/220	1300 x 2200	116
NG-A 130/230	1300 x 2300	119
NG-A 130/240	1300 x 2400	123
NG-A 130/250	1300 x 2500	126
NG-A 140/140	1400 x 1400	89
NG-A 140/150	1400 x 1500	96
NG-A 140/160	1400 x 1600	100
NG-A 140/170	1400 x 1700	103
NG-A 140/180	1400 x 1800	107
NG-A 140/190	1400 x 1900	110
NG-A 140/200	1400 x 2000	113

SKYLIGHT Type	NOMINAL DIMENSIONS(*)	ESTIMATED WEIGHT(**)
	A x B [mm]	[kg]
NG-A 140/210	1400 x 2100	117
NG-A 140/220	1400 x 2200	120
NG-A 140/230	1400 x 2300	123
NG-A 140/240	1400 x 2400	127
NG-A 140/250	1400 x 2500	130
NG-A 150/150	1500 x 1500	100
NG-A 150/160	1500 x 1600	104
NG-A 150/170	1500 x 1700	107
NG-A 150/180	1500 x 1800	110
NG-A 150/190	1500 x 1900	114
NG-A 150/200	1500 x 2000	117
NG-A 150/210	1500 x 2100	121
NG-A 150/220	1500 x 2200	124
NG-A 150/230	1500 x 2300	128
NG-A 150/240	1500 x 2400	131
NG-A 150/250	1500 x 2500	134
NG-A 160/160	1600 x 1600	108
NG-A 160/170	1600 x 1700	111
NG-A 160/180	1600 x 1800	114
NG-A 160/190	1600 x 1900	118
NG-A 160/200	1600 x 2000	121
NG-A 160/210	1600 x 2100	125
NG-A 160/220	1600 x 2200	128
NG-A 160/230	1600 x 2300	131
NG-A 160/240	1600 x 2400	134
NG-A 160/250	1600 x 2500	138
NG-A 170/170	1700 x 1700	115
NG-A 170/180	1700 x 1800	118
NG-A 170/190	1700 x 1900	122
NG-A 170/200	1700 x 2000	125
NG-A 170/210	1700 x 2100	129
NG-A 170/220	1700 x 2200	132
NG-A 170/230	1700 x 2300	135
NG-A 170/240	1700 x 2400	139
NG-A 170/250	1700 x 2500	142
NG-A 180/180	1800 x 1800	122
NG-A 180/190	1800 x 1900	126
NG-A 180/200	1800 x 2000	129
NG-A 180/210	1800 x 2100	133
NG-A 180/220	1800 x 2200	136
NG-A 180/230	1800 x 2300	140
NG-A 180/240	1800 x 2400	143
NG-A 180/250	1800 x 2500	146
NG-A 180/260	1800 x 2600	150
NG-A 180/270	1800 x 2700	153
NG-A 180/280	1800 x 2800	156
NG-A 180/290	1800 x 2900	159
NG-A 180/300	1800 x 3000	163
NG-A 190/190	1900 x 1900	130
NG-A 190/200	1900 x 2000	133

SKYLIGHT Type	NOMINAL DIMENSIONS(*)	ESTIMATED WEIGHT(**)
	A x B [mm]	[kg]
NG-A 190/210	1900 x 2100	137
NG-A 190/220	1900 x 2200	140
NG-A 190/230	1900 x 2300	144
NG-A 190/240	1900 x 2400	147
NG-A 190/250	1900 x 2500	150
NG-A 190/260	1900 x 2600	154
NG-A 190/270	1900 x 2700	157
NG-A 190/280	1900 x 2800	161
NG-A 190/290	1900 x 2900	164
NG-A 190/300	1900 x 3000	167
NG-A 200/200	2000 x 2000	137
NG-A 200/210	2000 x 2100	141
NG-A 200/220	2000 x 2200	144
NG-A 200/230	2000 x 2300	148
NG-A 200/240	2000 x 2400	151
NG-A 200/250	2000 x 2500	155
NG-A 200/260	2000 x 2600	158
NG-A 200/270	2000 x 2700	161
NG-A 200/280	2000 x 2800	165
NG-A 200/290	2000 x 2900	168
NG-A 200/300	2000 x 3000	172
NG-A 210/210	2100 x 2100	145

(*) Intermediate fixed skylight dimensions between the values specified in the table are possible.

(**) Estimated weight specified for fixed skylight of base height 500 mm, of standard configuration with multi-chamber polycarbonate panel glazing of 16 mm thickness.

2.3. | Roof hatches with straight – type C, E

2.3.1 | Technical description of standard

- » classification in accordance with EN 1873 (ref. to units with translucent glazing),
- » C type roof hatches (squared) and E type (rectangular) for flat and pitched roofs covered with roofing paper or PVC membrane,
- » dimensional range for roof hatches:
 - C type roof hatches (squared): 60x60 cm ÷ 140x140 cm,
 - E type roof hatches (rectangular): 80x90 cm ÷ 140x150 cm,
- » straight base of height 300 mm or 500 mm made of galvanized steel sheet of 1.25 mm thickness
- » bottom part of base has a circumferential flange of width 100 mm, through which the base is fitted to the roof structure,
- » upper part of base profiled to allow water run-off,
- » thermal insulation of base made of mineral wool of thickness 20 mm; heat transfer coefficient $U=1.41 \text{ W/m}^2\text{K}$,
- » galvanized steel sheet circumferential strip in upper part of base allows fixing of roof flashing,
- » hatch equipped in two gas springs for easy opening to 90° open position,
- » leaf glazing: multi-chamber polycarbonate panel, acrylic dome, solid polycarbonate dome, multi-chamber polycarbonate panel and single or double-layer acrylic dome or solid polycarbonate dome, glazing of B_{ROOF} (t1) classification (see details in section 4),
- » internal handle with keylock.

2.3.2 | Roof hatch design

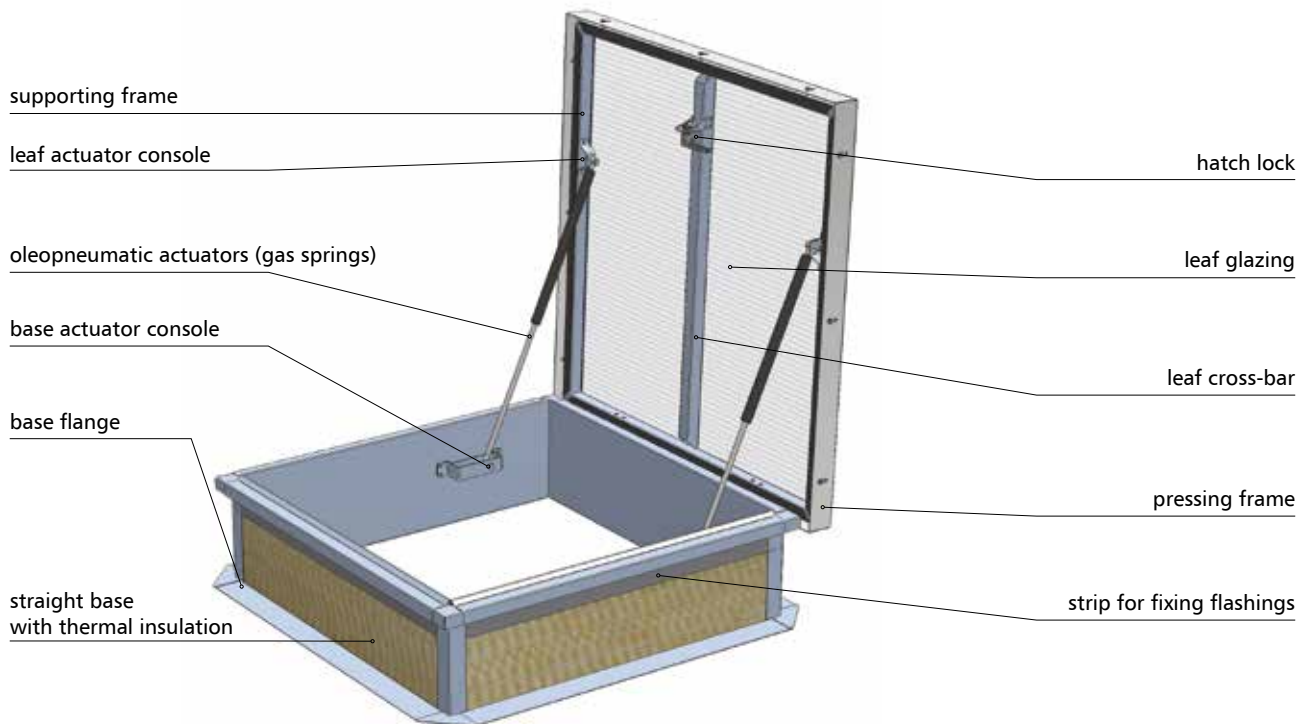

Fig.19 mcr PROLIGHT C roof hatch design

2.3.3 | Non-standard options

- » hatch elements painted to any RAL color,
- » thermal insulation of base made of PIR panel of 30 mm thickness, heat transfer coefficient $U=0.68 \text{ W/m}^2\text{K}$,
- » custom base height 160 mm ÷ 750 mm,
- » base made of aluminium sheet of 2,00 mm thickness,
- » installation of additional protective element in the form of anti-burglar grid or openable safety net.

2.3.4 | Technical drawings

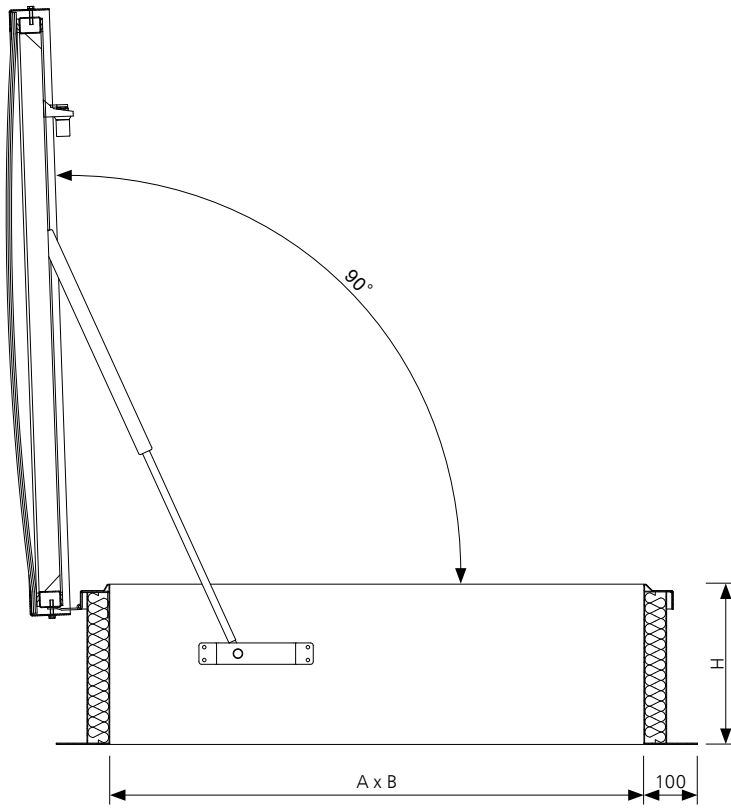

Fig.20 Section B-B of mcr PROLIGHT C roof hatch in open position, dimensions in [mm]

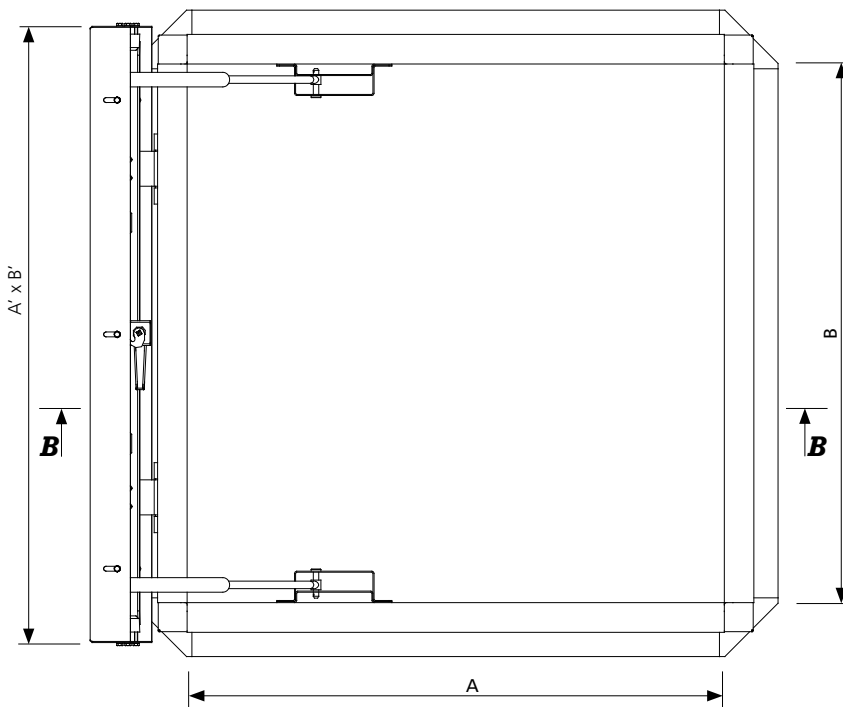

Fig.21 Top view of mcr PROLIGHT C roof hatch in open position, dimensions in [mm]

A, B – nominal dimensions [mm], clear opening of roof hatch
 A', B' – total dimensions of roof hatch leaf [mm], $A' = A + 135$ mm, $B' = B + 135$ mm
 H – roof hatch base height [mm]

2.3.5 | Technical details

Type WYŁAZU	NOMINAL DIMENSIONS(*)	ESTIMATED WEIGHT(**)
	A x B [mm]	[kg]
C 80	800 x 800	51
C 90	900 x 900	57
C 100	1000 x 1000	63
C 110	1100 x 1100	69
C 120	1200 x 1200	72
C 125	1250 x 1250	75
C 130	1300 x 1300	81
C 135	1350 x 1350	84
C 140	1400 x 1400	87
E 80/90	800 x 900	54
E 80/100	800 x 1000	57
E 80/110	800 x 1100	59
E 80/120	800 x 1200	62
E 80/130	800 x 1300	64
E 80/140	800 x 1400	66
E 80/150	800 x 1500	69
E 90/100	900 x 1000	60
E 90/110	900 x 1100	63
E 90/120	900 x 1200	65
E 90/130	900 x 1300	68
E 90/140	900 x 1400	71
E 90/150	900 x 1500	73
E 100/110	1000 x 1100	66
E 100/120	1000 x 1200	69
E 100/130	1000 x 1300	72
E 100/140	1000 x 1400	75
E 100/150	1000 x 1500	82
E 110/120	1100 x 1200	72
E 110/130	1100 x 1300	75
E 110/140	1100 x 1400	78
E 110/150	1100 x 1500	81
E 120/130	1200 x 1300	79
E 120/140	1200 x 1400	81
E 120/150	1200 x 1500	89

(*) Intermediate roof hatch dimensions between the values specified in the table are possible.

(**) Estimated weight specified for roof hatch of base height 500 mm, of standard configuration with multi-chamber polycarbonate panel glazing of 16 mm thickness.

2.4. | Roof hatches with skew base – type NG-A

2.4.1 | Technical description of standard

- » classification in accordance with EN 1873 (ref. to units with translucent glazing),
- » NG-A type roof hatches (squared and rectangular) smoke vents for flat and pitched roofs covered with roofing paper or PVC membrane,
- » dimensional range for roof hatches: 70x70 cm ÷ 150x160 cm,
- » skew base of height 300 mm or 500 mm made of galvanized steel sheet of 1.25 mm thickness,
- » bottom part of base has a circumferential flange of width 100 mm, through which the base is fitted to the roof structure,
- » upper part of base profiled to allow water run-off,
- » thermal insulation of base made of mineral wool of thickness 20 mm; heat transfer coefficient $U=1.41 \text{ W/m}^2\text{K}$,
- » galvanized steel sheet circumferential strip in upper part of base allows fixing of roof flashing,
- » leaf glazing: multi-chamber polycarbonate panel, acrylic dome, solid polycarbonate dome, sandwich panel, multi-chamber polycarbonate panel and single or double-layer acrylic dome or solid polycarbonate dome, multi-chamber polycarbonate panel with aluminum envelope cover and glazing of $B_{\text{ROOF}}(t1)$ class (see details in section 4),
- » hatch equipped in two gas springs for easy opening to 90° open position.

2.4.2 | Roof hatch design

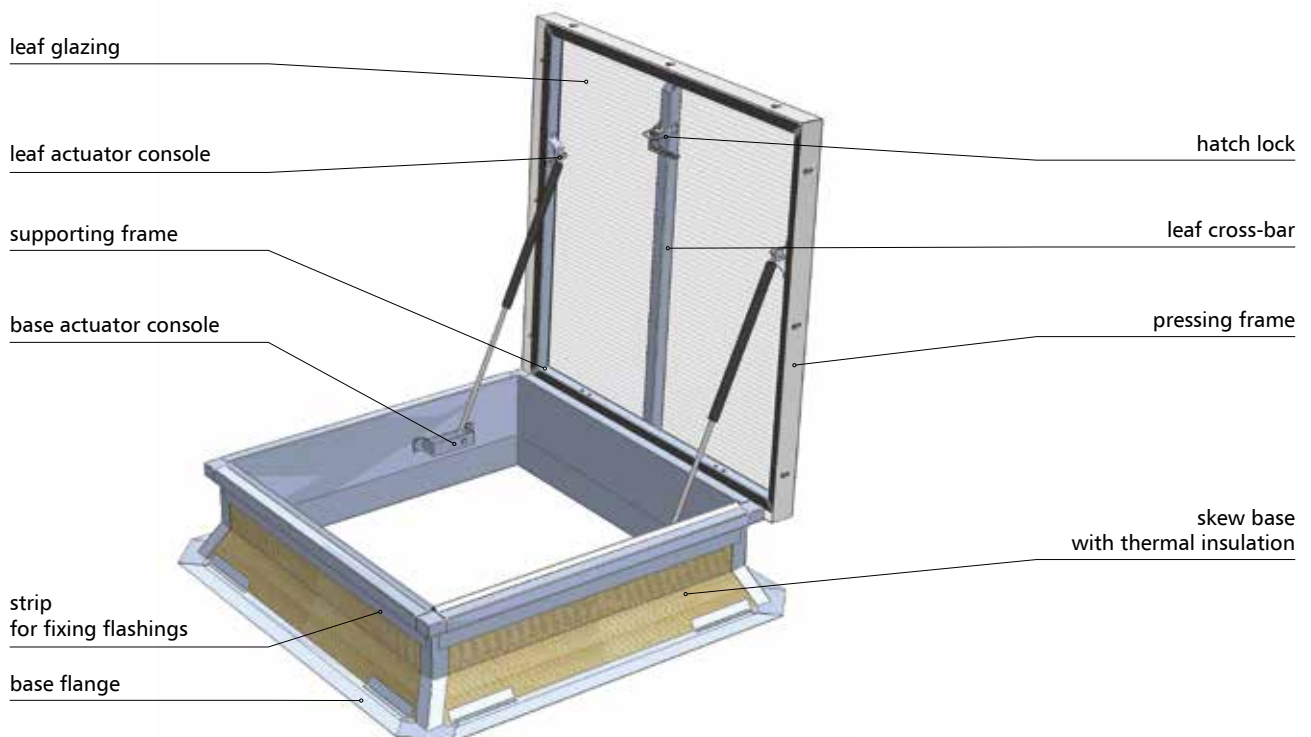

Fig.22 mcr PROLIGHT NG-A roof hatch design

2.4.3 | Non-standard options

- » hatch elements painted to any RAL color,
- » thermal insulation of base – PIR panel of 30 mm thickness, heat transfer coefficient $U=0.68 \text{ W/m}^2\text{K}$,
- » custom base height 160 mm ÷ 750 mm,
- » base made of aluminium sheet of 2,00 mm thickness,
- » installation of additional protective element in the form of anti-burglar grid or openable safety net.

2.4.4 | Technical drawings

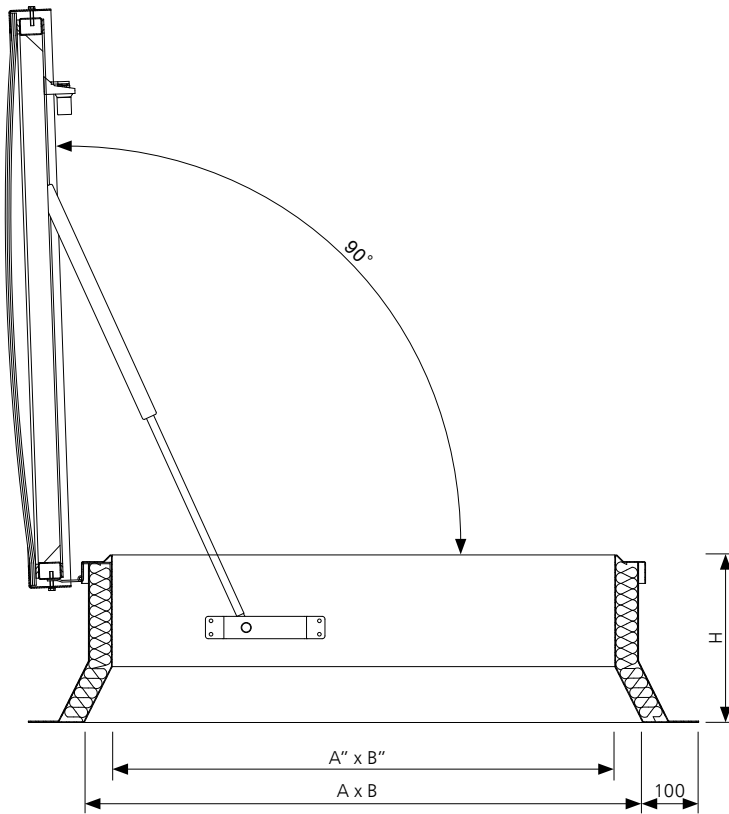

Fig.23 Section B-B of mcr PROLIGHT NG-A roof hatch in open position, dimensions in [mm]

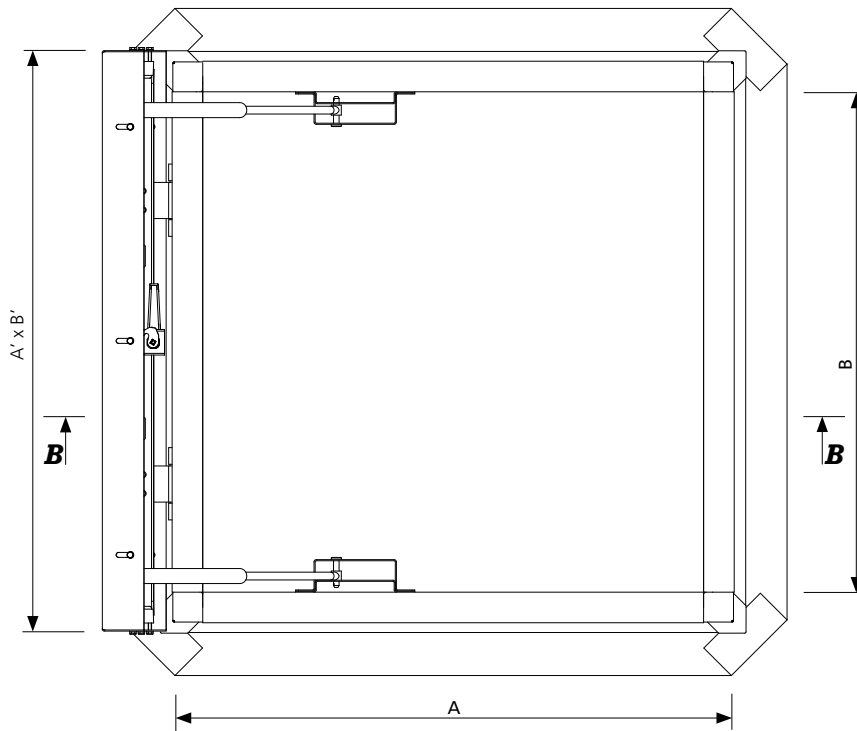

Fig.24 Top view of mcr PROLIGHT NG-A roof hatch in open position, dimensions in [mm]

A, B – nominal dimensions [mm], clear opening of roof hatch
 A', B' – total dimensions of roof hatch leaf [mm], A'=A+135 mm, B'=B+135 mm
 A'', B'' – clear dimensions of roof hatch upper opening [mm], A''=A-100 mm, B''=B-100 mm
 H – roof hatch base height [mm]

2.4.5 | Technical details

ROOF HATCHES Type	NOMINAL DIMENSIONS(*)	ESTIMATED WEIGHT(**)
	A x B [mm]	[kg]
NG-A 100/100	1000 x 1000	78
NG-A 100/110	1000 x 1100	81
NG-A 100/120	1000 x 1200	84
NG-A 100/130	1000 x 1300	87
NG-A 100/140	1000 x 1400	90
NG-A 100/150	1000 x 1500	96
NG-A 120/120	1200 x 1200	91
NG-A 120/130	1200 x 1300	94
NG-A 120/140	1200 x 1400	97
NG-A 120/150	1200 x 1500	104
NG-A 125/125	1250 x 1250	94
NG-A 130/130	1300 x 1300	97
NG-A 130/140	1300 x 1400	100
NG-A 130/150	1300 x 1500	108
NG-A 140/140	1400 x 1400	104
NG-A 140/150	1400 x 1500	111

(*) Intermediate roof hatch dimensions between the values specified in the table are possible.

(**) Estimated weight specified for roof hatch of base height 500 mm, of standard configuration with multi-chamber polycarbonate panel glazing of 16 mm thickness.

2.5. | Ventilation vents with straight base – type C, E

2.5.1 | Technical description of standard

- » classification in accordance with EN 1873 (ref. to units with translucent glazing),
- » C type ventilation vents (squared) and E type (rectangular) for flat and pitched roofs covered with roofing paper or PVC membrane,
- » dimensional range for ventilation vents:
 - C type squared vents: 80x90 ÷ 200x250 cm,
 - E type rectangular vents: 100x120 cm ÷ 195x300 cm,
- » straight base of height 300 mm or 500 mm made of galvanized steel sheet of 1.25 mm thickness
- » bottom part of base has a circumferential flange of width 100 mm, through which the base is fitted to the roof structure,
- » upper part of base profiled to allow water run-off,
- » thermal insulation of base made of mineral wool of thickness 20 mm; heat transfer coefficient $U=1.41 \text{ W/m}^2\text{K}$,
- » galvanized steel sheet circumferential strip in upper part of base allows fixing of roof flashing,
- » ventilation control 230V,
- » leaf glazing: multi-chamber polycarbonate panel, acrylic dome, solid polycarbonate dome, sandwich panel, multi-chamber polycarbonate panel and single or double-layer acrylic dome or solid polycarbonate dome, multi-chamber polycarbonate panel with aluminum envelope cover and glazing of B_{ROOF} (t1) class (see details in section 4).

2.5.2 | Ventilation vent design

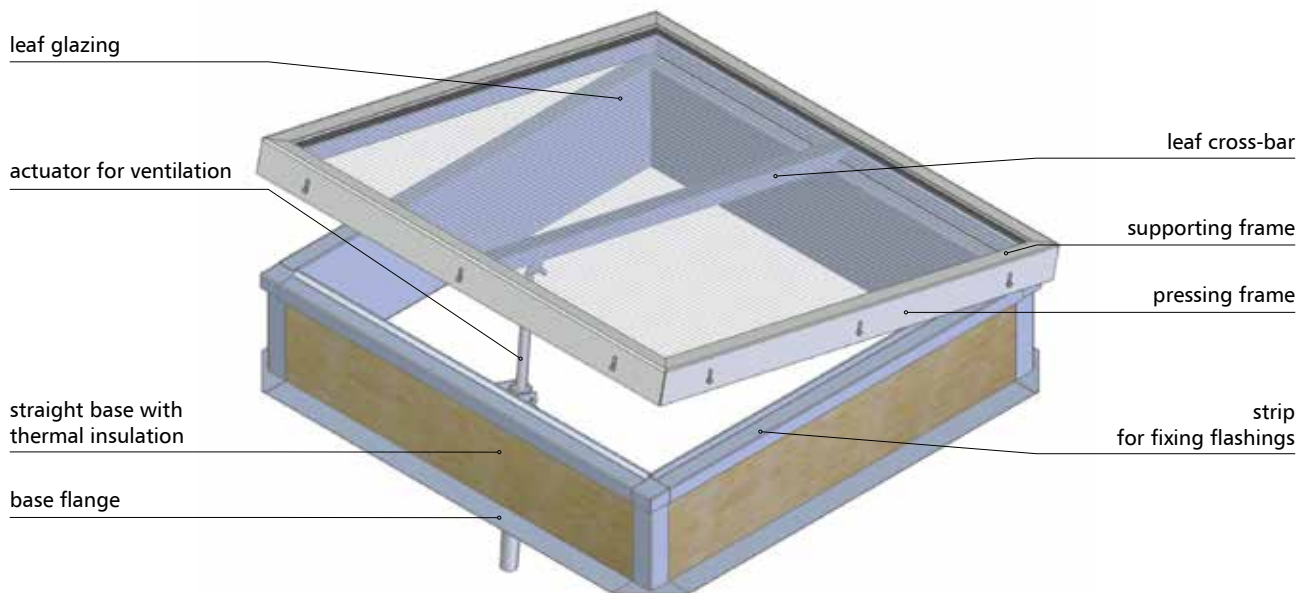

Fig.25 mcr PROLIGHT C ventilation vent design with electric actuator for ventilation

2.5.3 | Non-standard options

- » vent elements painted to any RAL color,
- » thermal insulation of base made of PIR panel of 30 mm thickness, heat transfer coefficient $U=0.68 \text{ W/m}^2\text{K}$,
- » custom dimensions of clear opening of vent base,
- » custom base height within 160 mm ÷ 700 mm,
- » custom width of circumferential flange of base,
- » base made of aluminium sheet of 2,00 mm thickness,
- » installation of additional protective elements in the form of anti-burglar grid or safety net,
- » available in configuration with soft body impact resistance up to 1200 J,
- » circumferential strip for fixing roof flashings made of PVC coated metal sheet,

2.5.4 | Technical drawings

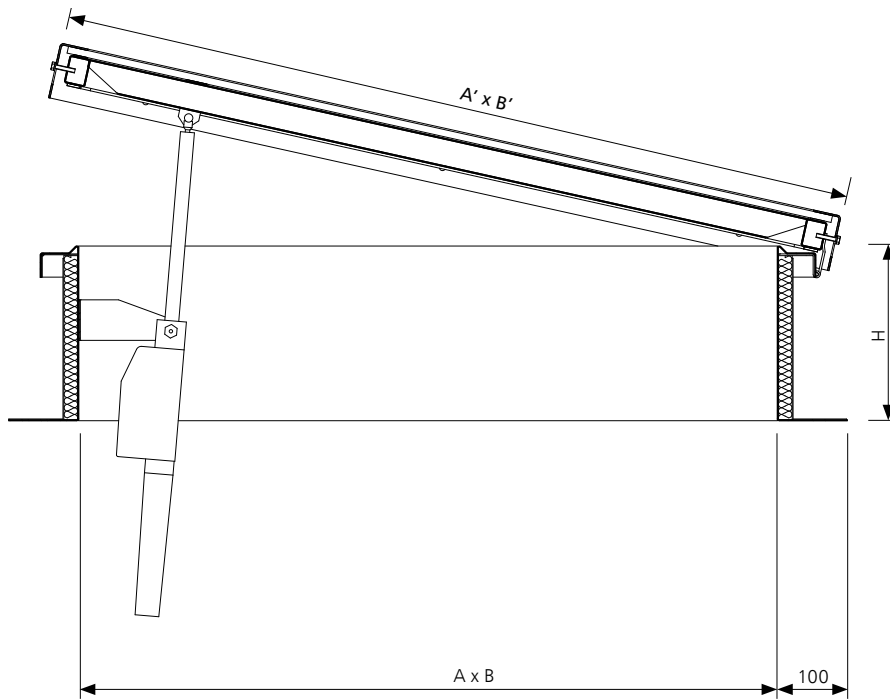

Fig.26 Section **B-B** of mcr PROLIGHT E ventilation vent in open position, dimensions in [mm]

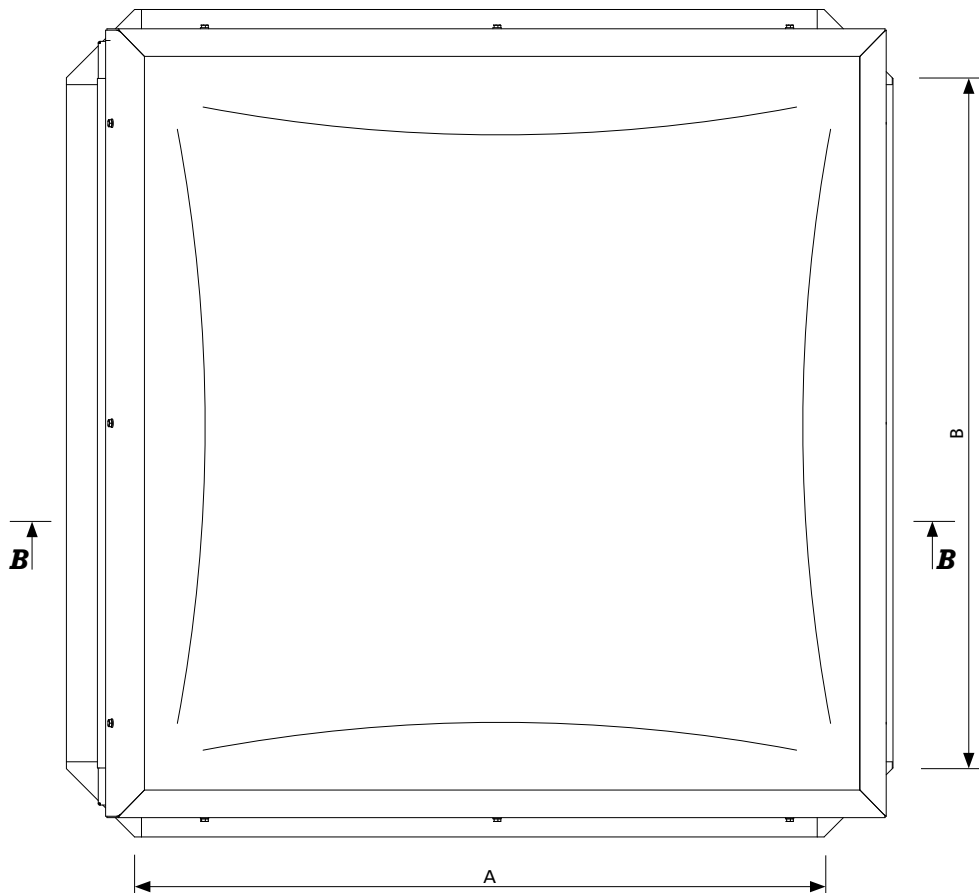

Fig.27 Top view of mcr PROLIGHT E ventilation vent in open position, dimensions in [mm]

A, B – nominal dimensions [mm] of ventilation vent
 A', B' – total dimensions of ventilation vent $A' = A + 135$ mm, $B' = B + 135$ mm
 H – ventilation vent base height [mm]

2.5.5 | Technical details

VENT Type	NOMINAL DIMENSIONS(*)	GEOMETRIC SURFACE	ESTIMATED WEIGHT(**)
	A x B [mm]	[m ²]	[kg]
C 80	800 x 800	0,64	49
C 90	900 x 900	0,81	54
C 100	1000 x 1000	1,00	60
C 110	1100 x 1100	1,21	70
C 115	1150 x 1150	1,32	73
C 120	1200 x 1200	1,44	76
C 125	1250 x 1250	1,56	79
C 130	1300 x 1300	1,69	82
C 135	1350 x 1350	1,82	85
C 140	1400 x 1400	1,96	88
C 150	1500 x 1500	2,25	103
C 155	1550 x 1550	2,40	106
C 160	1600 x 1600	2,56	110
C 170	1700 x 1700	2,89	116
C 180	1800 x 1800	3,24	123
C 190	1900 x 1900	3,61	130
C 195	1950 x 1950	3,80	133
C 200	2000 x 2000	4,00	137
E 100/120	1000 x 1200	1,20	70
E 100/130	1000 x 1300	1,30	73
E 100/140	1000 x 1400	1,40	76
E 100/150	1000 x 1500	1,50	83
E 100/160	1000 x 1600	1,60	86
E 100/180	1000 x 1800	1,80	92
E 100/190	1000 x 1900	1,90	95
E 100/200	1000 x 2000	2,00	101
E 100/210	1000 x 2100	2,10	104
E 100/220	1000 x 2200	2,20	107
E 100/230	1000 x 2300	2,30	110
E 100/240	1000 x 2400	2,40	113
E 100/250	1000 x 2500	2,50	116
E 110/200	1100 x 2000	2,20	105
E 115/200	1150 x 2000	2,30	107
E 120/140	1200 x 1400	1,68	82
E 120/150	1200 x 1500	1,80	90
E 120/170	1200 x 1700	2,04	99
E 140/150	1400 x 1500	2,10	100
E 140/180	1400 x 1800	2,52	109
E 140/200	1400 x 2000	2,80	116
E 140/250	1400 x 2500	3,50	131
E 150/160	1500 x 1600	2,40	106
E 150/180	1500 x 1800	2,70	112
E 150/200	1500 x 2000	3,00	119
E 150/210	1500 x 2100	3,15	122
E 150/240	1500 x 2400	3,60	132
E 150/250	1500 x 2500	3,75	135
E 160/180	1600 x 1800	2,88	116
E 160/190	1600 x 1900	3,04	119

VENT Type	NOMINAL DIMENSIONS(*)	GEOMETRIC SURFACE	ESTIMATED WEIGHT(**)
	A x B [mm]	[m ²]	[kg]
E 160/200	1600 x 2000	3,20	123
E 160/220	1600 x 2200	3,52	129
E 160/230	1600 x 2300	3,68	132
E 160/240	1600 x 2400	3,84	135
E 180/200	1800 x 2000	3,60	130
E 180/220	1800 x 2200	3,96	136
E 180/240	1800 x 2400	4,32	143
E 180/250	1800 x 2500	4,50	146
E 190/200	1900 x 2000	3,80	134
E 195/250	1950 x 2500	5,85	155

(*) Intermediate ventilation vent dimensions between the values specified in the table are possible.

(**) Estimated weight specified for ventilation vent of base height 500 mm, of standard configuration with multi-chamber polycarbonate panel glazing of 16 mm thickness, with electric control.

2.6. | Ventilation vents with skew base – type NG-A

2.6.1 | Technical description of standard

- » classification in accordance with EN 1873 (ref. to units with translucent glazing),
- » NG-A type (squared and rectangular) ventilation vents for flat and pitched roofs covered with roofing paper or PVC membrane,
- » dimensional range for NG-A type ventilation vents: 90x90 ÷ 200x250 cm/ 210x210 cm,
- » skew base of height 300 mm or 500 mm made of galvanized steel sheet of 1.25 mm thickness,
- » bottom part of base has a circumferential flange of width 100 mm, through which the base is fitted to the roof structure,
- » upper part of base profiled to allow water run-off,
- » thermal insulation of base made of mineral wool of thickness 20 mm; heat transfer coefficient $U=1.41 \text{ W/m}^2\text{K}$,
- » galvanized steel sheet circumferential strip in upper part of base allows fixing of roof flashing,
- » leaf glazing: multi-chamber polycarbonate panel, acrylic dome, solid polycarbonate dome, sandwich panel, multi-chamber polycarbonate panel and single or double-layer acrylic dome or solid polycarbonate dome, multi-chamber polycarbonate panel with aluminum envelope cover and glazing of B_{ROOF} (t1) class (see details in section 4),
- » ventilation control: pneumatic or ~230V electric.

2.6.2 | Ventilation vent design

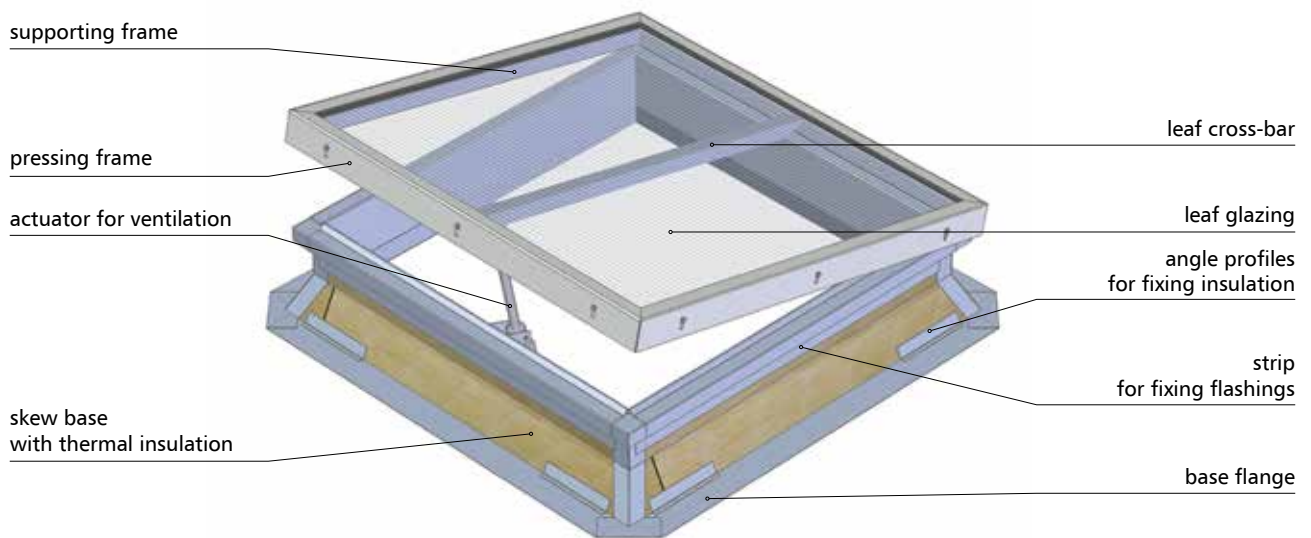

Fig.28 mcr PROLIGHT C ventilation vent design with electric actuator for ventilation

2.6.3 | Non-standard options

- » vent elements painted to any RAL color,
- » thermal insulation of base made of PIR panel of 30 mm thickness, heat transfer coefficient $U=0.68 \text{ W/m}^2\text{K}$,
- » custom base height 300 mm ÷ 700 mm,
- » base made of aluminium sheet of 2,00 mm thickness,
- » installation of additional protective elements in the form of anti-burglar grid or safety net,
- » available in configuration with soft body impact resistance up to 1200 J
- » circumferential strip for fixing roof flashings made of PVC coated metal sheet.

2.6.4 | Technical drawings

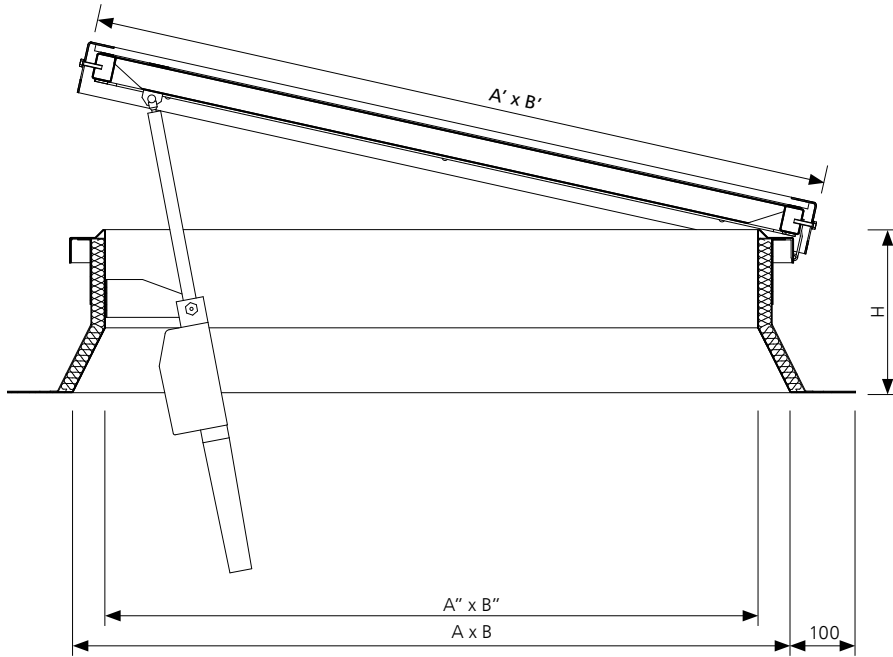

Fig.29 Section B-B of mcr PROLIGHT NG-A ventilation vent with skew base in open position, dimensions in [mm]

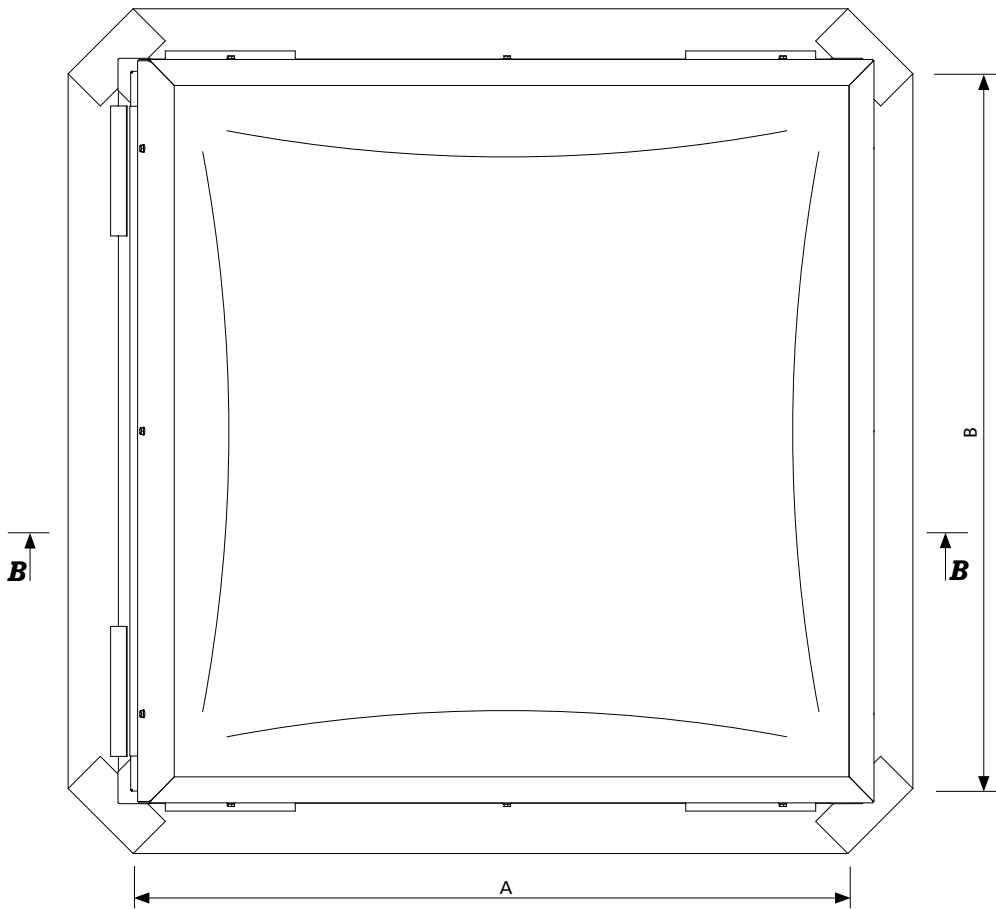

Fig.30 Top view of mcr PROLIGHT NG-A ventilation vent with skew base in open position, dimensions in [mm]

- A, B – nominal dimensions [mm] of ventilation vent
- A', B' – total dimensions of ventilation vent $A' = A + 135$ mm, $B' = B + 135$ mm
- A'', B'' – clear dimensions of ventilation vent upper opening $A'' = A - 100$ mm, $B'' = B - 100$ mm
- H – ventilation vent base height [mm]

2.6.5 | Technical details

VENT Type	NOMINAL DIMENSIONS(*)	GEOMETRIC SURFACE	ESTIMATED WEIGHT(**)
	A x B [mm]	[m ²]	[kg]
NG-A 100/100	1000 x 1000	0,81	66
NG-A 100/110	1000 x 1100	0,90	69
NG-A 100/120	1000 x 1200	0,99	72
NG-A 100/130	1000 x 1300	1,08	75
NG-A 100/140	1000 x 1400	1,17	78
NG-A 100/150	1000 x 1500	1,26	84
NG-A 100/160	1000 x 1600	1,35	88
NG-A 100/170	1000 x 1700	1,44	91
NG-A 100/180	1000 x 1800	1,53	94
NG-A 100/190	1000 x 1900	1,62	98
NG-A 100/200	1000 x 2000	1,71	101
NG-A 100/210	1000 x 2100	1,80	104
NG-A 100/220	1000 x 2200	1,89	107
NG-A 100/230	1000 x 2300	1,98	110
NG-A 100/240	1000 x 2400	2,07	116
NG-A 100/250	1000 x 2500	2,16	120
NG-A 120/120	1200 x 1200	1,21	79
NG-A 120/130	1200 x 1300	1,32	82
NG-A 120/140	1200 x 1500	1,43	85
NG-A 120/150	1200 x 1600	1,54	92
NG-A 120/170	1200 x 1700	1,76	98
NG-A 120/180	1200 x 1800	1,87	102
NG-A 120/190	1200 x 1900	1,98	105
NG-A 120/200	1200 x 2000	2,09	111
NG-A 120/210	1200 x 2100	2,20	115
NG-A 120/220	1200 x 2200	2,31	118
NG-A 120/230	1200 x 2300	2,42	121
NG-A 120/240	1200 x 2400	2,53	124
NG-A 120/250	1200 x 2500	2,64	128
NG-A 125/125	1250 x 1250	1,32	82
NG-A 130/130	1300 x 1300	1,44	85
NG-A 130/140	1300 x 1400	1,56	88
NG-A 130/150	1300 x 1500	1,68	96
NG-A 130/160	1300 x 1600	1,80	99
NG-A 130/170	1300 x 1700	1,92	102
NG-A 130/180	1300 x 1800	2,04	109
NG-A 130/190	1300 x 1900	2,16	112
NG-A 130/200	1300 x 2000	2,28	115
NG-A 130/210	1300 x 2100	2,40	119
NG-A 130/220	1300 x 2200	2,52	122
NG-A 130/230	1300 x 2300	2,64	125
NG-A 130/240	1300 x 2400	2,76	129
NG-A 130/250	1300 x 2500	2,88	132
NG-A 140/140	1400 x 1400	1,69	92
NG-A 140/150	1400 x 1500	1,82	99
NG-A 140/160	1400 x 1600	1,95	103
NG-A 140/170	1400 x 1700	2,08	109
NG-A 140/180	1400 x 1800	2,21	113
NG-A 140/190	1400 x 1900	2,34	116
NG-A 140/200	1400 x 2000	2,47	119

VENT Type	NOMINAL DIMENSIONS(*)	GEOMETRIC SURFACE	ESTIMATED WEIGHT(**)
	A x B [mm]	[m ²]	[kg]
NG-A 140/210	1400 x 2100	2,60	123
NG-A 140/220	1400 x 2200	2,73	126
NG-A 140/230	1400 x 2300	2,86	129
NG-A 140/240	1400 x 2400	2,99	133
NG-A 140/250	1400 x 2500	3,12	136
NG-A 150/150	1500 x 1500	1,96	103
NG-A 150/160	1500 x 1600	2,10	110
NG-A 150/170	1500 x 1700	2,24	113
NG-A 150/180	1500 x 1800	2,38	116
NG-A 150/190	1500 x 1900	2,52	120
NG-A 150/200	1500 x 2000	2,66	123
NG-A 150/210	1500 x 2100	2,80	127
NG-A 150/220	1500 x 2200	2,94	130
NG-A 150/230	1500 x 2300	3,08	134
NG-A 150/240	1500 x 2400	3,22	137
NG-A 150/250	1500 x 2500	3,36	140
NG-A 160/160	1600 x 1600	2,25	114
NG-A 160/170	1600 x 1700	2,40	117
NG-A 160/180	1600 x 1800	2,55	120
NG-A 160/190	1600 x 1900	2,70	124
NG-A 160/200	1600 x 2000	2,85	127
NG-A 160/210	1600 x 2100	3,00	131
NG-A 160/220	1600 x 2200	3,15	134
NG-A 160/230	1600 x 2300	3,30	137
NG-A 160/240	1600 x 2400	3,45	140
NG-A 160/250	1600 x 2500	3,60	144
NG-A 170/170	1700 x 1700	2,56	121
NG-A 170/180	1700 x 1800	2,72	124
NG-A 170/190	1700 x 1900	2,88	128
NG-A 170/200	1700 x 2000	3,04	131
NG-A 170/210	1700 x 2100	3,20	135
NG-A 170/220	1700 x 2200	3,36	138
NG-A 170/230	1700 x 2300	3,52	141
NG-A 170/240	1700 x 2400	3,68	145
NG-A 170/250	1700 x 2500	3,84	148
NG-A 180/180	1800 x 1800	2,89	128
NG-A 180/190	1800 x 1900	3,06	132
NG-A 180/200	1800 x 2000	3,23	135
NG-A 180/210	1800 x 2100	3,23	139
NG-A 180/220	1800 x 2200	3,57	142
NG-A 180/230	1800 x 2300	3,74	146
NG-A 180/240	1800 x 2400	3,91	149
NG-A 180/250	1800 x 2500	4,08	152
NG-A 180/260	1800 x 2600	4,25	156
NG-A 180/270	1800 x 2700	4,42	159
NG-A 180/280	1800 x 2800	4,59	162
NG-A 180/290	1800 x 2900	4,76	165
NG-A 180/300	1800 x 3000	4,93	169
NG-A 190/190	1900 x 1900	3,24	136
NG-A 190/200	1900 x 2000	3,42	139

VENT Type	NOMINAL DIMENSIONS(*)	GEOMETRIC SURFACE	ESTIMATED WEIGHT(**)
	A x B [mm]	[m ²]	[kg]
NG-A 190/210	1900 x 2100	3,60	143
NG-A 190/220	1900 x 2200	3,78	146
NG-A 190/230	1900 x 2300	3,96	150
NG-A 190/240	1900 x 2400	4,14	153
NG-A 190/250	1900 x 2500	4,32	156
NG-A 190/260	1900 x 2600	4,50	160
NG-A 190/270	1900 x 2700	4,68	163
NG-A 190/280	1900 x 2800	4,86	167
NG-A 190/290	1900 x 2900	5,04	170
NG-A 190/300	1900 x 3000	5,22	173
NG-A 200/200	2000 x 2000	3,61	143
NG-A 200/210	2000 x 2100	3,80	147
NG-A 200/220	2000 x 2200	3,99	150
NG-A 200/230	2000 x 2300	4,18	154
NG-A 200/240	2000 x 2400	4,37	157
NG-A 200/250	2000 x 2500	4,56	161
NG-A 200/260	2000 x 2600	4,75	164
NG-A 200/270	2000 x 2700	4,94	167
NG-A 200/280	2000 x 2800	5,13	171
NG-A 200/290	2000 x 2900	5,32	174
NG-A 200/300	2000 x 3000	5,51	178
NG-A 210/210	2100 x 2100	4,00	151

(*) Intermediate ventilation vent dimensions between the values specified in the table are possible.

(**) Estimated weight specified for ventilation vent of base height 500 mm, of standard configuration with multi-chamber polycarbonate panel glazing of 16 mm thickness, with electric control.

2.6.6 | Ventilation vents control

For correct operation, ventilation vents require connecting to devices controlling their opening and closing. A set of such devices constitutes a complete ventilation control system. Depending on the type of devices used, it may be designed as a:

- electric ~230V ventilation control system,
- pneumatic ventilation control system.

3 | Installation of smoke vents, ventilation vents, fixed skylights and roof hatches

3.1 | Smoke vent with steel straight base fixed onto reinforced concrete structure

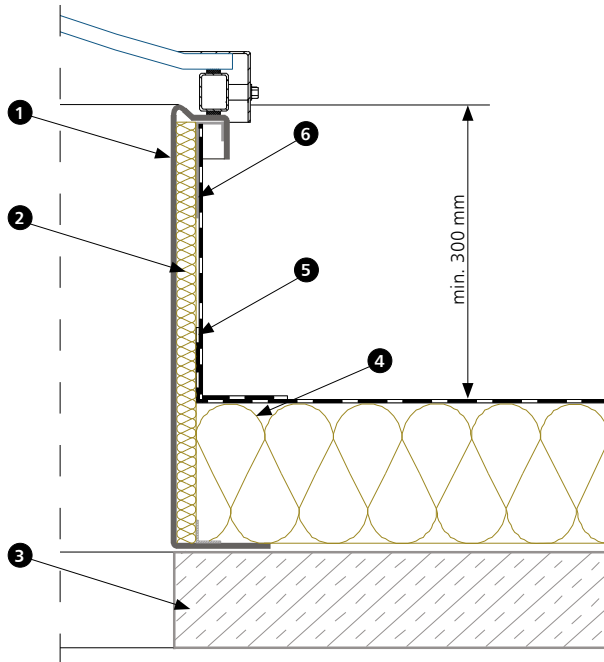

- 1. smoke vent steel base
- 2. thermal insulation of base
- 3. ceiling, e.g. reinforced concrete slab
- 4. thermal insulation of roof
- 5. PVC membrane
- 6. PVC coated sheet

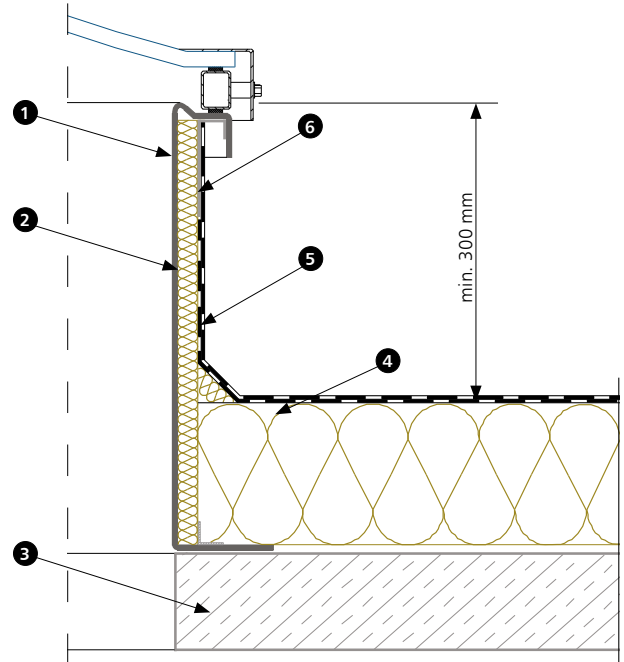

- 1. smoke vent steel base
- 2. thermal insulation of base
- 3. ceiling, e.g. reinforced concrete slab
- 4. thermal insulation of roof
- 5. roofing paper
- 6. galvanized steel sheet

3.2 | Smoke vent with steel straight base fixed onto steel roof

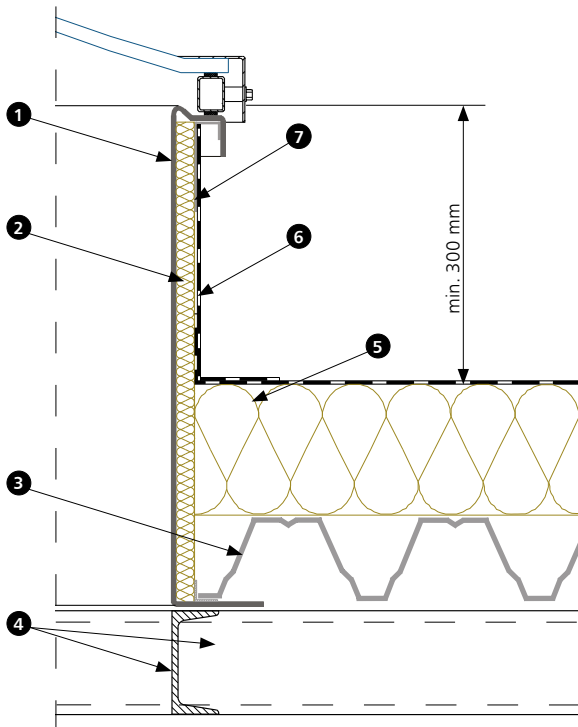

- 1. smoke vent steel base
- 2. thermal insulation of base
- 3. trapezoidal metal sheet
- 4. supporting steel profile
- 5. thermal insulation of roof
- 6. PVC membrane
- 7. PVC coated sheet

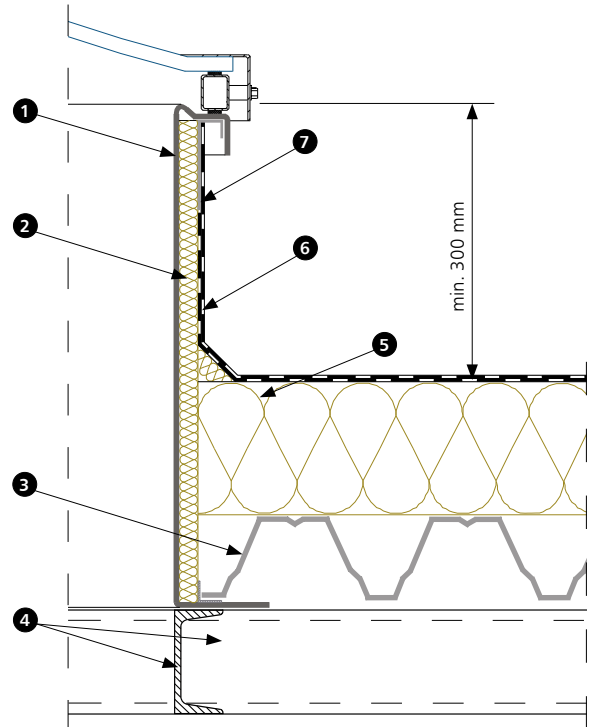

- 1. smoke vent steel base
- 2. thermal insulation of base
- 3. trapezoidal metal sheet
- 4. supporting steel profile
- 5. thermal insulation of roof
- 6. roofing paper
- 7. galvanized steel sheet

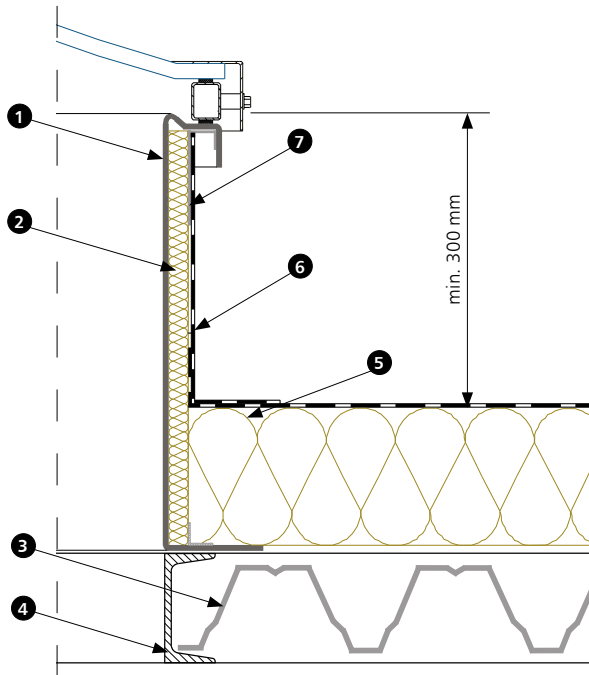

1. smoke vent steel base
2. thermal insulation of base
3. trapezoidal metal sheet
4. supporting steel profile
5. thermal insulation of roof
6. PVC membrane
7. PVC coated sheet

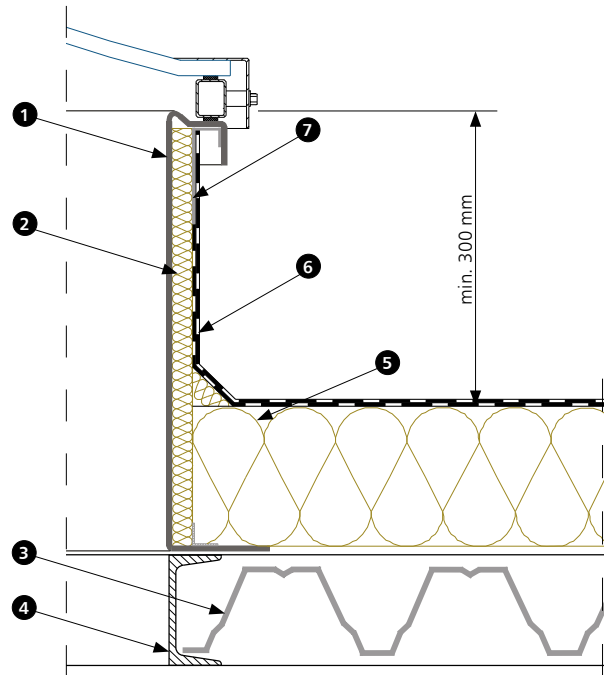

1. smoke vent steel base
2. thermal insulation of base
3. trapezoidal metal sheet
4. supporting steel profile
5. thermal insulation of roof
6. roofing paper
7. galvanized steel sheet

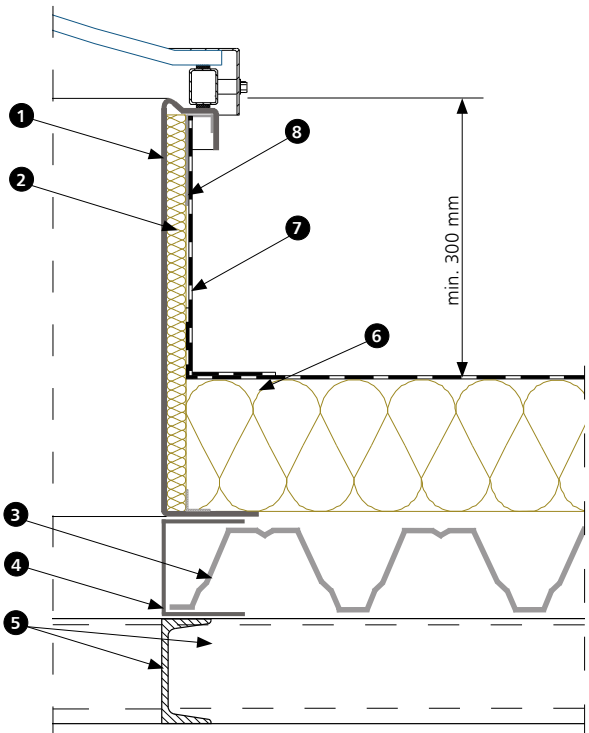

1. smoke vent steel base
2. thermal insulation of base
3. trapezoidal metal sheet
4. additional flashing
5. supporting steel profile
6. thermal insulation of roof
7. PVC membrane
8. PVC coated sheet

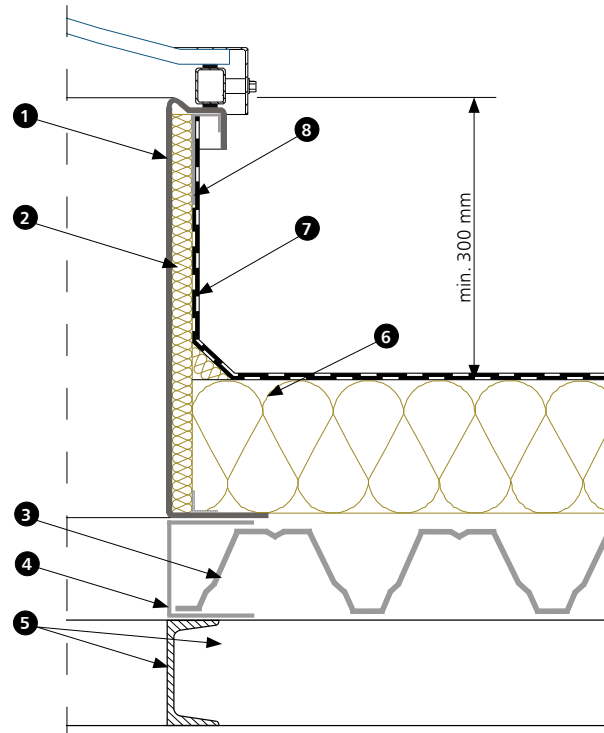

1. smoke vent steel base
2. thermal insulation of base
3. trapezoidal metal sheet
4. additional flashing
5. supporting steel profile
6. thermal insulation of roof
7. roofing paper
8. galvanized steel sheet

3.3 | Smoke vent with steel straight base fixed onto steel plinth

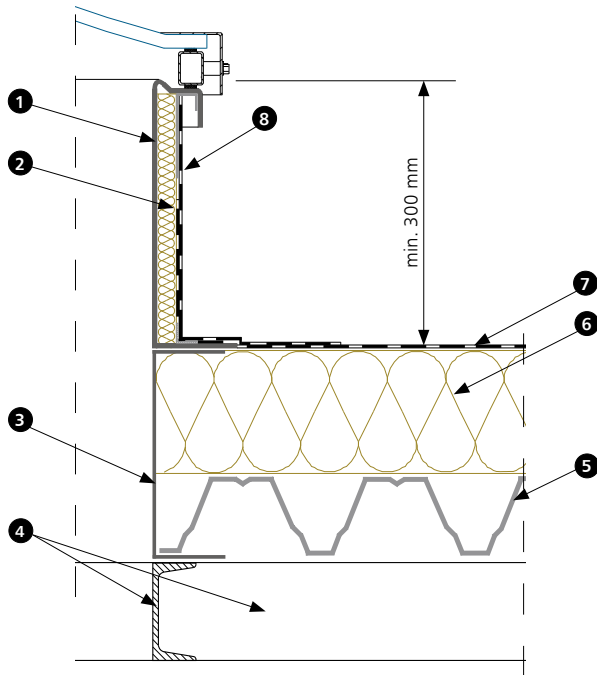

1. smoke vent steel straight base 300 mm
2. thermal insulation of base
3. additional plinth
4. supporting steel profile
5. trapezoidal metal sheet
6. thermal insulation of roof
7. PVC membrane
8. PVC coated sheet

3.4 | Smoke vent with plinth type straight base fixed onto reinforced concrete plinth

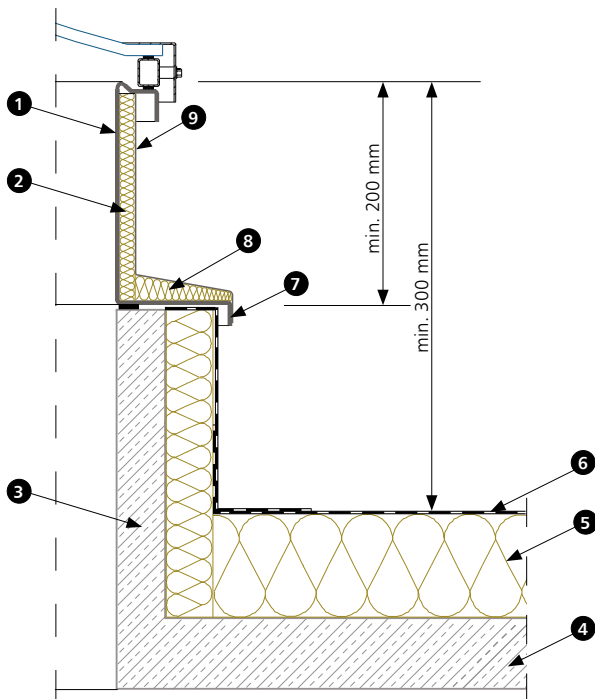

1. smoke vent steel base
2. thermal insulation of base
3. reinforced concrete plinth (*)
4. ceiling, e.g. reinforced concrete slab
5. thermal insulation of roof
6. PVC membrane
7. drip cap
8. thermal insulation of cover plate
9. galvanized steel sheet

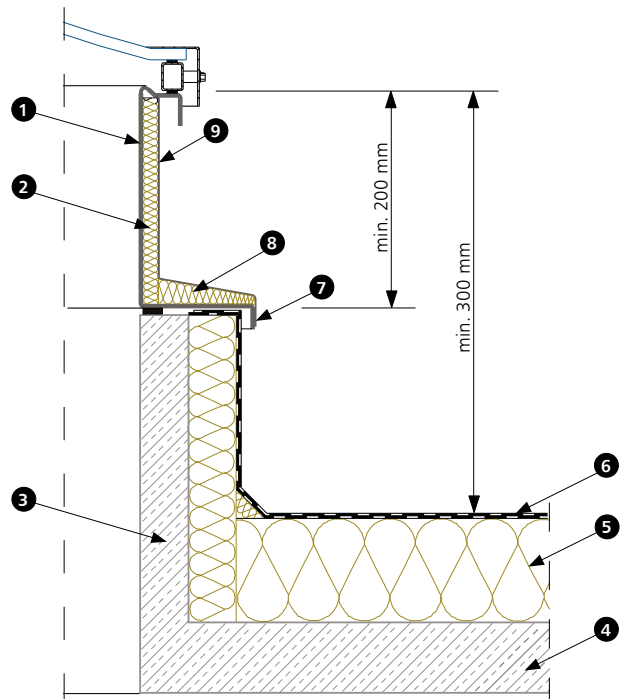

1. smoke vent steel base
2. thermal insulation of base
3. reinforced concrete plinth(*)
4. ceiling, e.g. reinforced concrete slab
5. thermal insulation of roof
6. roofing paper
7. drip cap
8. thermal insulation of cover plate
9. galvanized steel sheet

(*) optional placing of overlay base on wooden or steel plinth

3.5 | Smoke vent with steel skew base fixed onto steel structure

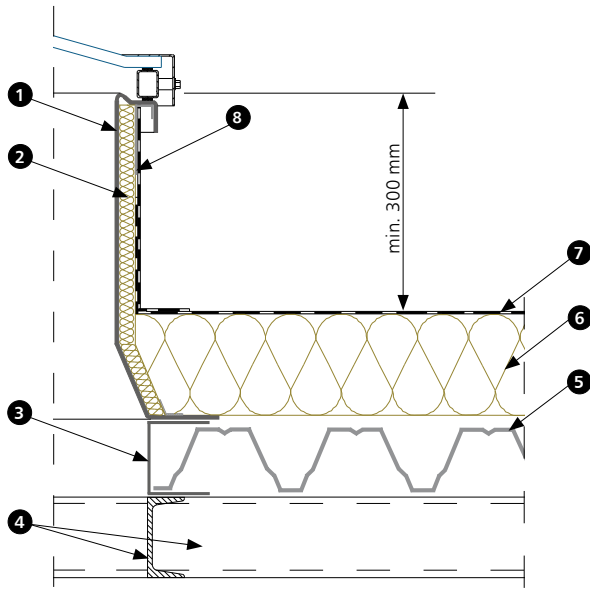

1. smoke vent steel skew base
2. thermal insulation of base
3. additional flashing
4. supporting steel profile
5. trapezoidal metal sheet
6. thermal insulation of roof
7. PVC membrane
8. PVC coated sheet

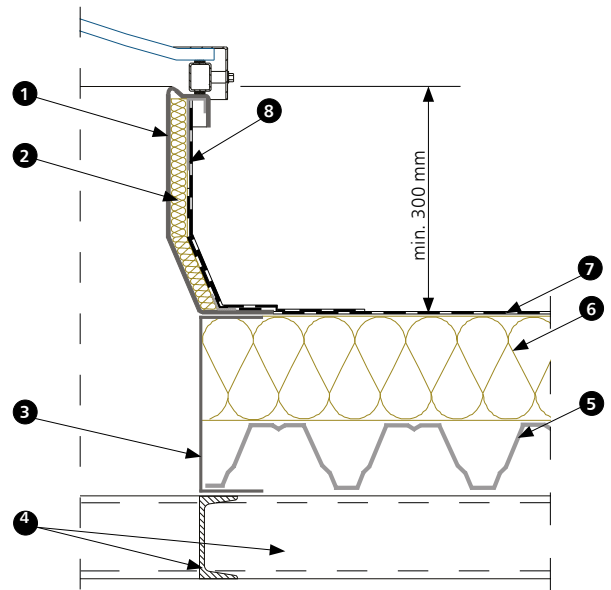







1. smoke vent steel skew base 300 mm
2. thermal insulation of base
3. additional flashing
4. supporting steel profile
5. trapezoidal metal sheet
6. thermal insulation of roof
7. PVC membrane
8. PVC coated sheet

4 | **Smoke vents and ventilation vents, skylights and hatches glazing**

A broad range of glazing options is available for vents, skylights and hatches used as sources of daylight. Choosing the right glazing will have impact on:

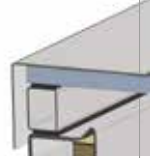
- » sunlight intensity,
- » thermal insulation of building, and
- » operating safety.

		Multi-chamber polycarbonate panel (PCA)	3x PMMA or PC dome	2x PMMA or PC dome	ALU sandwich panel(*)	Multi-chamber polycarbonate panel and ALU envelope cover (*)	B _{ROOF} (t1)(**)	2x PMMA or PC dome and PCA panel (***)
Product type								
Smoke vents	C	•	•	•	•	•	•	•
	E	•	•	•	•	•	•	•
	NG-A	•	•	•	•	•	•	•
	DVP, DVPS	•	-	-	•	•	•	-
Fixed skylights	C, E	•	•	•	-	-	•	•
	NG-A	•	•	•	-	-	•	•
Roof hatches	C, E	•	•	•	•	•	•	•
	NG-A	•	•	•	•	•	•	•
Ventilation vents	C, E	•	•	•	•	•	•	•
	NG-A	•	•	•	•	•	•	•

*) Blind aluminum glazing in version:
 - ALU sandwich panel (aluminum-thermal insulation-aluminum)
 Aluminum envelope cover with multi-chamber polycarbonate panel

(**) B_{ROOF}(t1) glazing (multi-chamber polycarbonate of thickness ≥ 10 mm and polyester panel)

(***) Applies to selected vent sizes

GLAZING SYMBOLS:

- PCA - multi-chamber polycarbonate
- PMMA - acrylate
- PC - solid polycarbonate

4.1 | Multi-chamber polycarbonate panel (PCA)

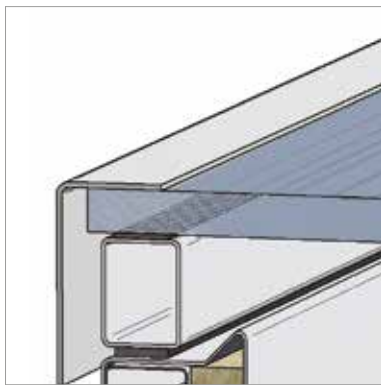

multi-chamber polycarbonate panel

Fig.31 Vent glazing – multi-chamber polycarbonate panel

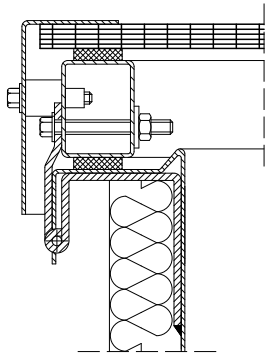

Fig.32 Vent section, glazing: multi-chamber polycarbonate panel

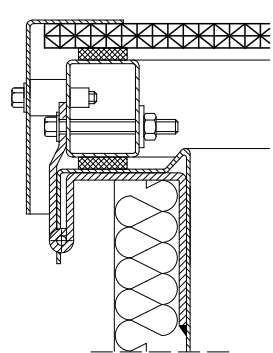
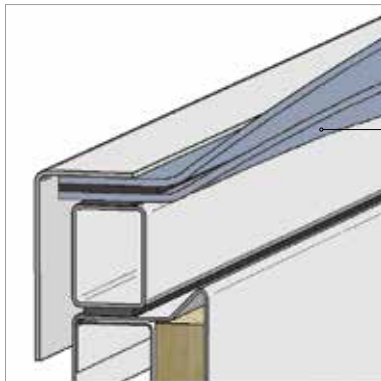

Fig.33 Vent section, glazing: structured multi-chamber polycarbonate panel

PARAMETERS	PCA 10 mm			PCA 16 mm		
	CLEAR	OPAL	BLACK	CLEAR	OPAL	BLACK
HEAT TRANSFER COEFFICIENT U	2,2÷2,5 W/m ² K	2,2÷2,5 W/m ² K	2,5 W/m ² K	1,77÷2,0 W/m ² K	1,77÷2,0 W/m ² K	1,8 W/m ² K
LIGHT TRANSMISION L _t	64÷65 %	44÷66 %	~0 %	54÷64 %	45÷47 %	~0 %
ACOUSTIC INSULATION R _w	18÷19 dB	18÷19 dB	18 dB	18÷19 dB	18÷19 dB	19 dB
FIRE PERFORMANCE (AS PER EN 13501-1)	B-s1,d0	B-s1,d0	B-s1,d0	B-s1,d0 / B-s2,d0	B-s1,d0 / B-s2,d0	B-s2,d0

PARAMETERS	PCA 20 mm			PCA 25 mm		
	CLEAR	OPAL	BLACK	CLEAR	OPAL	BLACK
HEAT TRANSFER COEFFICIENT U	1,59÷1,6 W/m ² K	1,59÷1,6 W/m ² K	1,6 W/m ² K	1,4 W/m ² K	1,4 W/m ² K	1,6 W/m ² K
LIGHT TRANSMISION L _t	53÷62 %	45÷47 %	~0 %	51 %	44 %	~0 %
ACOUSTIC INSULATION R _w	21 dB	21 dB	21 dB	22 dB	22 dB	22 dB
FIRE PERFORMANCE (AS PER EN 13501-1)	B-s1,d0 / B-s2,d0	B-s1,d0 / B-s2,d0	B-s2,d0	B-s2,d0	B-s2,d0	B-s2,d0

4.2 | PMMA acrylic dome



double-layer acrylic dome

Fig.34 Vent glazing – double-layer acrylic dome

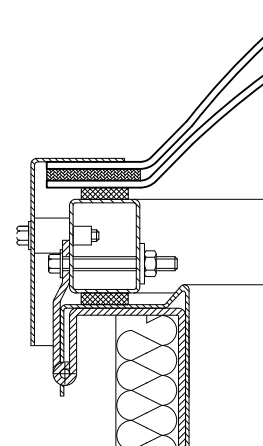
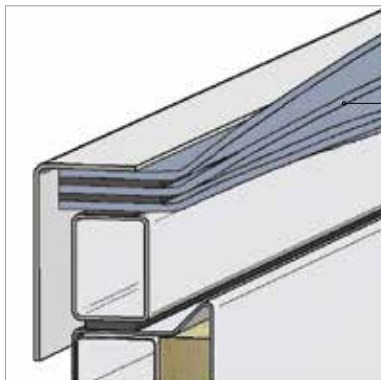

Fig.35 Vent section, glazing: double-layer acrylic dome



triple-layer acrylic dome (PMMA)

Fig.36 Vent glazing – triple-layer acrylic dome

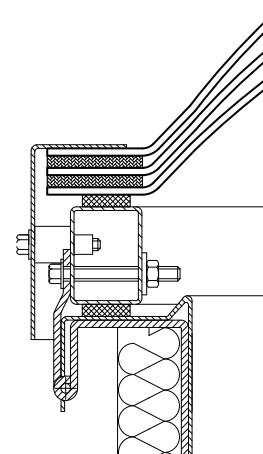
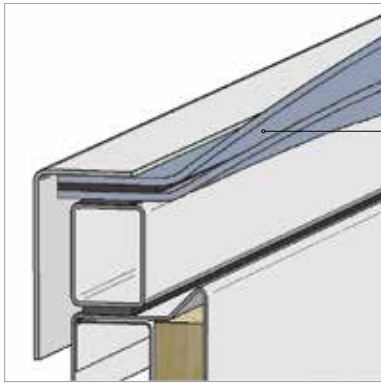

Fig.37 Vent section, glazing: triple-layer acrylic dome

PARAMETERS	DOUBLE-LAYER ACRYLIC DOME		TRIPLE-LAYER ACRYLIC DOME	
	CLEAR	OPAL	CLEAR	OPAL
HEAT TRANSFER COEFFICIENT U	2,2 W/m ² K	2,2 W/m ² K	1,5 W/m ² K	1,5 W/m ² K
LIGHT TRANSMISION L _t	85 %	68 - 75 %	78 %	64 %
ACOUSTIC INSULATION R _w	20 dB	20 dB	22 dB	22 dB
FIRE PERFORMANCE (AS PER EN 13501-1)	NPD	NPD	NPD	NPD

43 | **PC solid polycarbonate dome**



double-layer solid polycarbonate dome

Fig.38 Vent glazing – double-layer solid polycarbonate dome

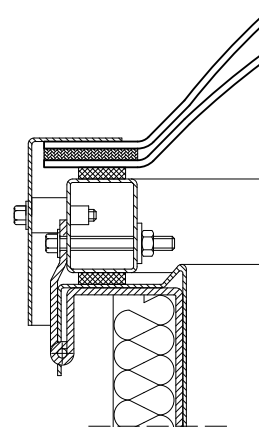
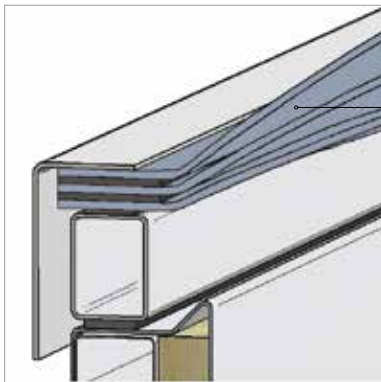

Fig.39 Vent section, glazing: double-layer solid polycarbonate dome



triple-layer solid polycarbonate dome

Fig.40 Vent glazing – triple-layer solid polycarbonate dome

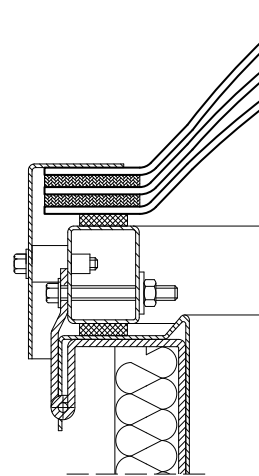

Fig.41 Vent section, glazing: triple-layer solid polycarbonate dome

PARAMETERS	DOUBLE-LAYER SOLID POLYCARBONATE DOME		TRIPLE-LAYER SOLID POLYCARBONATE DOME	
	CLEAR	OPAL	CLEAR	OPAL
HEAT TRANSFER COEFFICIENT U	2,2 W/m ² K	2,2 W/m ² K	1,5 W/m ² K	1,5 W/m ² K
LIGHT TRANSMISSION L _t	76÷79 %	26÷36 %	66÷70 %	23÷32 %
ACOUSTIC INSULATION R _w	20 dB	20 dB	22 dB	22 dB
FIRE PERFORMANCE (AS PER EN 13501-1)	B-s1,d0 / B-s2,d0 / NPD	B-s1,d0 / B-s2,d0 / NPD	B-s1,d0 / B-s2,d0 / NPD	B-s1,d0 / B-s2,d0 / NPD

4.4 | **ALU sandwich panel**

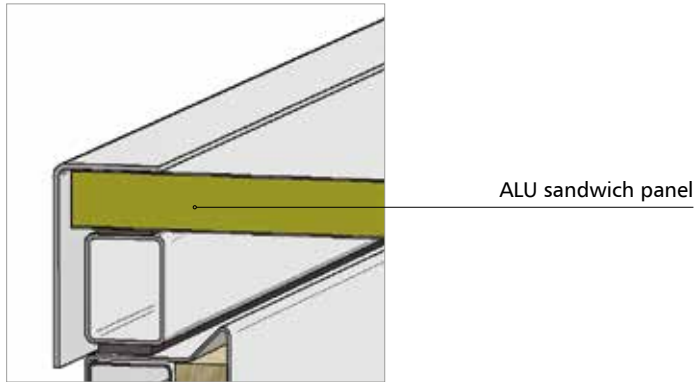

Fig.42 Vent glazing – ALU sandwich panel

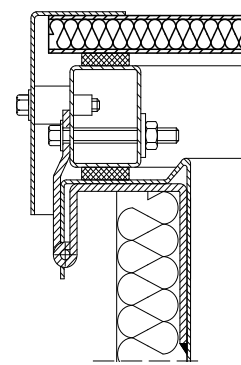

Fig.43 Vent section, glazing: ALU sandwich panel

PARAMETERS	ALU SANDWICH PANEL TH. 20 mm	ALU SANDWICH PANEL TH. 40 mm
HEAT TRANSFER COEFFICIENT U	1,4 W/m ² K	0,78 W/m ² K
LIGHT TRANSMISION L _t	blind	blind
FIRE PERFORMANCE (AS PER EN 13501-1)	E / NPD	E / NPD

4.5 | **ALU envelope cover with multi-chamber polycarbonate**

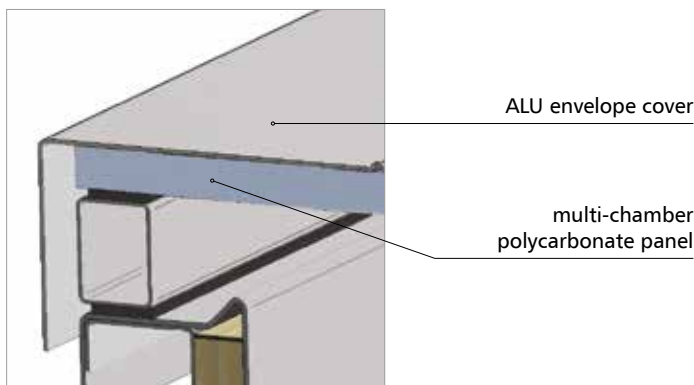

Fig.44 Vent glazing – ALU envelope cover with multi-chamber polycarbonate

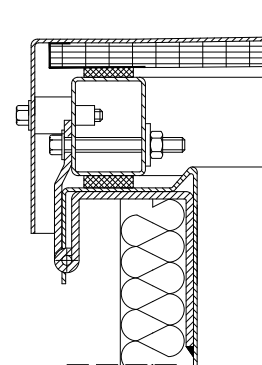

Fig.45 Vent section, glazing – ALU envelope cover with multi-chamber polycarbonate

PARAMETERS	10 mm	16 mm	20 mm	25 mm
HEAT TRANSFER COEFFICIENT U	2,2÷2,5 W/m ² K	1,77÷2,0 W/m ² K	1,59÷1,6 W/m ² K	1,4 W/m ² K
LIGHT TRANSMISION L _t	0 %	0%	0%	0%
ACOUSTIC INSULATION R _w	18÷19 dB	18÷19 dB	21 dB	22 dB
FIRE PERFORMANCE (AS PER EN 13501-1)	B-s1,d0	B-s1,d0/ B-s2,d0	B-s1,d0/ B-s2,d0	B-s2,d0

4.6 | **Single-layer acrylic dome (PMMA)/ solid polycarbonate (PC) dome and multi-chamber polycarbonate panel (PCA)**

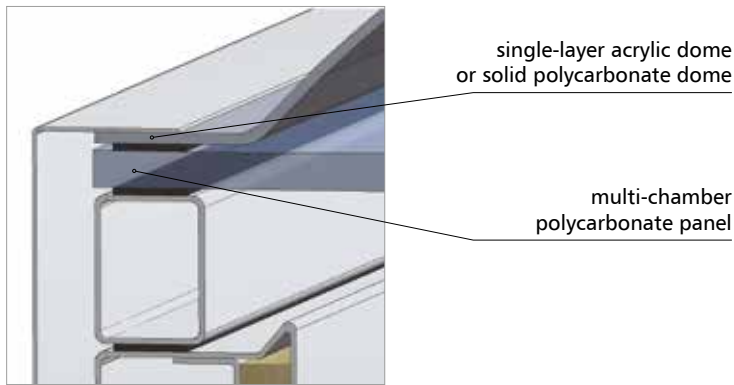

Fig.46 Vent filling – acrylic dome or solid polycarbonate dome and multi-chamber polycarbonate panel

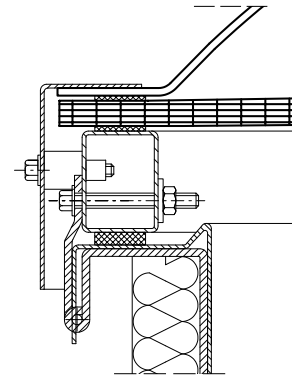

Fig.47 Vent section, glazing – acrylic dome or solid polycarbonate dome and multi-chamber polycarbonate panel

PARAMETERS	1xPMMA + PCA10	1xPC + PCA10	1xPMMA + PCA16	1xPC + PCA16
HEAT TRANSFER COEFFICIENT U	1,6 W/m ² K	1,6 W/m ² K	1,38 W/m ² K	1,38 W/m ² K
LIGHT TRANSMISION L _t (clear - clear)	59%	56÷57%	50÷59%	47÷57%
LIGHT TRANSMISION L _t (clear - opal)	51%	48÷49%	41÷43%	39÷42%
LIGHT TRANSMISION L _t (opal - opal)	45÷48%	35÷39%	37÷41%	29÷33%
ACOUSTIC INSULATION R _w	min. 19dB	min. 19dB	min. 21dB	min. 21dB
FIRE PERFORMANCE (AS PER EN 13501-1)	PMMA: NPD PCA10: B-s1,d0	PC: B-s1,d0 / B-s2,d0 /NPD PCA10: B-s1,d0	PMMA: NPD PCA16: B-s1,d0 / B-s2,d0	PC: B-s1,d0 / B-s2,d0 /NPD PCA10: B-s1,d0 / B-s2,d0

PARAMETERS	1xPMMA + PCA20	1xPC + PCA20	1xPMMA + PCA25	1xPC + PCA25
HEAT TRANSFER COEFFICIENT U	1,19÷1,26 W/m ² K	1,19÷1,26 W/m ² K	1,1 W/m ² K	1,1 W/m ² K
LIGHT TRANSMISION L _t (clear - clear)	49÷57%	46÷55%	47%	44÷45%
LIGHT TRANSMISION L _t (clear - opal)	41÷43%	39÷42%	40%	38÷39%
LIGHT TRANSMISION L _t (opal - opal)	37÷41%	29÷33%	36÷38%	28÷31%
ACOUSTIC INSULATION R _w	min. 21dB	min. 21dB	min. 22dB	min. 22dB
FIRE PERFORMANCE (AS PER EN 13501-1)	PMMA: NPD PCA20: B-s1,d0	PC: B-s1,d0 / B-s2,d0 /NPD PCA20: B-s1,d0	PMMA: NPD PCA25: B-s1,d0 / B-s2,d0	PC: B-s1,d0 / B-s2,d0 /NPD PCA25: B-s1, d0 / B-s2,d0

4.7 | **Double-layer acrylic dome (PMMA)/ solid polycarbonate (PC) dome and multi-chamber polycarbonate panel (PCA)**

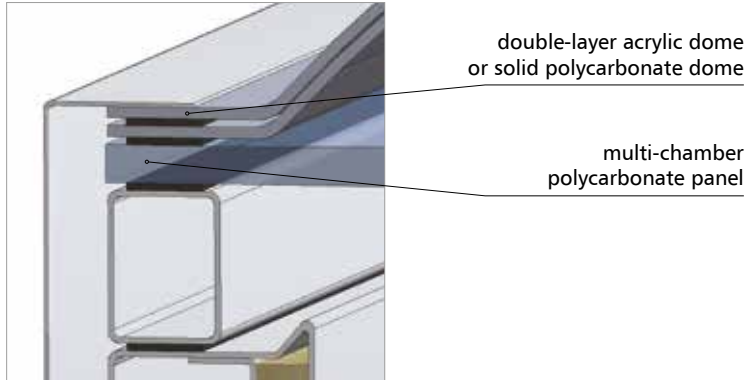

Fig.48 Vent filling – acrylic dome or solid polycarbonate dome and multi-chamber polycarbonate panel

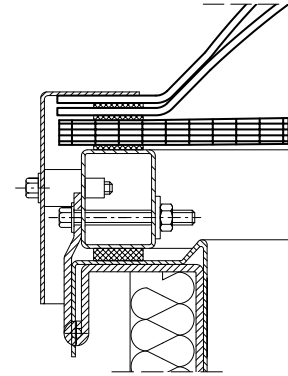

Fig.49 Vent section, glazing – acrylic dome or solid polycarbonate dome and multi-chamber polycarbonate panel

PARAMETERS	2xPMMA + PCA10	2xPC + PCA10	2xPMMA + PCA16	2xPC + PCA16
HEAT TRANSFER COEFFICIENT U	1,26 W/m ² K	1,26 W/m ² K	1,1 W/m ² K	1,1 W/m ² K
LIGHT TRANSMISSION L _t (clear - clear)	54%	49÷51%	46÷54%	41÷51%
LIGHT TRANSMISSION L _t (clear - opal)	47%	42÷43%	38÷40%	34÷37%
LIGHT TRANSMISSION L _t (opal - opal)	37÷41%	14÷20%	31÷35%	12÷17%
ACOUSTIC INSULATION R _w	min. 19dB	min. 19dB	min. 21dB	min. 21dB
FIRE PERFORMANCE (AS PER EN 13501-1)	PMMA: NPD PCA10: B-s1,d0	PC: B-s1,d0 / B-s2,d0 /NPD PCA10: B-s1,d0	PMMA: NPD PCA16: B-s1,d0 / B-s2,d0	PC: B-s1,d0 / B-s2,d0 /NPD PCA10: B-s1,d0 / B-s2,d0

PARAMETERS	2xPMMA + PCA20	2xPC + PCA20	2xPMMA + PCA25	2xPC + PCA25
HEAT TRANSFER COEFFICIENT U	1,0 W/m ² K	1,0 W/m ² K	0,95 W/m ² K	0,95 W/m ² K
LIGHT TRANSMISSION L _t (clear - clear)	45÷53%	40÷49%	43%	39÷40%
LIGHT TRANSMISSION L _t (clear - opal)	38÷40%	34÷37%	37%	33÷35%
LIGHT TRANSMISSION L _t (opal - opal)	31÷35%	12÷17%	30÷33%	11÷16%
ACOUSTIC INSULATION R _w	min. 21dB	min. 21dB	min. 22dB	min. 22dB
FIRE PERFORMANCE (AS PER EN 13501-1)	PMMA: NPD PCA20: B-s1,d0 / B-s2,d0	PC: B-s1,d0 / B-s2,d0 /NPD PCA20: B-s1,d0 / B-s2,d0	PMMA: NPD PCA25: B-s2,d0	PC: B-s1,d0 / B-s2,d0 /NPD PCA25: B-s2,d0

NOTE: The above configurations apply only to selected vent dimensions.

4.8 | **B_{roof}(t1) multi-chamber polycarbonate panel + polyester panel**

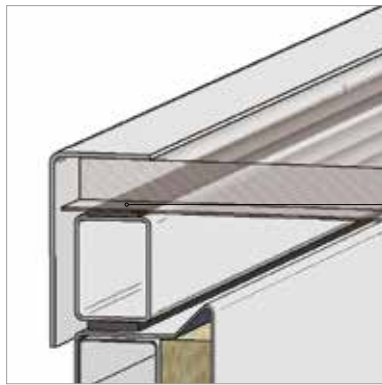

B_{roof}(t1) multi-chamber polycarbonate panel + polyester panel

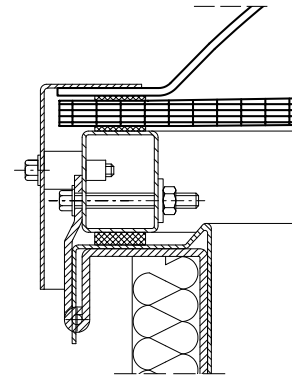

Fig.51 Vent section, glazing B_{roof}(t1)

Fig.50 Vent glazing – multi-chamber polycarbonate panel + polyester panel

PARAMETERS	B _{roof} (t1) - MULTI-CHAMBER POLYCARBONATE PANEL TH. 16 MM(*) + POLYESTER PANEL		
	CLEAR	OPAL	BLACK
HEAT TRANSFER COEFFICIENT U	1,77 ÷ 2,0 W/m ² K	1,77 ÷ 2,0 W/m ² K	2,0 W/m ² K
LIGHT TRANSMISSION L _t	44 ÷ 59 %	24 ÷ 49 %	~0%
ACOUSTIC INSULATION R _w	19 ÷ 21 dB	19 ÷ 21 dB	19 dB
FIRE PERFORMANCE (AS PER EN 13501-1)	B _{roof} (t1)	B _{roof} (t1)	B _{roof} (t1)

(*) B_{roof}(t1) glazing also available with multi-chamber polycarbonate panel of thickness 10 mm, 20 mm and 25 mm.

5. | Additional equipment for vents, skylights and hatches

	Product type	Smoke vents	Fixed skylights	roof hatches	Ventilation vents
Smoke vents with roof access option		•	-	-	-
Wind deflectors		•	-	-	-
Inlet deflector		•	-	-	-
Anti-burglar grid		•	•	•	•
Safety net		•	•	•	•
Overlay base N type		•	• (*)	•	•
Limit switch		•	-	-	•

(*) does not apply to round skylights

5.1. | Smoke vent with roof access option

5.1.1 | Technical description of standard

- » smoke vents mcr Prolight C100 (100x100 cm), C110 (110x110 cm), E100/110 (100x110 cm) and NG-A 120/120 (120x120 cm) - classification according to Certificate of Conformity EN 12101-2,
- » C, E type (squared and rectangular, single-leaf with straight base) smoke vents for flat and inclined roofs covered with roofing paper or PVC membrane,
- » straight base of height 300 mm or 500 mm made of galvanized steel sheet of 1.25 mm thickness,
- » bottom part of the base has a circumferential flange of width 100 mm, through which the base is fitted to the roof structure,
- » upper part of base has shape enabling water runoff,
- » thermal insulation of base made of mineral wool of thickness 20 mm; heat transfer coefficient $U=1.41 \text{ W/m}^2\text{K}$
- » circumferential strip in the upper part of base, made of galvanized steel sheet, used for fixing roof work,
- » single-leaf vent leaf opening angle min. 140° ,
- » hinges fixing the leaf to base installed at lengthwise side of vent,
- » leaf glazing: multi-chamber polycarbonate panel, acrylic dome, solid polycarbonate dome, sandwich panel, multi-chamber polycarbonate panel and single or double-layer acrylic dome or solid polycarbonate dome, multi-chamber polycarbonate panel with aluminum envelope cover and glazing of B_{ROOF} (t1) class (details in section 4),
- » smoke exhausting control: electric 24V, through single or double actuators installed at the sides, for use of vent as revision roof hatch (roof access function),
- » attention: wind deflectors and inlet deflector are not recommended due to possible damage.

5.1.2.1 | Design of smoke vent with roof access function and single actuator - C100, C110, E100/110 NG-A 120/120

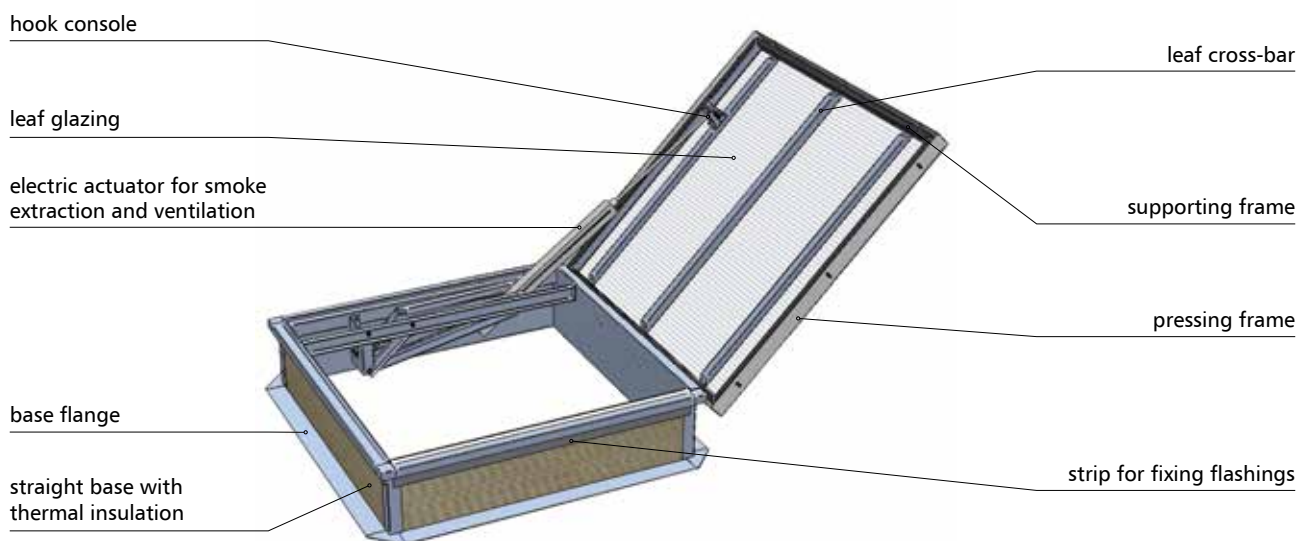

Fig.52 mcr PROLIGHT C100 smoke vent with roof access function and electric control for smoke extraction and ventilation

5.1.3 | Smoke vent with roof access option

- » vent elements painted to any RAL color - applies to wind deflectors and base,
- » thermal insulation of base – panel of 30 mm thickness, heat transfer coefficient $U=0.68 \text{ W/m}^2\text{K}$,
- » base made of aluminium sheet of 2,0 mm thickness,
- » custom dimensions of clear opening of vent base,
- » custom base height within 200 mm* ÷ 700 mm,
- » custom width of circumferential flange of base,
- » circumferential strip for fixing roof flashings made of PVC coated metal sheet,
- » custom base design,
- » broad range of optional accessories.

(*) Base height below 300 mm available only if a plinth is designed for the vent, ensuring total height (vent+plinth) of min. 300 mm.

5.1.4 | Available dimensions

VENT Type	NOMINAL DIMENSIONS	ACTIVE AREA A_z [m ²]		ELECTRIC CONTROL**
	A x B	STANDARD (WITHOUT WIND DEFLECTOR AND INLET DEFLECTOR)		POWER CONSUMPTION [A] BY ELECTRIC ACTUATOR FOR CLASS
	[mm]	BASE OF MIN. H=500 mm	BASE OF MIN. H=300 mm	SL 250
C 100	1000 x 1000	0,72	0,64	1 x 1,6
C 110	1100 x 1100	0,85	0,74	1 x 1,6
E 100/110	1000 x 1100	0,79	0,69	1 x 1,6
NG-A 120/120(*)	1200 x 1200	0,99	0,97	1 x 1,6

(*) mcr PROLIGHT smoke vent NG-A 120/120 with skew base and wind deflectors.

(**) Power consumption specified in the table applies to smoke vent with multi-chamber polycarbonate glazing.

5.1.5 | Technical drawings of smoke vent with roof access option and single actuator
- C100, C110, E100/110 NG-A 120/120

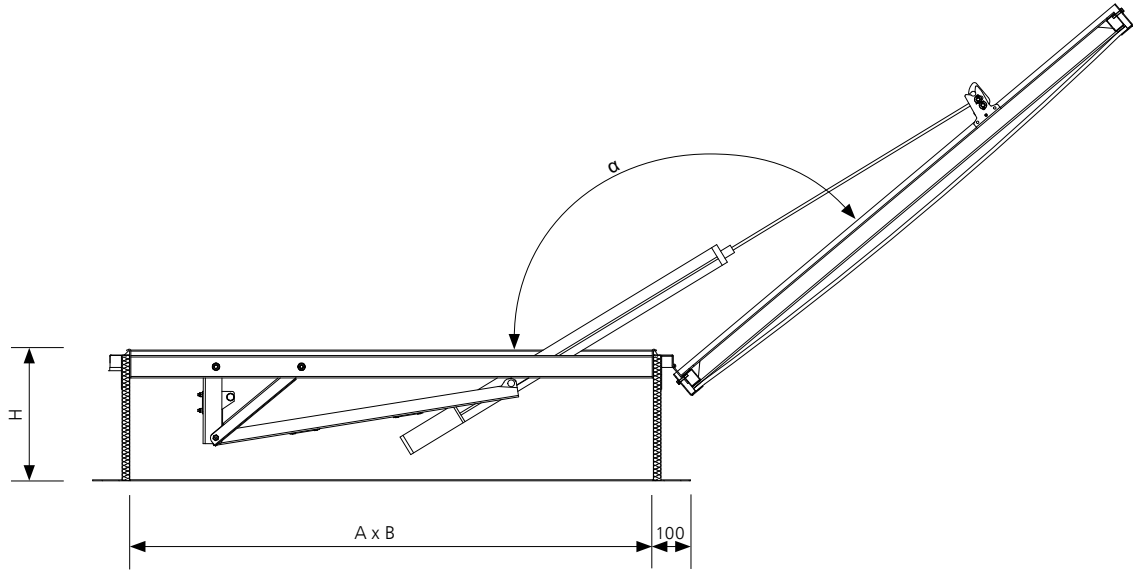

Fig.53 Section **B-B** of mcr PROLIGHT C100 with roof access function in open position, dimensions in [mm]

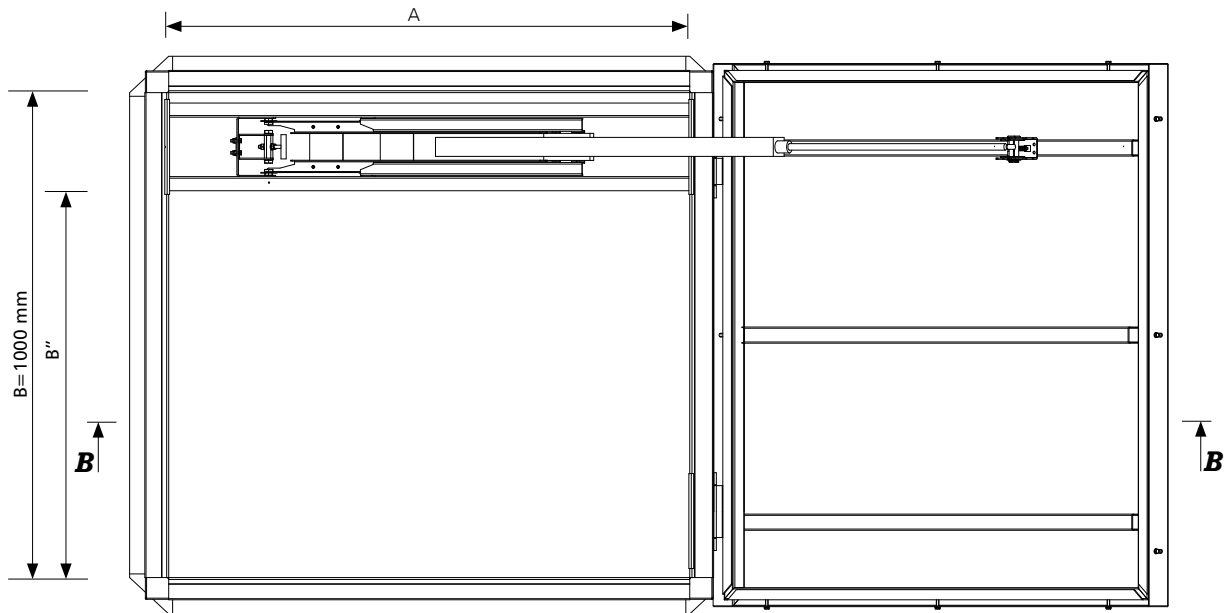

Fig.54 Top view of mcr PROLIGHT C100 with roof access function in open position, dimensions in [mm]

- A, B – nominal dimensions [mm], clear opening of smoke vent
- B'' – clear opening, passage B'' = B - 195 mm
- H – smoke vent base height [mm]
- α – smoke vent opening angle $\alpha \geq 140^\circ$

5.2 | Wind deflectors

- » a smoke vent element increasing its active area,
- » wind deflectors are used in:
 - mcr PROLIGHT vents of C, E and DVP type as optional accessory,
 - mcr PROLIGHT NG-A type, mcr PROLIGHT DVPS type as standard accessory,
- » consists of wind shield fixed to the base with mounting consoles,
- » wind shields made of aluminum sheet; mounting consoles made of galvanized steel sheet,
- » wind shields delivered as separate elements to be assembled on site (with previously installed mounting consoles),
- » non-standard options:
 - powder coating of wind deflectors.

Wind deflectors are installed in smoke vents in pairs:

- » at corners of the vent base, opposite to the hinges side (PROLIGHT C, E, NG-A type vents),
- » along side walls of the base (mcr PROLIGHT DVP, DVPS type).



Fig.55 Wind deflectors in single-leaf smoke vents

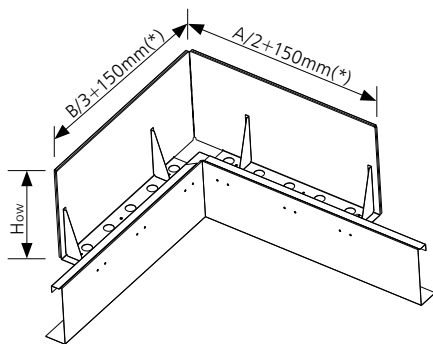

Fig.56 Wind deflectors inside view

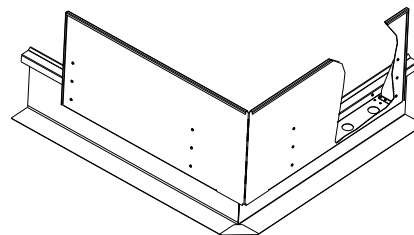

Fig.57 Wind deflectors outside view

Vent type	Wind deflector height
C / E	100 mm ÷ 450 mm
DVP	100 mm ÷ 370 mm
DVPS	100 mm ÷ 390 mm
NG-A	230 mm ÷ 530 mm

Wind deflector height depends on:

- » smoke vent type,
- » nominal dimensions of smoke vent,
- » base height,
- » inlet deflector applied as optional accessory.

A, B – nominal smoke vent dimensions [mm]

H_{low} – wind deflector height [mm]

(*) – mcr PROLIGHT C and E type vents

mcr PROLIGHT DVP, DVPS type vents: A-100 mm

mcr NG-A type vents: A/2+100 mm

5.3 | Inlet deflector

- » element of a smoke vent that increases its active area; always used alongside wind deflectors,
- » inlet deflectors are used in:
 - mcr PROLIGHT C type, mcr PROLIGHT E type, mcr PROLIGHT DVP type vents as optional accessory,
- » made of galvanized steel sheet,
- » the application of inlet deflector determines wind deflectors height,
- » the lower edge of inlet deflector protrudes 70 mm below the base,
- » in case of fitting inlet deflector and anti-burglar grid or safety net together, the minimum vent base height should be:
 - 300 mm for mcr PROLIGHT C and E type vents,
 - 310 mm for mcr PROLIGHT DVP type vents,
- » non-standard options:
 - powder coating of inlet deflector,
 - aluminum sheet or stainless steel making.

In order to avoid damage, inlet deflector is installed in the so-called transport position - above the lower base edge. After installing smoke vent on the roof, the inlet deflector should be lowered to working position.

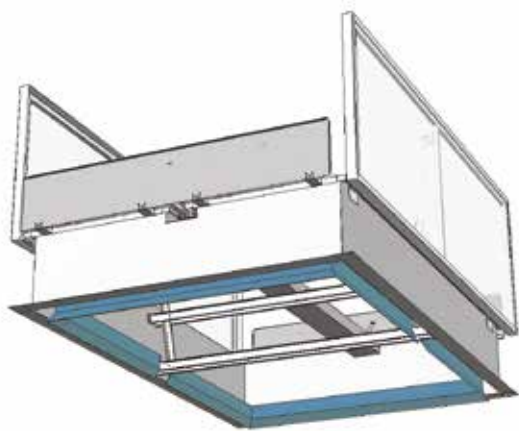

Fig.58 Inlet deflector installed in mcr PROLIGHT DVP type vent

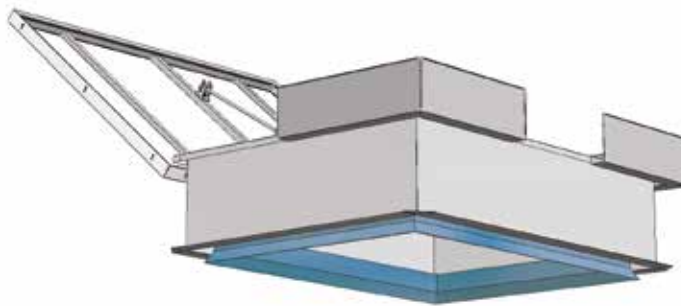

Fig.59 Inlet deflector installed in mcr PROLIGHT E type vent

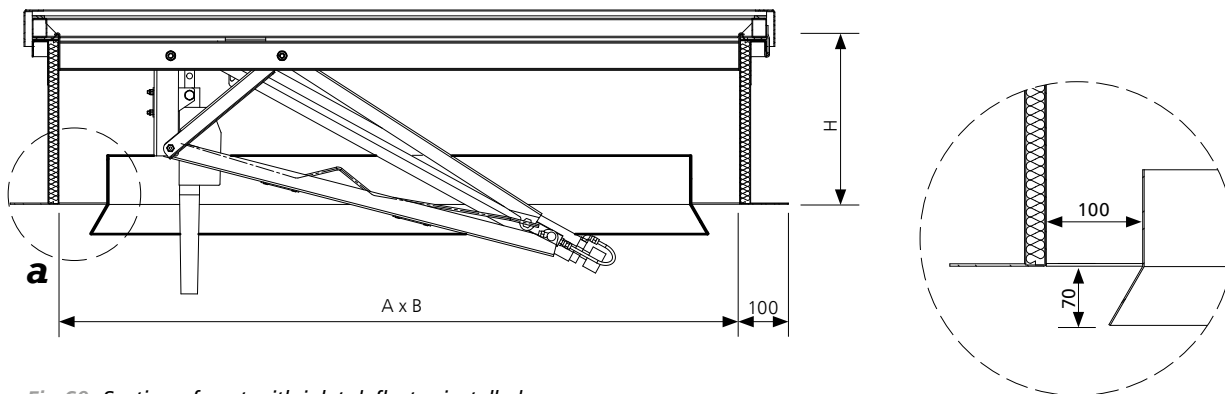

Fig.60 Section of vent with inlet deflector installed

Detail **a** dimensions in [mm]

5.4 | Anti-burglar grid

- » application in vents within the full dimensional range, and in skylight and hatches,
- » prevents from access of unauthorized persons, and from falling inside,
- » conforms to class 2 anti-burglar resistance as per ENV 1627:2009,
- » resistant to impact of large, soft body, up to maximum energy of 1200J - corresponds to SB1200 class as per EN 1873:2009 standard,
- » made of 21 mm galvanized steel rods fixed in steel sections; the pipes rotate, preventing from sawing off,
- » rods additionally stringed with cross-bar,
- » grid installed in the device base,
- » maximum distance between rods of the grid - 180 mm,
- » powder painted or galvanized grid.



Fig.61 Anti-burglar grid installed in mcr PROLIGHT E type vent

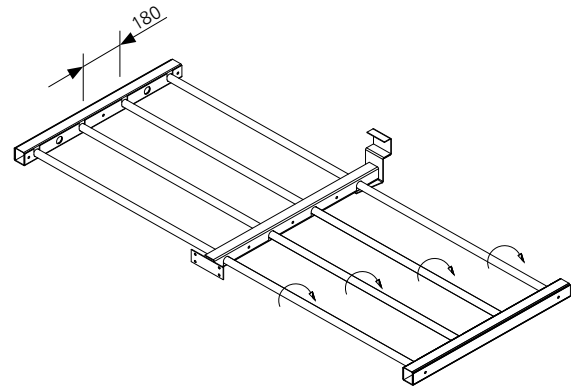

Fig.62 Anti-burglar grid for smoke vent

5.5 | Safety net

- » application in vents within the full dimensional range,
- » prevents from falling through,
- » resistant to impact of large, soft body, up to maximum energy of 1200 J- corresponds to SB1200 class as per EN 1873:2009 standard,
- » net installed in the device base,
- » made of galvanized steel rods of 4÷8 mm diameter, grid length depends on vent size,
- » net non-standard options:
 - powder coating,
 - openable net for mcr Prolight smoke vents with roof access function and hatches,
- » optional safety (safeguard) net manufacturing, in accordance with EN 1263-1, providing fall protection. The net is made of polypropylene ropes and installed in the vent base.



Fig.63 Safety net installed in mcr PROLIGHT C type vent

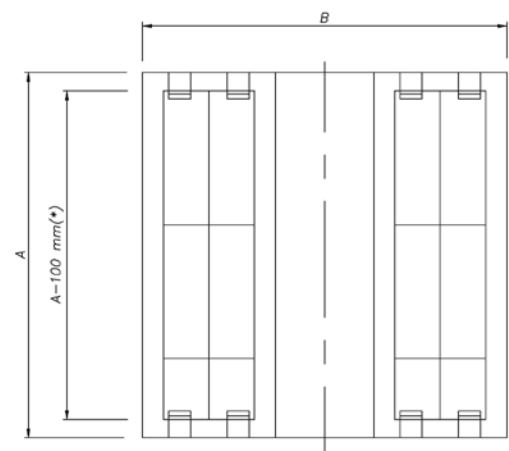

Fig.64 Top view of vent with safety net

A, B – nominal smoke vent dimensions [mm]

5.6 | Overlay type base - N type

- » possible to apply in mcr Prolight C, E, DVP type vent,
- » vents with N type base are designed for placement on reinforced concrete or steel plinths,
- » flange allowing mounting on a plinth,
- » the base flange dimensions are adapted to the size of existing plinth, according to client specifications,
- » external flashing of the base with flange is made of galvanized steel sheet.

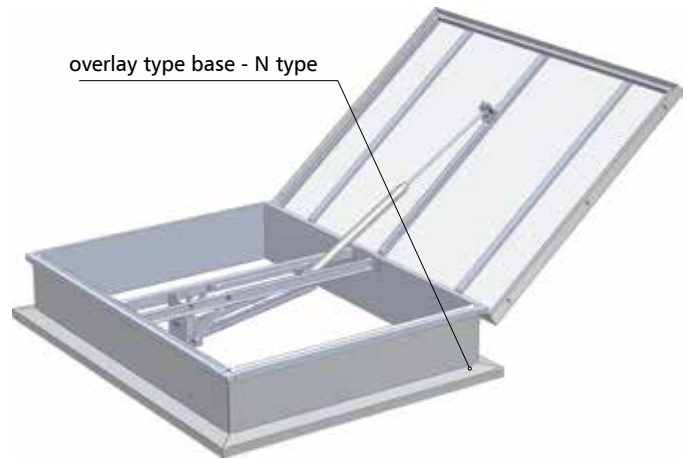

Fig.65 mcr PROLIGHT E type smoke vent with N type base

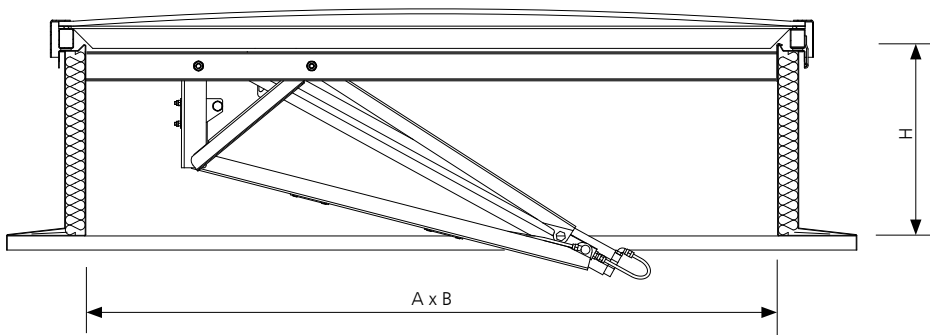
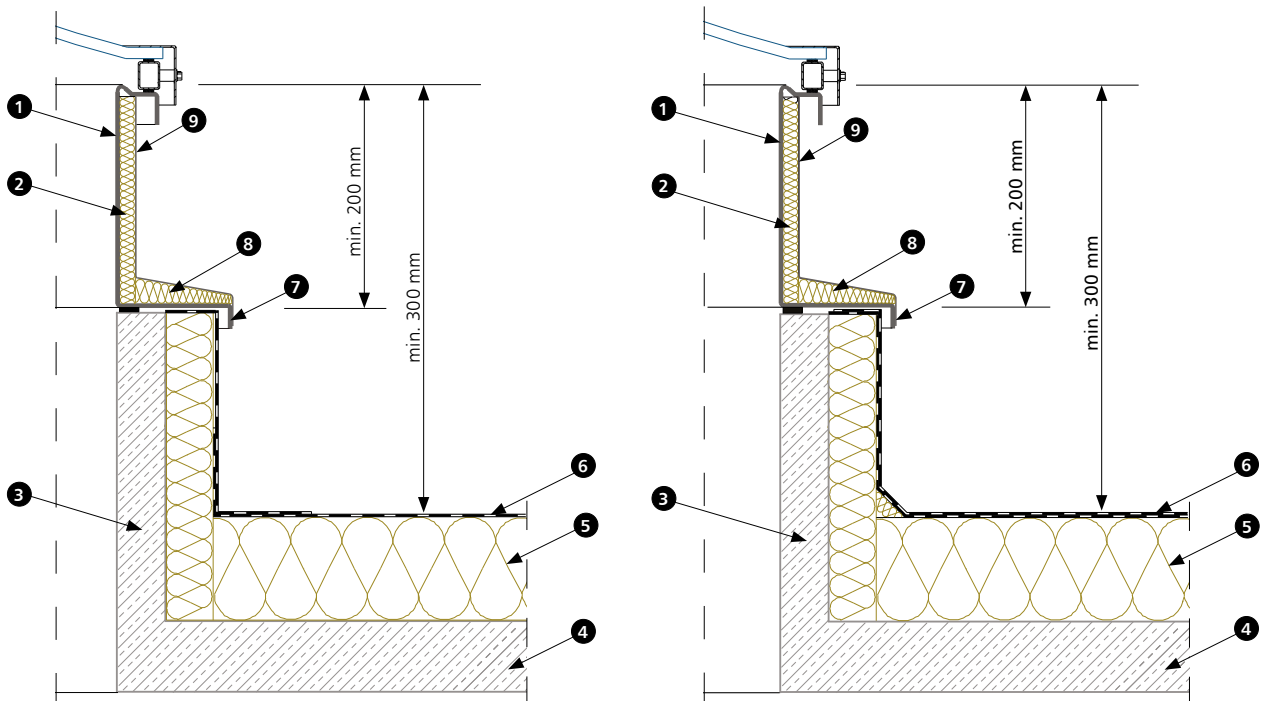

Fig.66 Section of mcr PROLIGHT E type vent with N plinth type base



1. smoke vent steel base
2. thermal insulation of base
3. reinforced concrete plinth(*)
4. ceiling, e.g. reinforced concrete slab
5. thermal insulation of roof
6. PVC membrane
7. drip cap
8. thermal insulation of flange
9. galvanized steel sheet

(*) wooden or steel plinth

1. smoke vent steel base
2. thermal insulation of base
3. reinforced concrete plinth(*)
4. ceiling, e.g. reinforced concrete slab
5. thermal insulation of roof
6. roofing paper
7. drip cap
8. thermal insulation of cover plate
9. galvanized steel sheet

5.7 | Limit switch

- » indicates the position of smoke vent or ventilation vent leaf, displaying the position status on a control panel, or gives signal to fire signalling system,
- » three position status indications are possible:
 - full closed position
 - full open position,
 - any open position,
- » includes 1xNO and 1xNC voltage-free contacts,
- » nominal voltage range up to 250 V- or up to 400 V~,
- » maximum current-carrying capacity of contacts 10A (resistance load), dependent on load characteristics,
- » switching frequency 3 600 cycles/hour,
- » operating temperature range -25°C ÷ 70°C,
- » switch casing protection rating IP65.

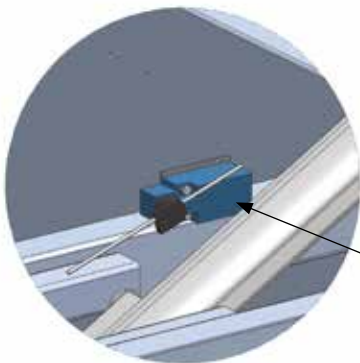

Fig.67 Limit switch in mcr PROLIGHT E type smoke vent

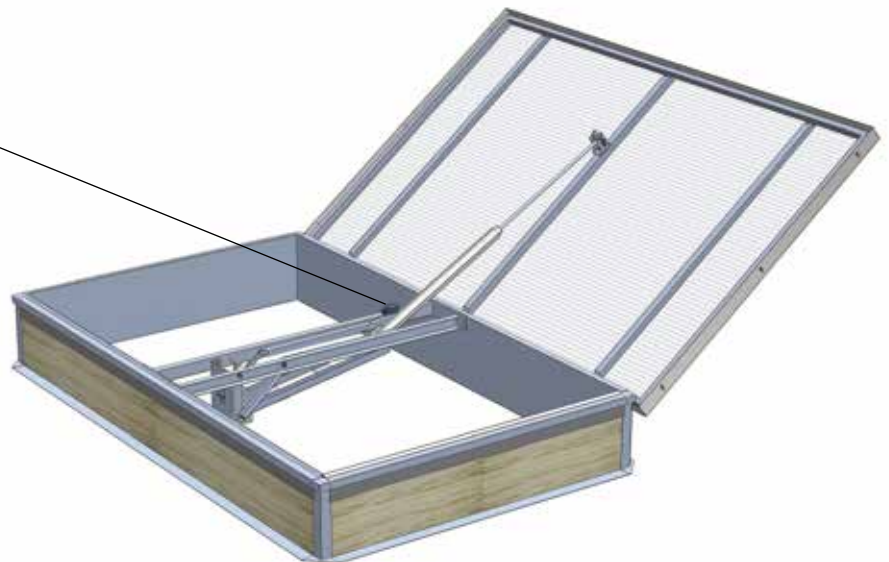

Fig 68 mcr PROLIGHT E type smoke vent with limit switch

5.8 | Mechanic opening system

Mechanic opening system relies on using gas springs (oleopneumatic actuators) in smoke exhaust vents. Actuation of smoke vents is effected by the energy of gas compressed in the gas spring. The vent is kept closed by a mechanical lock with thermal fuse. When the temperature rises above a certain level, the lock opens and the actuators expands, causing the opening of the vent. With adequate lock design (use of electromagnet), the system may be opened remotely by an electric signal (24 V-), which permits e.g. integration with central control panel for smoke exhaust and fire alarm signalling systems.

		Single leaf vent with gas springs	Double leaf vent with gas springs
Certificate of conformity no. 1396-CPR-0040		●	●
Parameters in accordance with EN 12101-2		SL=350 WL= 750 Re=300 B=600 T=00(*)	SL=500 WL=1500 Re=100 B=600 T=00(*)
Ventilation		Windlass	-
Glazing	Multi-chamber polycar- bonate panel	●	●
	Acrylic dome	●	-
	Solid polycarbonate dome	●	-
	ALU sandwich panel(**)	●	●
	Classification B _{ROOF} (t1)	-	-
	Multi-chamber polycar- bonate panel and envelope cover(***)	●	●
	Multi-chamber polycar- bonate panel and single or double-layer acrylic dome or solid polycarbo- nate dome	-	-
Additional equipment	Pull cords for manual opening from inside and/ or outside	●	●
Available sizes		C type – 800 ÷ 1200 mm (from 800x800 mm to 1200x1200 mm) E type – 800/1000 mm ÷ 1000/1200 mm (from 800x1000 mm to 1000x1200 mm) INTERMEDIATE SIZES ALLOWED	C type – 1000 ÷ 1000 mm (from 1000x1000 mm to 1400x1400 mm) E type – 1000/1100 mm ÷ 1000/2000 mm (from 1000x1100 mm to 1000x2000 mm) INTERMEDIATE SIZES ALLOWED
			DVP 1000x1800 mm DVP 1000x2000 mm DVP 1200x1800 mm DVP 1200x2000 mm DVP 1200x2400 mm NO INTERMEDIATE SIZES ALLOWED

*) (-5) available if SL reduced by 5%
 (**) ALU sandwich panel: aluminium-thermal insulation-aluminium
 (***) Applies to selected vent sizes

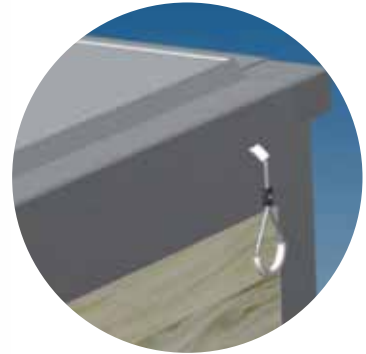

Detail a – pull cord

Fig.69 Design of mcr PROLIGHT Csmoke vent equipped in mechanic control system

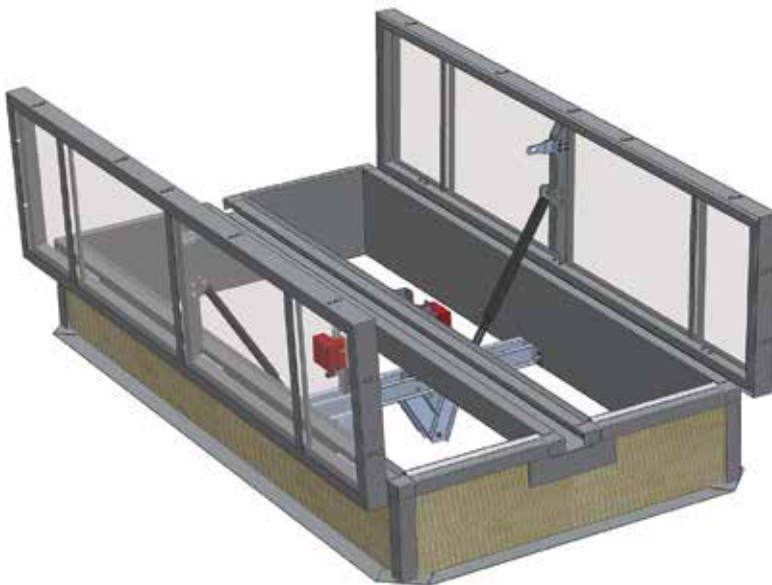





Fig.70 Design of mcr PROLIGHT DVP smoke vent equipped in mechanic control system

6. | Continuous rooflights with smoke vents and/or ventilation vents

Continuous rooflights are the most effective method of increasing natural light intensity in rooms. Their application in large-area single-storey buildings allows lighting even of the entire building area.

	Arch shaped rooflights	Triangular shaped rooflights	Pyramid skylights	Igloo skylights
Parameters				
Classification	Certificate of Conformity in accordance EN14963: » DL1000 / DL1125 / DL1500 / DL 2000 / DL 2050 / DL 2500 – resistance to downward loads as per EN 14963, dependent on glazing thickness » UL 1000/ UL 1500 – resistance to pull-off loads as per EN 14963, dependent on glazing thickness » Resistance of glazing to hard body impact as per EN 14963 » Resistance of glazing to large soft body impact as per EN 14963 for SB300 class » Fire performance for external fire, class B _{ROOF} (t1) as per EN 13501-5			
Skylight span / diameter	1,2 ≤ S ≤ 6,0 m	1,2 ≤ S ≤ 5,0 m	1,2 ≤ S ≤ 5,0 m	1,2 ≤ D ≤ 6,0 m
Geometry	Skylight geometry is dependent on the thickness of polycarbonate (PCA):			Skylight inclination angle: » 30° < α < 60°, » optimum α = 45° Dome base shape: » regular polygon inscribed into a circle of diameter D
	glazing thickness (PCA)	bending radius [mm]	min. skylight span	
	g	R	S _{min}	
	10 mm	1750, 2050, 2800	1,2 m	
	16 mm	2800, 3250, 4500	1,5 m	
20 mm	3600, 4500	2,0 m		
25 mm	4500	2,5 m		
Module length	m ₁ = 710 mm or m ₂ = 1060 mm			
Glazing	» multi-chamber polycarbonate panel (PCA) of th. 10 mm, 16 mm, 20 mm, 25 mm » B _{ROOF} (t1) classification – multi-chamber polycarbonate panel, as above + polyester panel » multiple glazing with multi-chamber polycarbonate, see Section 8 for details			
Smoke vents	-			
Ventilation vents	» single-leaf vents 100x100 cm ÷ 200x250 cm » double-leaf vents 100x100 cm ÷ 250x250 cm	» single-leaf vents 100x100 cm ÷ 200x250 cm » double-leaf vents 100x100 cm ÷ 250x250 cm	» single-leaf vents 100x100 cm ÷ 200x250 cm	-
Smoke vent classification	Certificate of Constancy of Performance 1396-CPR -0039 as per EN12101-2:2003 (EN12101-2:2005): » WL750 lub WL 1500 – operational certainty of vents under wind stress of 750 Pa or 1500 Pa » T(-25) – resistance of vents to low temperature of - 25 °C » B300 – resistance of vents to high temperature of 300°C, » SL – operational certainty of vents under snow load N/m ² » Re50 – operational reliability of single leaf during 50 cycles of opening and closing to smoke exhaust position, and 10 000 cycles to ventilation position (double function vent), » Re50 and Re300 – operational reliability of double-leaf vent during 50 cycles of opening and closing to smoke exhaust position, and 10 000 cycles to ventilation position (double function vent),			
Vent control	» smoke exhaust - pneumatic, electric 24 V- » ventilation – electric 230 V~, electric 24 V-	» ventilation – electric 230 V~, electric 24 V-		-
Non-standard options	» alternative base sheet thickness of 2.5 mm – for self-supporting base of modular length up to 6.0 m » skylight elements painted to any RAL color » custom base height of h ≤ 300 mm » custom width of circumferential flange of base, » self-supporting base of modular length up to 6000 mm » custom base design » anti-burglar grid » safety nets » available in configuration with soft body impact resistance up to 1200 J			

6.1 | Arch shaped continuous rooflights

6.1.1 | Technical description of standard

- » pcontinuous rooflights in accordance with EN 14963,
- » straight base of height 300 mm ÷ 700 mm made of galvanized steel sheet of thickness adequate to the skylight parameters (width, length, glazing thickness),
- » dimensional range,
- » bottom part of base has a circumferential flange of standard width 70 mm, for installing on the roof structure,
- » skylight base stiffened with bracing at 1500 mm or 3000 mm,
- » continuous rooflight base adapted for installing thermal insulation of min. thickness 50 mm,
- » continuous rooflight structure made of aluminum profiles of shape ensuring water run-off,
- » skylights glazing made of multi-chamber polycarbonate, available in various thicknesses and colors, glazing with B_{ROOF}(t1) classification,
- » continuous rooflights may be delivered with openable vents,
 - smoke vents for exhausting smoke, heat and burning fumes,
 - ventilation vents for daily ventilation.

6.1.2 | Arch shaped continuous rooflight design

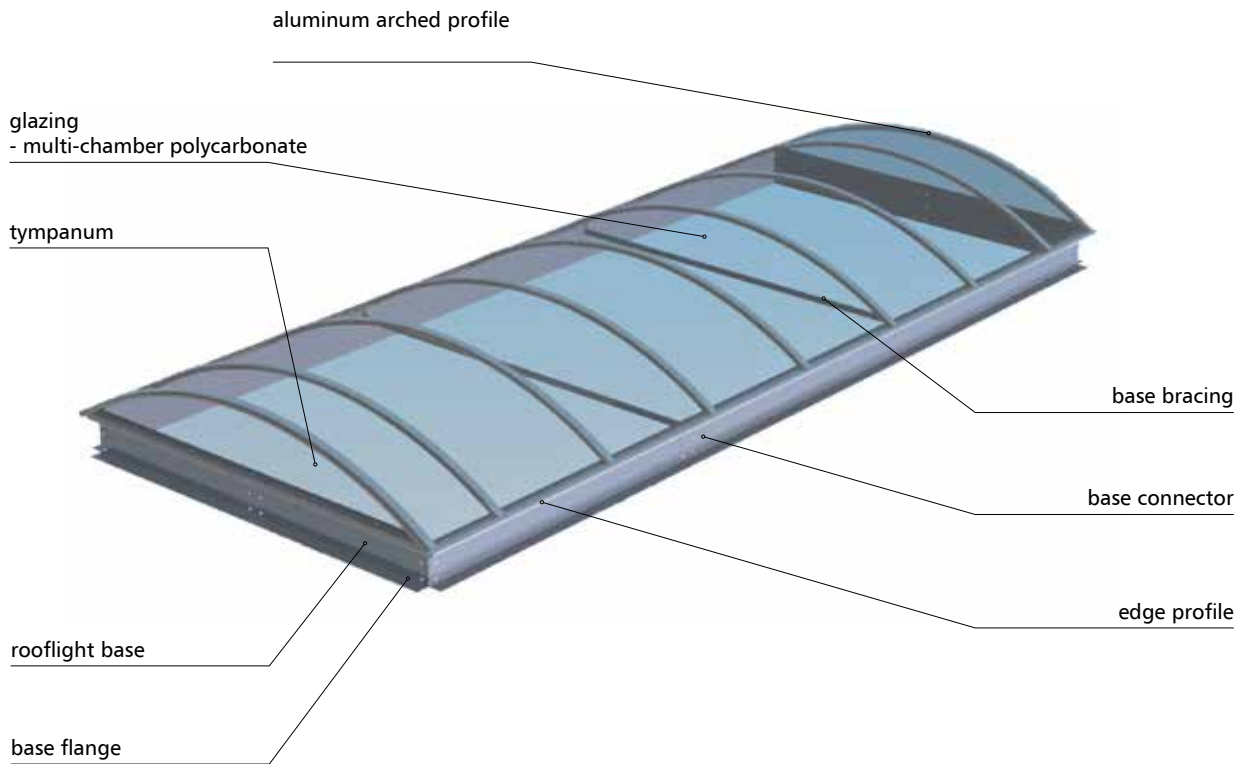

Fig.71 Design of mcr PROLIGHT arch shaped continuous rooflight

6.1.3 | Technical drawings of arch shaped continuous rooflight

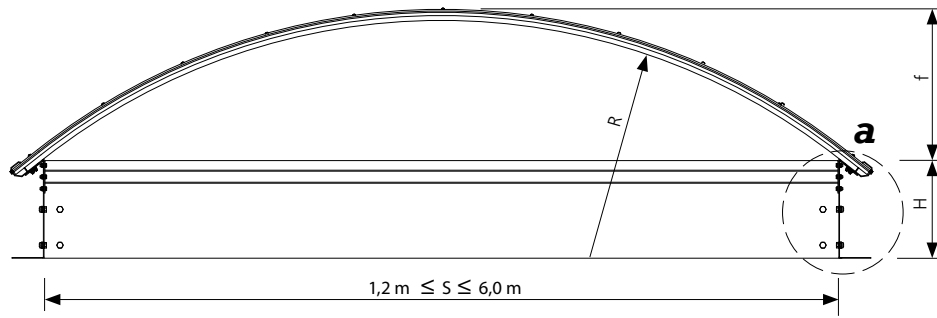

Fig.72 Cross section **A-A** of mcr PROLIGHT arch shaped continuous rooflight

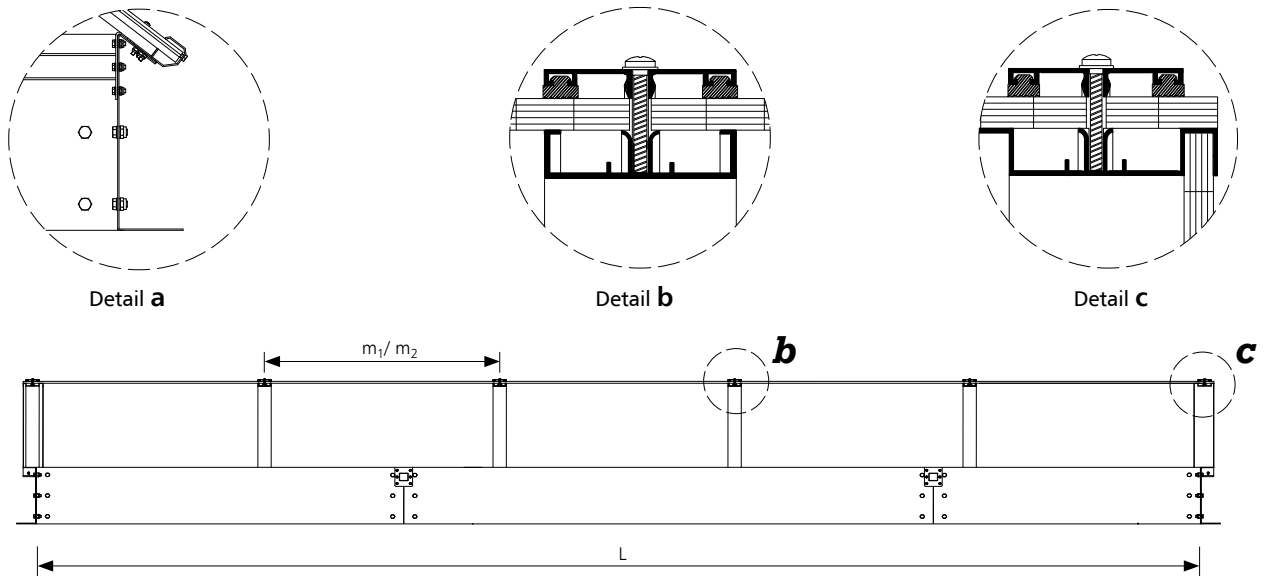

Fig.73 Cross section **B-B** of mcr PROLIGHT arch shaped continuous rooflight

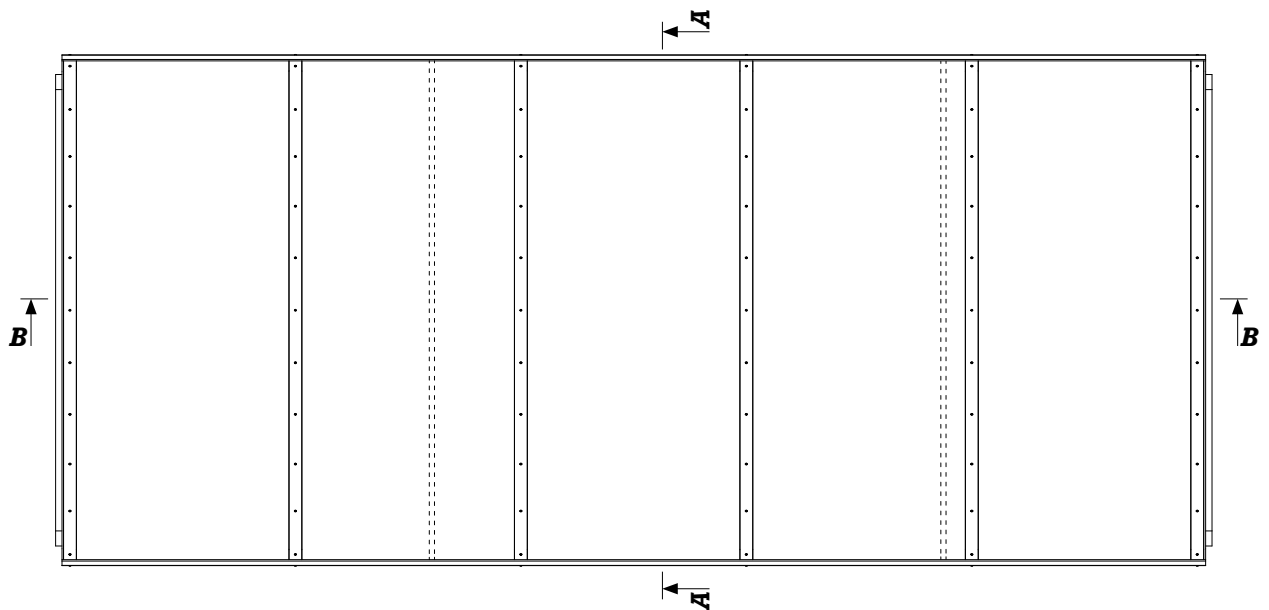

Fig.74 Top view of mcr PROLIGHT continuous rooflight

- S – continuous rooflight span [m]
- L – skylight length [m]
- R – continuous rooflight radius [mm]
- f – continuous rooflight rise [mm] – depends on glazing thickness, bending radius and rooflight span
- H – continuous rooflight base height [mm]
- m_1/m_2 – modular spacing of bearing and pressing sections available in two sizes: 710 mm or 1060 mm

6.2 | Smoke vents integrated in arch shaped continuous rooflights

6.2.1 | Technical description of standard

- » continuous rooflights may be delivered with openable vents:
 - smoke vents for exhausting smoke, heat and burning fumes,
 - ventilation vents for daily ventilation
- » smoke vent leaf opening angle:
 - $\geq 140^\circ$ for single-leaf vent
 - $\geq 90^\circ$ for double-leaf vent
- » smoke exhaust control: pneumatic, electric 24 V-,
- » ventilation control: electric 230 V~.

6.2.2 | Arch shaped continuous rooflight design with integrated smoke vents

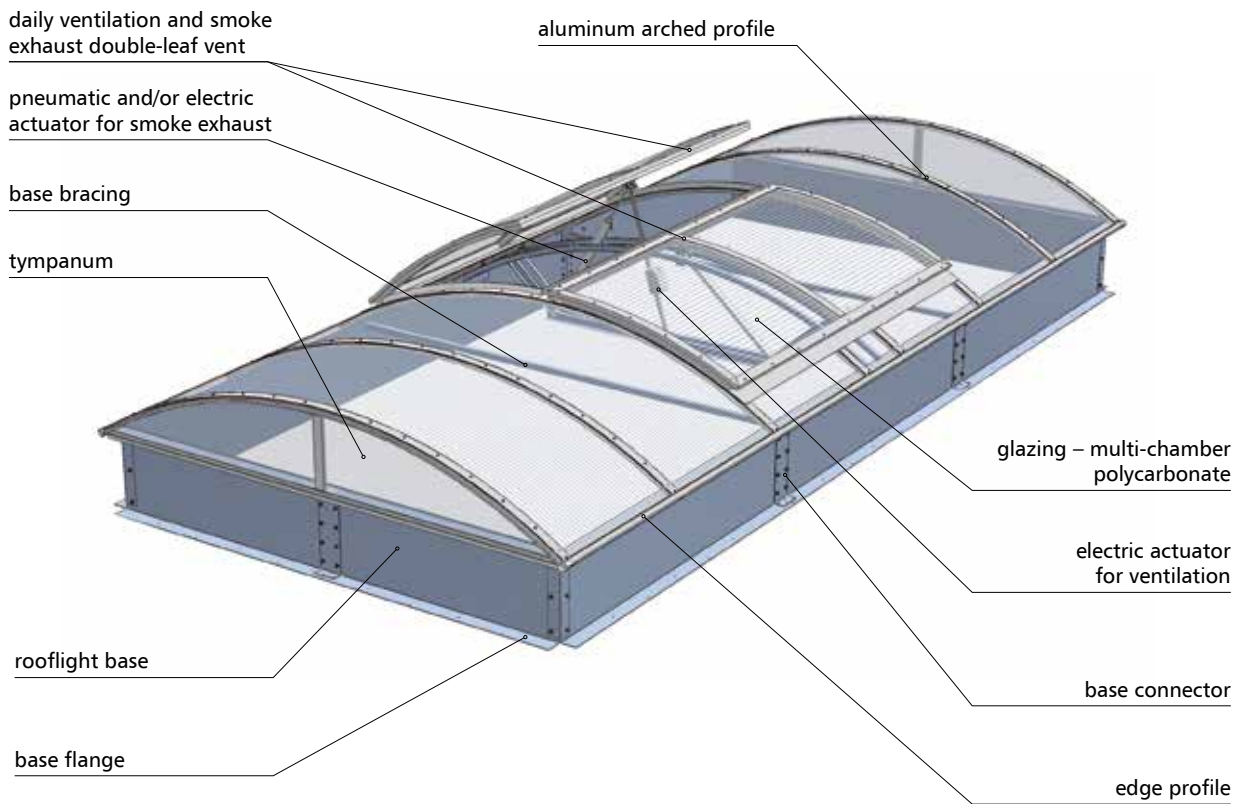

Fig.75 Design of mcr PROLIGHT arch shaped continuous rooflight with double-leaf smoke vent, with pneumatic actuator for smoke exhaust and electric actuator for daily ventilation

6.2.3 | Technical drawings of sample configurations of continuous rooflights with integrated smoke vents

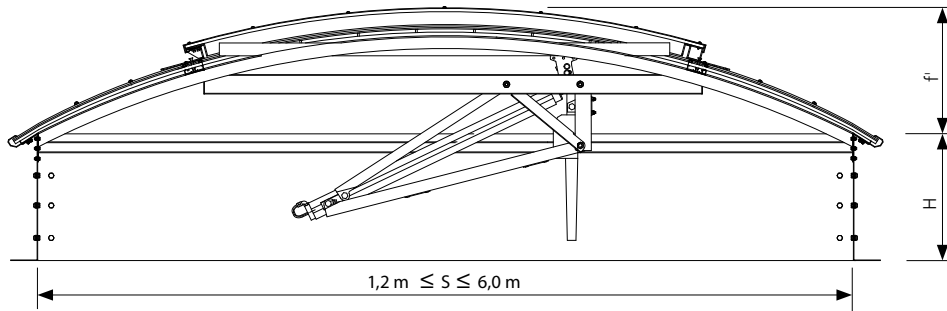

Fig.76 Cross section **C-C** of mcr PROLIGHT arch shaped continuous rooflight with integrated smoke exhaust and daily ventilation single-leaf vent

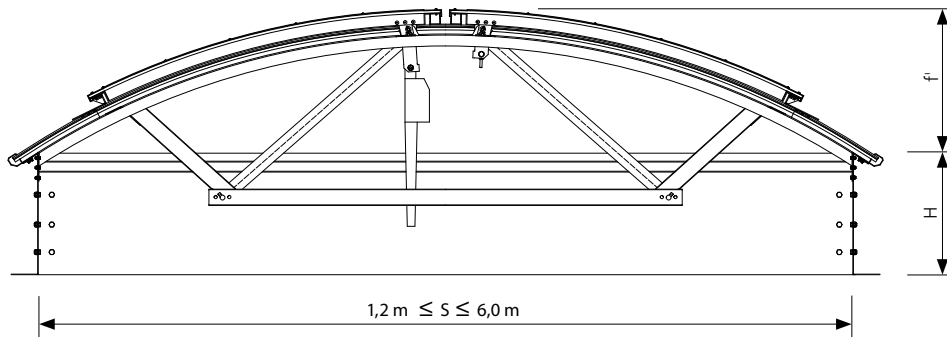

Fig.77 Cross section **D-D** of mcr PROLIGHT arch shaped continuous rooflight with integrated smoke exhaust and daily ventilation double-leaf vent

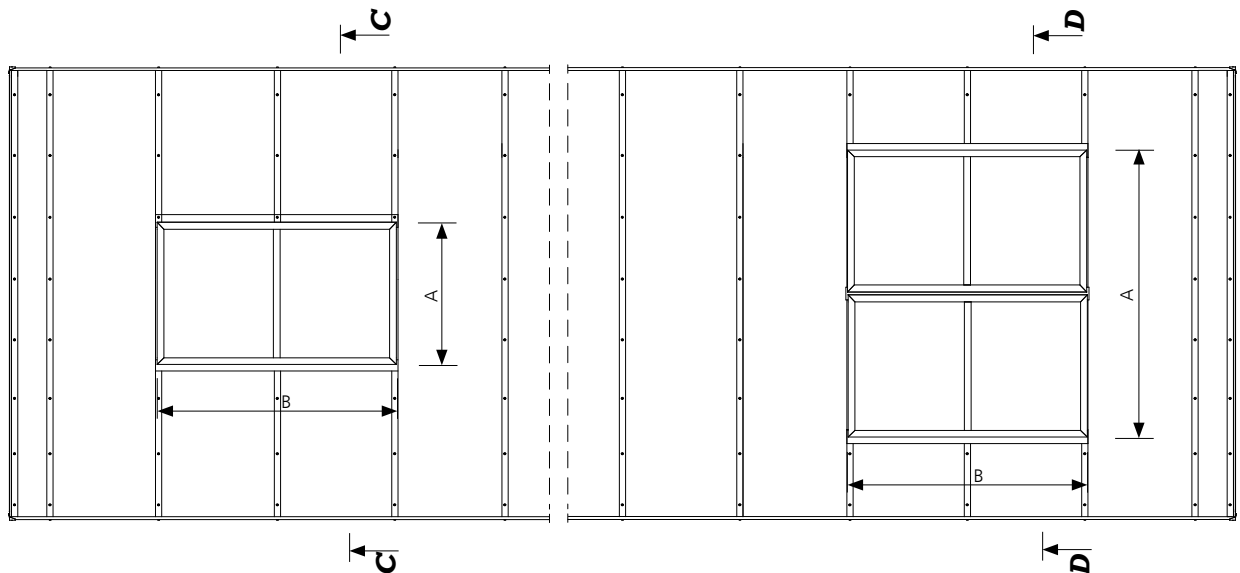

Fig.78 Top view of mcr PROLIGHT arch shaped continuous rooflight with integrated smoke exhaust and daily ventilation single and double-leaf vent

S – continuous rooflight span [m]
 f – continuous rooflight rise [mm] – depends on glazing thickness, bending radius and rooflight span
 H – continuous rooflight base height [mm]
 A, B – nominal vent dimensions

6.2.4 | Available sizes table for smoke vents in arch shaped continuous rooflights as per CE 1396-CPR-0039

NOMINAL DIMENSIONS [A x B]	ACTIVE AREA A_a [m ²]			
	SINGLE-LEAF VENTS		DOUBLE-LEAF VENTS	
[mm]	WITHOUT WIND DEFLECTORS	WITH WIND DEFLECTORS	WITHOUT WIND DEFLECTORS	WITH WIND DEFLECTORS
1000 x 1000	0,44	0,72	0,42	0,66
1000 x 1100	0,47	0,8	0,46	0,73
1000 x 1200	0,51	0,87	0,5	0,81
1000 x 1300	0,54	0,95	0,54	0,88
1000 x 1400	0,57	1,02	0,58	0,95
1000 x 1500	0,6	1,09	0,62	1,03
1000 x 1600	0,63	1,17	0,67	1,1
1000 x 1700	0,66	1,24	0,71	1,17
1000 x 1800	0,68	1,32	0,76	1,25
1000 x 1900	0,71	1,39	0,8	1,32
1000 x 2000	0,73	1,46	0,85	1,39
1000 x 2100	0,75	1,54	0,9	1,47
1000 x 2200	0,77	1,61	0,95	1,54
1000 x 2300	0,79	1,68	1,0	1,61
1000 x 2400	0,81	1,76	1,05	1,69
1000 x 2500	0,83	1,83	1,1	1,76
1100 x 1000	0,48	0,8	0,45	0,73
1100 x 1100	0,52	0,88	0,49	0,82
1100 x 1200	0,56	0,96	0,53	0,9
1100 x 1300	0,6	1,04	0,57	0,98
1100 x 1400	0,63	1,12	0,62	1,06
1100 x 1500	0,67	1,2	0,66	1,14
1100 x 1600	0,7	1,29	0,71	1,22
1100 x 1700	0,73	1,37	0,76	1,3
1100 x 1800	0,76	1,45	0,8	1,38
1100 x 1900	0,79	1,53	0,85	1,47
1100 x 2000	0,82	1,61	0,9	1,55
1100 x 2100	0,84	1,69	0,95	1,63
1100 x 2200	0,87	1,78	1,0	1,71
1100 x 2300	0,89	1,86	1,05	1,79
1100 x 2400	0,91	1,94	1,11	1,87
1100 x 2500	0,93	2,02	1,16	1,95
1200 x 1000	0,52	0,87	0,48	0,81
1200 x 1100	0,57	0,96	0,52	0,9
1200 x 1200	0,61	1,05	0,56	0,99
1200 x 1300	0,65	1,14	0,61	1,08
1200 x 1400	0,69	1,23	0,66	1,16
1200 x 1500	0,73	1,32	0,7	1,25
1200 x 1600	0,77	1,41	0,75	1,34
1200 x 1700	0,8	1,49	0,8	1,43
1200 x 1800	0,84	1,58	0,85	1,52
1200 x 1900	0,87	1,67	0,9	1,61
1200 x 2000	0,9	1,76	0,95	1,7
1200 x 2100	0,93	1,85	1,0	1,79
1200 x 2200	0,96	1,94	1,06	1,88
1200 x 2300	0,99	2,03	1,11	1,97
1200 x 2400	1,01	2,12	1,17	2,06
1200 x 2500	1,04	2,21	1,22	2,15
1300 x 1000	0,56	0,95	0,51	0,88
1300 x 1100	0,61	1,04	0,55	0,98
1300 x 1200	0,66	1,14	0,6	1,08
1300 x 1300	0,7	1,24	0,65	1,17

NOMINAL DIMENSIONS [A x B]	ACTIVE AREA A_a [m ²]			
	SINGLE-LEAF VENTS		DOUBLE-LEAF VENTS	
	WITHOUT WIND DEFLECTORS	WITH WIND DEFLECTORS	WITHOUT WIND DEFLECTORS	WITH WIND DEFLECTORS
[mm]				
1300 x 1400	0,75	1,33	0,69	1,27
1300 x 1500	0,79	1,43	0,74	1,37
1300 x 1600	0,83	1,53	0,79	1,46
1300 x 1700	0,87	1,62	0,84	1,56
1300 x 1800	0,91	1,72	0,9	1,66
1300 x 1900	0,95	1,82	0,95	1,76
1300 x 2000	0,98	1,91	1,0	1,85
1300 x 2100	1,02	2,01	1,06	1,95
1300 x 2200	1,05	2,11	1,11	2,05
1300 x 2300	1,08	2,2	1,17	2,15
1300 x 2400	1,11	2,3	1,23	2,24
1300 x 2500	1,14	2,4	1,29	2,34
1400 x 1000	0,6	1,02	0,54	0,95
1400 x 1100	0,66	1,12	0,58	1,06
1400 x 1200	0,71	1,23	0,63	1,16
1400 x 1300	0,76	1,33	0,68	1,27
1400 x 1400	0,81	1,44	0,73	1,38
1400 x 1500	0,85	1,54	0,78	1,48
1400 x 1600	0,9	1,64	0,84	1,59
1400 x 1700	0,94	1,75	0,89	1,69
1400 x 1800	0,99	1,85	0,94	1,8
1400 x 1900	1,03	1,96	1,0	1,9
1400 x 2000	1,07	2,06	1,05	2,01
1400 x 2100	1,11	2,17	1,11	2,11
1400 x 2200	1,14	2,27	1,17	2,22
1400 x 2300	1,18	2,37	1,23	2,32
1400 x 2400	1,21	2,48	1,29	2,43
1400 x 2500	1,25	2,58	1,35	2,53
1500 x 1000	0,65	1,09	0,57	1,03
1500 x 1100	0,7	1,2	0,62	1,14
1500 x 1200	0,76	1,32	0,67	1,25
1500 x 1300	0,81	1,43	0,72	1,37
1500 x 1400	0,86	1,54	0,77	1,48
1500 x 1500	0,92	1,65	0,82	1,59
1500 x 1600	0,97	1,76	0,88	1,71
1500 x 1700	1,01	1,88	0,93	1,82
1500 x 1800	1,06	1,99	0,99	1,93
1500 x 1900	1,11	2,1	1,05	2,05
1500 x 2000	1,15	2,21	1,11	2,16
1500 x 2100	1,19	2,32	1,16	2,27
1500 x 2200	1,23	2,43	1,22	2,39
1500 x 2300	1,27	2,55	1,29	2,5
1500 x 2400	1,31	2,66	1,35	2,61
1500 x 2500	1,35	2,77	1,41	2,73
1600 x 1000	0,69	1,17	0,6	1,1
1600 x 1100	0,75	1,29	0,65	1,22
1600 x 1200	0,81	1,41	0,7	1,34
1600 x 1300	0,86	1,53	0,75	1,46
1600 x 1400	0,92	1,64	0,81	1,59
1600 x 1500	0,98	1,76	0,86	1,71
1600 x 1600	1,03	1,88	0,92	1,83
1600 x 1700	1,08	2	0,98	1,95

NOMINAL DIMENSIONS [A x B]	ACTIVE AREA A_a [m ²]			
	SINGLE-LEAF VENTS		DOUBLE-LEAF VENTS	
[mm]	WITHOUT WIND DEFLECTORS	WITH WIND DEFLECTORS	WITHOUT WIND DEFLECTORS	WITH WIND DEFLECTORS
1600 x 1800	1,13	2,12	1,04	2,07
1600 x 1900	1,18	2,24	1,1	2,19
1600 x 2000	1,23	2,36	1,16	2,31
1600 x 2100	1,28	2,48	1,22	2,44
1600 x 2200	1,32	2,6	1,28	2,56
1600 x 2300	1,37	2,72	1,34	2,68
1600 x 2400	1,41	2,84	1,41	2,8
1600 x 2500	1,45	2,96	1,47	2,92
1700 x 1000	0,73	1,24	0,62	1,17
1700 x 1100	0,79	1,37	0,68	1,3
1700 x 1200	0,86	1,49	0,73	1,43
1700 x 1300	0,92	1,62	0,79	1,56
1700 x 1400	0,98	1,75	0,85	1,69
1700 x 1500	1,04	1,88	0,9	1,82
1700 x 1600	1,1	2	0,96	1,95
1700 x 1700	1,15	2,13	1,02	2,08
1700 x 1800	1,21	2,26	1,08	2,21
1700 x 1900	1,26	2,38	1,15	2,34
1700 x 2000	1,31	2,51	1,21	2,47
1700 x 2100	1,36	2,64	1,27	2,6
1700 x 2200	1,41	2,76	1,34	2,73
1700 x 2300	1,46	2,89	1,4	2,86
1700 x 2400	1,51	3,02	1,47	2,99
1700 x 2500	1,55	3,15	1,53	3,12
1800 x 1000	0,77	1,32	0,65	1,25
1800 x 1100	0,84	1,45	0,71	1,38
1800 x 1200	0,9	1,58	0,77	1,52
1800 x 1300	0,97	1,72	0,83	1,66
1800 x 1400	1,03	1,85	0,89	1,8
1800 x 1500	1,1	1,99	0,95	1,93
1800 x 1600	1,16	2,12	1,01	2,07
1800 x 1700	1,22	2,26	1,07	2,21
1800 x 1800	1,28	2,39	1,13	2,35
1800 x 1900	1,34	2,53	1,19	2,48
1800 x 2000	1,39	2,66	1,26	2,62
1800 x 2100	1,45	2,79	1,32	2,76
1800 x 2200	1,5	2,93	1,39	2,9
1800 x 2300	1,55	3,06	1,46	3,03
1800 x 2400	1,6	3,2	1,53	3,17
1800 x 2500	1,65	3,33	1,6	3,31
1900 x 1000	0,81	1,39	0,68	1,32
1900 x 1100	0,88	1,53	0,74	1,47
1900 x 1200	0,95	1,67	0,8	1,61
1900 x 1300	1,02	1,82	0,86	1,76
1900 x 1400	1,09	1,96	0,92	1,9
1900 x 1500	1,16	2,1	0,99	2,05
1900 x 1600	1,22	2,24	1,05	2,19
1900 x 1700	1,29	2,38	1,11	2,34
1900 x 1800	1,35	2,53	1,18	2,48
1900 x 1900	1,41	2,67	1,24	2,63
1900 x 2000	1,47	2,81	1,31	2,78

NOMINAL DIMENSIONS [A x B]	ACTIVE AREA A_a [m ²]			
	SINGLE-LEAF VENTS		DOUBLE-LEAF VENTS	
[mm]	WITHOUT WIND DEFLECTORS	WITH WIND DEFLECTORS	WITHOUT WIND DEFLECTORS	WITH WIND DEFLECTORS
1900 x 2100	1,53	2,95	1,38	2,92
1900 x 2200	1,59	3,09	1,45	3,07
1900 x 2300	1,65	3,24	1,52	3,21
1900 x 2400	1,7	3,38	1,59	3,36
1900 x 2500	1,75	3,52	1,66	3,5
2000 x 1000	0,85	1,46	0,71	1,39
2000 x 1100	0,92	1,61	0,77	1,55
2000 x 1200	1	1,76	0,84	1,7
2000 x 1300	1,07	1,91	0,9	1,85
2000 x 1400	1,15	2,06	0,96	2,01
2000 x 1500	1,22	2,21	1,03	2,16
2000 x 1600	1,29	2,36	1,09	2,31
2000 x 1700	1,36	2,51	1,16	2,47
2000 x 1800	1,42	2,66	1,22	2,62
2000 x 1900	1,49	2,81	1,29	2,78
2000 x 2000	1,55	2,96	1,36	2,93
2000 x 2100	1,62	3,11	1,43	3,08
2000 x 2200	1,68	3,26	1,5	3,24
2000 x 2300	1,74	3,41	1,57	3,39
2000 x 2400	1,8	3,56	1,65	3,54
2000 x 2500	1,85	3,71	1,72	3,7
2100 x 1000	-	-	0,74	1,47
2100 x 1100	-	-	0,81	1,63
2100 x 1200	-	-	0,87	1,79
2100 x 1300	-	-	0,93	1,95
2100 x 1400	-	-	1,0	2,11
2100 x 1500	-	-	1,07	2,27
2100 x 1600	-	-	1,13	2,44
2100 x 1700	-	-	1,2	2,6
2100 x 1800	-	-	1,27	2,76
2100 x 1900	-	-	1,34	2,92
2100 x 2000	-	-	1,41	3,08
2100 x 2100	-	-	1,49	3,24
2100 x 2200	-	-	1,56	3,41
2100 x 2300	-	-	1,63	3,57
2100 x 2400	-	-	1,71	3,73
2100 x 2500	-	-	1,78	3,89
2200 x 1000	0,93	1,61	0,77	1,54
2200 x 1100	-	-	0,84	1,71
2200 x 1200	-	-	0,9	1,88
2200 x 1300	-	-	0,97	2,05
2200 x 1400	-	-	1,04	2,22
2200 x 1500	-	-	1,11	2,39
2200 x 1600	-	-	1,18	2,56
2200 x 1700	-	-	1,25	2,73
2200 x 1800	-	-	1,32	2,9
2200 x 1900	-	-	1,39	3,07
2200 x 2000	-	-	1,46	3,24
2200 x 2100	-	-	1,54	3,41
2200 x 2200	-	-	1,61	3,58
2200 x 2300	-	-	1,69	3,75

NOMINAL DIMENSIONS [A x B]	ACTIVE AREA A_a [m ²]			
	SINGLE-LEAF VENTS		DOUBLE-LEAF VENTS	
[mm]	WITHOUT WIND DEFLECTORS	WITH WIND DEFLECTORS	WITHOUT WIND DEFLECTORS	WITH WIND DEFLECTORS
2200 x 2400	-	-	1,77	3,91
2200 x 2500	-	-	1,84	4,08
2300 x 1000	-	-	0,8	1,61
2300 x 1100	-	-	0,87	1,79
2300 x 1200	-	-	0,94	1,97
2300 x 1300	-	-	1,01	2,15
2300 x 1400	-	-	1,08	2,32
2300 x 1500	-	-	1,15	2,5
2300 x 1600	-	-	1,22	2,68
2300 x 1700	-	-	1,29	2,86
2300 x 1800	-	-	1,37	3,03
2300 x 1900	-	-	1,44	3,21
2300 x 2000	-	-	1,52	3,39
2300 x 2100	-	-	1,59	3,57
2300 x 2200	-	-	1,67	3,75
2300 x 2300	-	-	1,75	3,92
2300 x 2400	-	-	1,83	4,1
2300 x 2500	-	-	1,91	4,28
2400 x 1000	-	-	0,83	1,69
2400 x 1100	-	-	0,9	1,87
2400 x 1200	-	-	0,97	2,06
2400 x 1300	-	-	1,04	2,24
2400 x 1400	-	-	1,11	2,43
2400 x 1500	-	-	1,19	2,61
2400 x 1600	-	-	1,26	2,8
2400 x 1700	-	-	1,34	2,99
2400 x 1800	-	-	1,41	3,17
2400 x 1900	-	-	1,49	3,36
2400 x 2000	-	-	1,57	3,54
2400 x 2100	-	-	1,65	3,73
2400 x 2200	-	-	1,72	3,91
2400 x 2300	-	-	1,81	4,1
2400 x 2400	-	-	1,89	4,29
2400 x 2500	-	-	1,97	4,47
2500 x 1000	-	-	0,86	1,76
2500 x 1100	-	-	0,93	1,95
2500 x 1200	-	-	1,0	2,15
2500 x 1300	-	-	1,08	2,34
2500 x 1400	-	-	1,15	2,53
2500 x 1500	-	-	1,23	2,73
2500 x 1600	-	-	1,3	2,92
2500 x 1700	-	-	1,38	3,12
2500 x 1800	-	-	1,46	3,31
2500 x 1900	-	-	1,54	3,5
2500 x 2000	-	-	1,62	3,7
2500 x 2100	-	-	1,7	3,89
2500 x 2200	-	-	1,78	4,08
2500 x 2300	-	-	1,86	4,28
2500 x 2400	-	-	1,95	4,47
2500 x 2500	-	-	2,03	4,67

6.2.5 | Smoke vents control in arch shaped continuous rooflights as per CE 1396-CPR-0039

For correct operation, smoke vents as well as smoke exhaust & ventilation vents require devices controlling their opening and closing. A set of such devices constitutes a system for smoke exhaust control or smoke exhaust and ventilation control. Depending on the type of devices used, it may be designed as a:

- » pneumatic smoke exhaust control system,
- » 24 V- electric smoke exhaust control system with ventilation function,
- » pneumatic and electric control system; the pneumatic part is responsible for smoke exhaust, while the 230 V~ electric part - for ventilation.

Smoke exhaust control systems are activated as follows:

1. automatic – through a thermo switch installed in the vent (pneumatic system), or by optical smoke sensors (electric system),
2. manual – by a release of CO₂ cartridges in alarm box (pneumatic system), or by operation of RPO emergency pushbutton (electric system),
3. FAS signal – by external impulse from fire alarm system (FAS) sent to an electromagnet installed in the alarm box (pneumatic system) or directly to smoke exhaust control unit (electric system).

SINGLE-LEAF VENTS IN ARCH SHAPED CONTINUOUS ROOFLIGHTS					
VENT DIMENSIONS(*)	PNEUMATIC CONTROL(**)			ELECTRIC CONTROL(**)	
	PNEUMATIC ACTUATOR		MIN. CAPACITY OF CO ₂ – CARTRIDGE – SL 950 [g]	POWER CONSUMPTION [A] BY ELECTRIC ACTUATOR FOR CLASS	
	STROKE [mm]	DIAMETER [mm]		SL 250	SL 550
1000 x 1000	550	50	40	1,6	2,0
1000 x 1200	550	50	40	1,6	2,6
1000 x 1400	550	50	40	1,6	2,6
1000 x 1600	550	50	40	2,0	4,0
1000 x 1800	550	50	40	2,0	4,0
1000 x 2000	550	50	40	2,0	4,0
1000 x 2200	550	50	40	2,6	4,0
1000 x 2500	550	50	40	2,6	6,0
1200 x 1000	550	50	40	2,0	4,0
1200 x 1200	550	50	40	2,0	4,0
1200 x 1600	550	50	40	2,6	6,0
1200 x 1800	550	50	40	2,6	6,0
1200 x 2100	550	50	55	4,0	6,0
1200 x 2500	550	50	55	4,0	6,0
1400 x 1000	750	50	40	2,6	4,0
1500 x 1500	750	50	55	4,0	6,0
1500 x 1800	750	50	55	4,0	8,0
1500 x 2100	750	50	80	6,0	8,0
1500 x 2500	750	50	80	6,0	-
1600 x 1000	750	50	40	2,6	6,0
1800 x 1000	1050	63	80	6,0	8,0
1800 x 1800	1050	63	120	6,0	-
1800 x 2100	1050	63	120	8,0	-
1800 x 2500	1050	63	120	8,0	-
2000 x 1000	1050	63	80	6,0	8,0
2000 x 2000	1050	63	120	8,0	-
2000 x 2100	1050	63	120	8,0	-
2000 x 2500	1050	63	120	-	-
2200 x 1000	1300	63	120(**)	-	-

(*) For different smoke vent dimensions than specified in the table control system should be selected for larger size of the vent.

(**) SL500

(***) - For selected sizes there are different SL options available:

- For electric control: SL750, SL950, SL1300 and SL1600

- For pneumatic control: SL250, SL750, SL1300, SL1600 and SL2000

DOUBLE-LEAF VENTS IN ARCH SHAPED CONTINUOUS ROOFLIGHTS					
VENT DIMENSIONS(*)	PNEUMATIC CONTROL(***)			ELECTRIC CONTROL(***)	
	PNEUMATIC ACTUATOR		MIN. CAPACITY OF CO ₂ – CARTRIDGE – SL 950 [g]	POWER CONSUMPTION [A] BY ELECTRIC ACTUATOR FOR CLASS	
	STROKE [mm]	DIAMETER [mm]		SL 250	SL 550
1000 x 1500	400	40	24	2 x 0,8	2 x 0,8
1000 x 2500	400	40	40	2 x 0,8	2 x 1,3
1200 x 1200	400	40	24	2 x 0,8	2 x 1,0
1200 x 1500	400	40	24	2 x 0,8	2 x 1,0
1200 x 2100	400	40	24	2 x 0,8	2 x 1,3
1500 x 1500	400	40	24	2 x 1,6	2 x 2,0
1500 x 2100	400	40	40	2 x 1,6	2 x 2,6
1500 x 2500	400	40	40	2 x 1,6	2 x 2,6
1800 x 2100	550	40	55	2 x 1,6	2 x 4,0
2000 x 2100	600	40	55	2 x 2,0	2 x 4,0
2000 x 2500	600	40	80	2 x 2,0	2 x 4,0
2200 x 2500	700	40	80	2 x 4,0	2 x 6,0
2400 x 2500	750	40	120	2 x 4,0	2 x 6,0
2500 x 2500	850	40	120(**)	2 x 4,0	2 x 8,0

(*) For different smoke vent dimensions than specified in the table control system should be selected for larger size of the vent.

(**) SL500

(***) - For selected sizes there are different SL options available:

- For electric control: SL750, SL950, SL1300 and SL1600

- For pneumatic control: SL250, SL750, SL1300, SL1600 and SL2000

6.3 | Triangular shaped continuous rooflights

6.3.1 | Technical description of standard

- » continuous rooflights in accordance with EN 14963,
- » width 1200 - 5000 mm,
- » straight base of height 300 mm ÷ 700 mm made of galvanized steel sheet of thickness adequate to the rooflight parameters (width, length, glazing thickness),
- » bottom part of base has a circumferential flange of standard width 70 mm, for installing on the roof structure,
- » skylight base hardened using bracing spaced at 1500 mm or 3000 mm,
- » continuous rooflight base adapted for installing thermal insulation of min. thickness 50 mm,
- » continuous rooflight structure made of aluminum profiles of shape ensuring water run-off,
- » continuous rooflights glazing made of multi-chamber polycarbonate, available in various thicknesses and colors,
- » continuous rooflights may be delivered with openable vents:
 - ventilation vents for daily ventilation of facilities,
- » ventilation control: electric 230 V~ / 24 V-.

6.3.2 | Triangular shaped continuous rooflight design

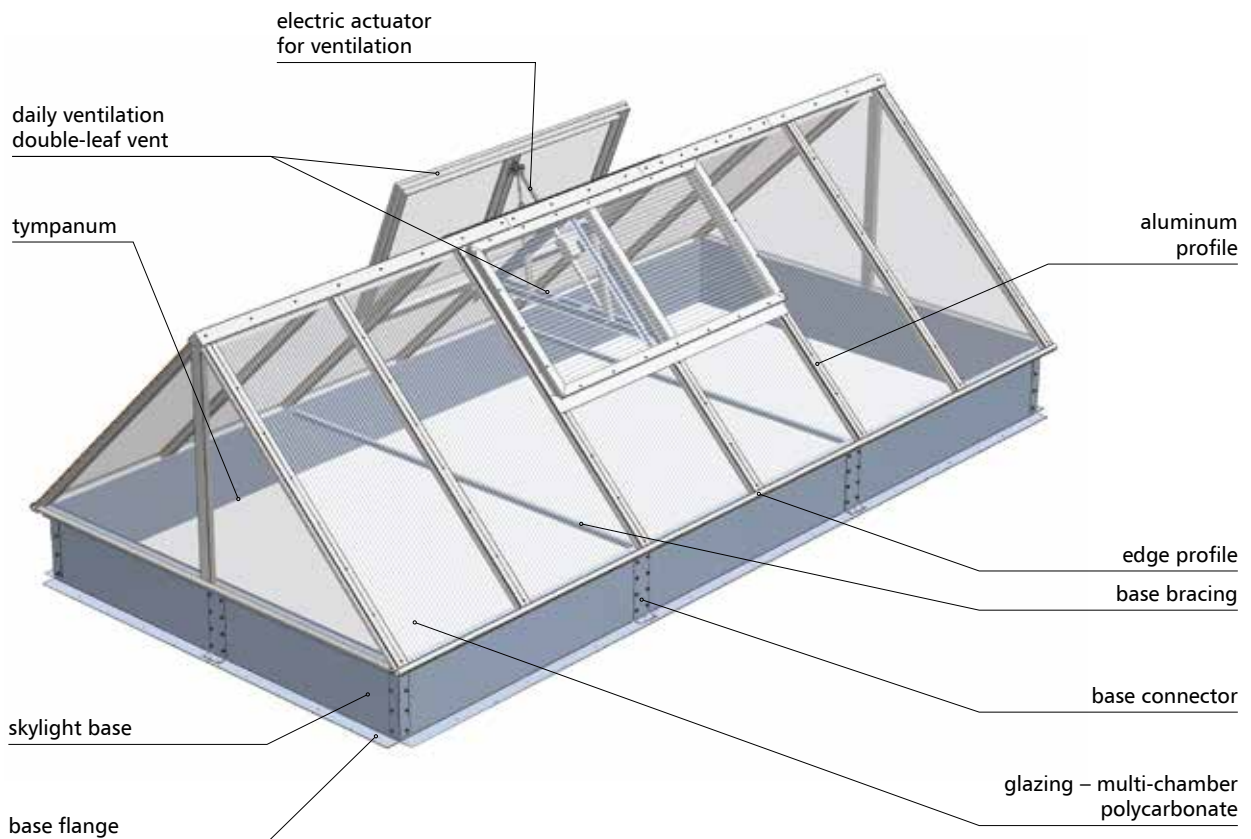

Fig. 79 Design of mcr PROLIGHT triangular shaped continuous rooflight with double-leaf vent, with electric actuator for daily ventilation

6.3.3 | Technical drawings of triangular shaped continuous rooflight

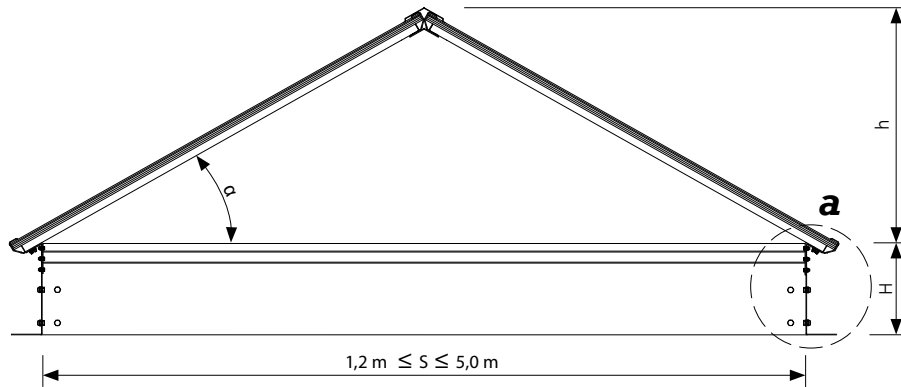

Fig.80 Cross section A-A of mcr PROLIGHT triangular shaped continuous rooflight

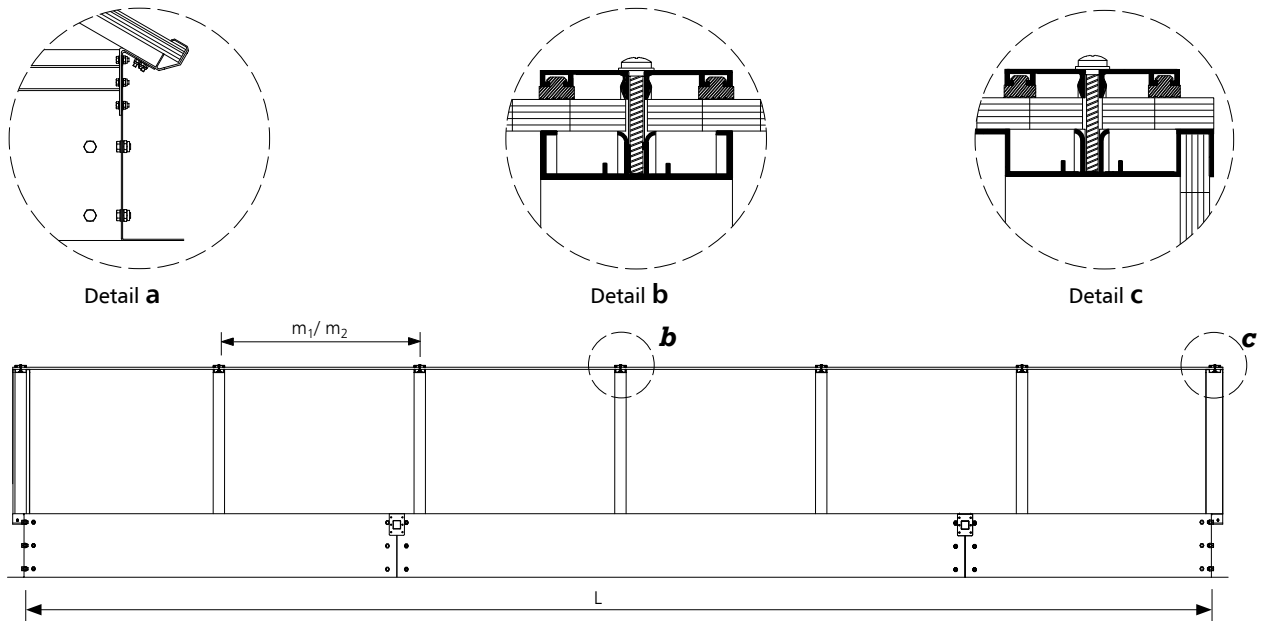

Fig.81 Cross section B-B of mcr PROLIGHT triangular shaped continuous rooflight

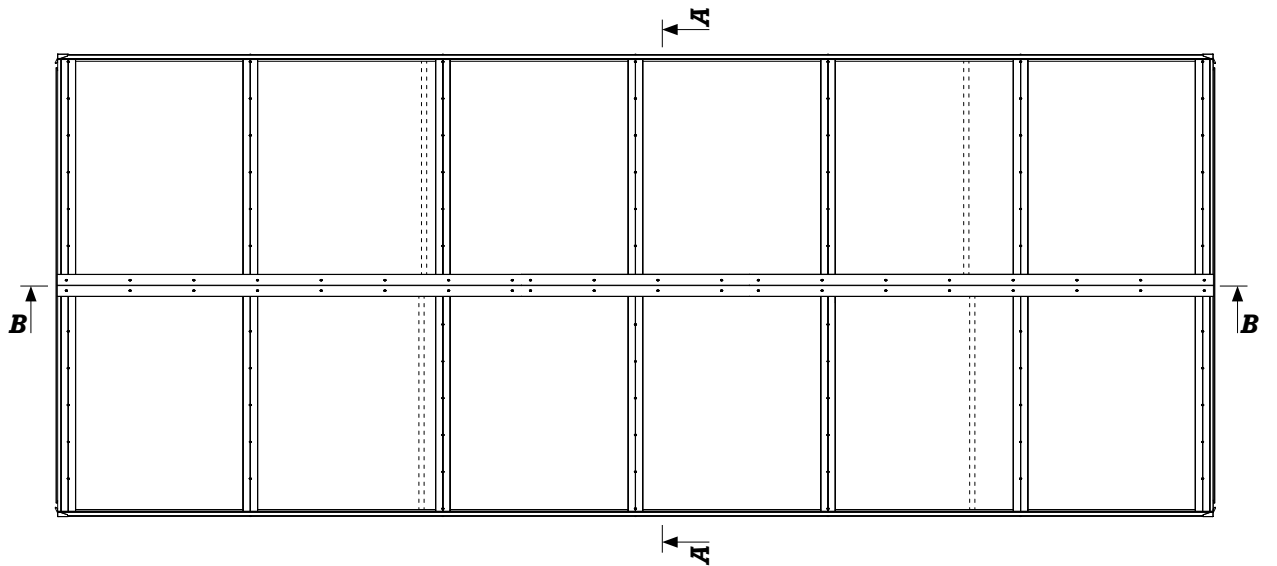

Fig.82 Top view of mcr PROLIGHT triangular shaped continuous rooflight

S – continuous rooflight span [m]
 H – continuous rooflight base height [mm]
 h – continuous rooflight height [mm], dependent on skylight angle of inclination and span

6.3.4 | Technical drawings of sample configurations of triangular shaped continuous rooflights with ventilation vents

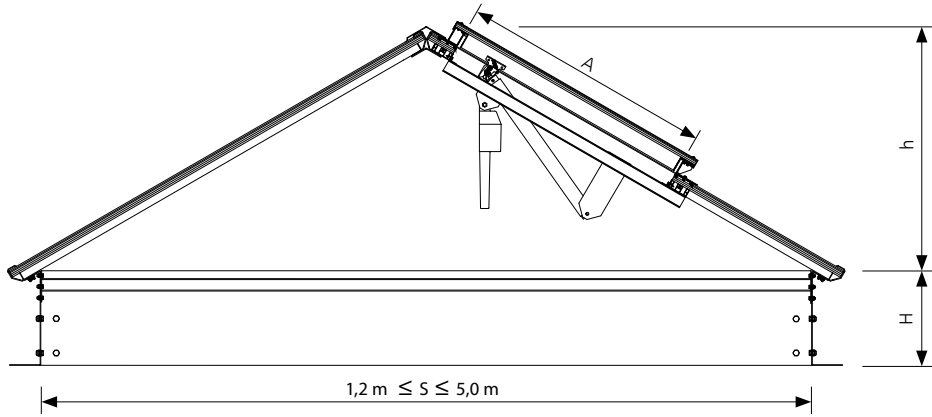

Fig.83 Cross section C-C of mcr PROLIGHT triangular shaped continuous rooflight with daily ventilation single-leaf vent

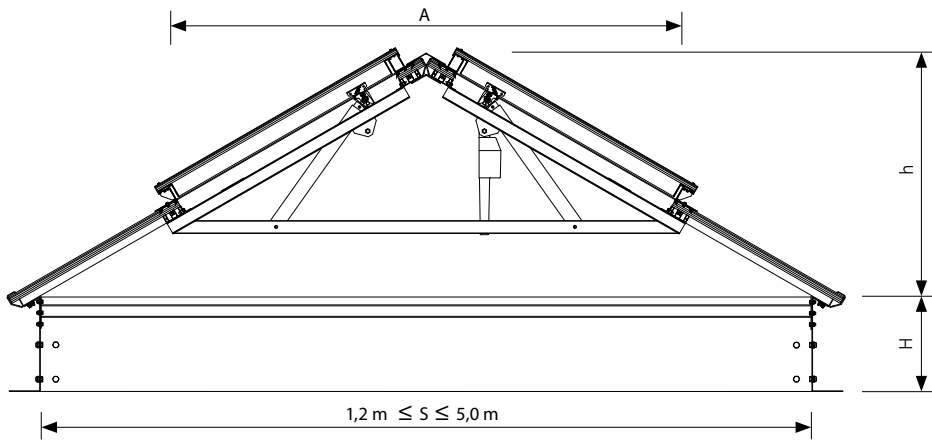

Fig.84 Cross section D-D of mcr PROLIGHT triangular shaped continuous rooflight with daily ventilation double-leaf vent

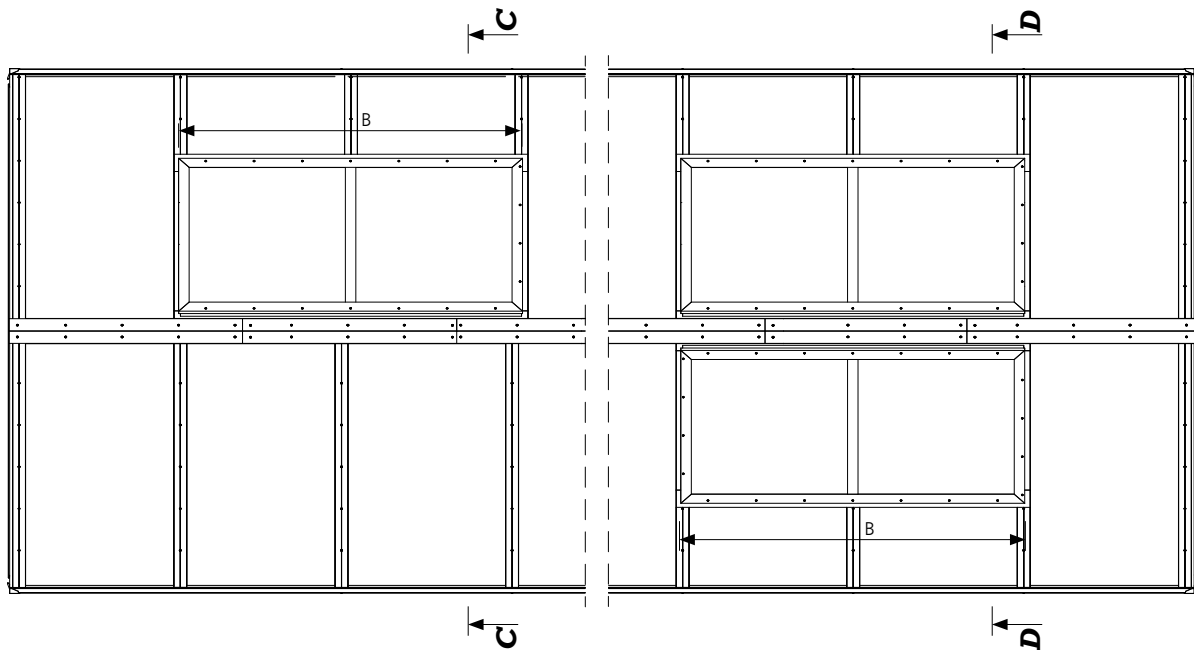

Fig.85 Top view of mcr PROLIGHT triangular shaped continuous rooflight with daily ventilation single-leaf and double-leaf vent

S – continuous rooflight span [m]
 H – continuous rooflight base height [mm]
 h – continuous rooflight height [mm], dependent on skylight angle of inclination and span
 A, B – nominal vent dimensions

6.3.5 | Available sizes for ventilation vents in triangular shaped continuous rooflights

NOMINAL DIMENSIONS [A x B] [mm]	NOTES (*)
630 x 650	Rooflights with module 710 mm
1000 x 650	Rooflights with module 710 mm
1200 x 650	Rooflights with module 710 mm
1000 x 1000	Rooflights with module 1060 mm
1200 x 1000	Rooflights with module 1060 mm
1400 x 1000	Rooflights with module 1060 mm
1000 x 2000	Rooflights with module 1060 mm
1200 x 2000	Rooflights with module 1060 mm
1400 x 2000	Rooflights with module 1060 mm
1000 x 1300	Rooflights with module 710 mm
1200 x 1300	Rooflights with module 710 mm
1260 x 1300	Rooflights with module 710 mm
1000 x 1900	Rooflights with module 710 mm
1200 x 1900	Rooflights with module 710 mm
1400 x 1900	Rooflights with module 710 mm
1500 x 1900	Rooflights with module 710 mm

(*) Module – Dimension between 2 bearing profiles of the rooflight which is either $m_1 = 710$ mm or $m_2 = 1060$ mm

6.4 | Pyramid skylights

6.4.1 | Technical description of standard

- » continuous rooflights in accordance with EN 14963,
- » width 1200 mm ÷ 5000 mm,
- » straight base of height 300 mm ÷ 700 mm made of galvanized steel sheet of thickness adequate to the skylight parameters (width, length, glazing thickness),
- » bottom part of base has a circumferential flange of standard width 70 mm, for installing on the roof structure,
- » skylight base adapted for installing thermal insulation of min. thickness 50 mm,
- » skylight structure made of aluminum profiles of shape ensuring water run-off,
- » continuous rooflights glazing made of multi-chamber polycarbonate, available in various thicknesses and colors,
- » continuous rooflights may be delivered with openable vents:
 - ventilation vents for daily ventilation of facilities,
- » ventilation control: electric 230 V~.

6.4.2 | Pyramid skylight design

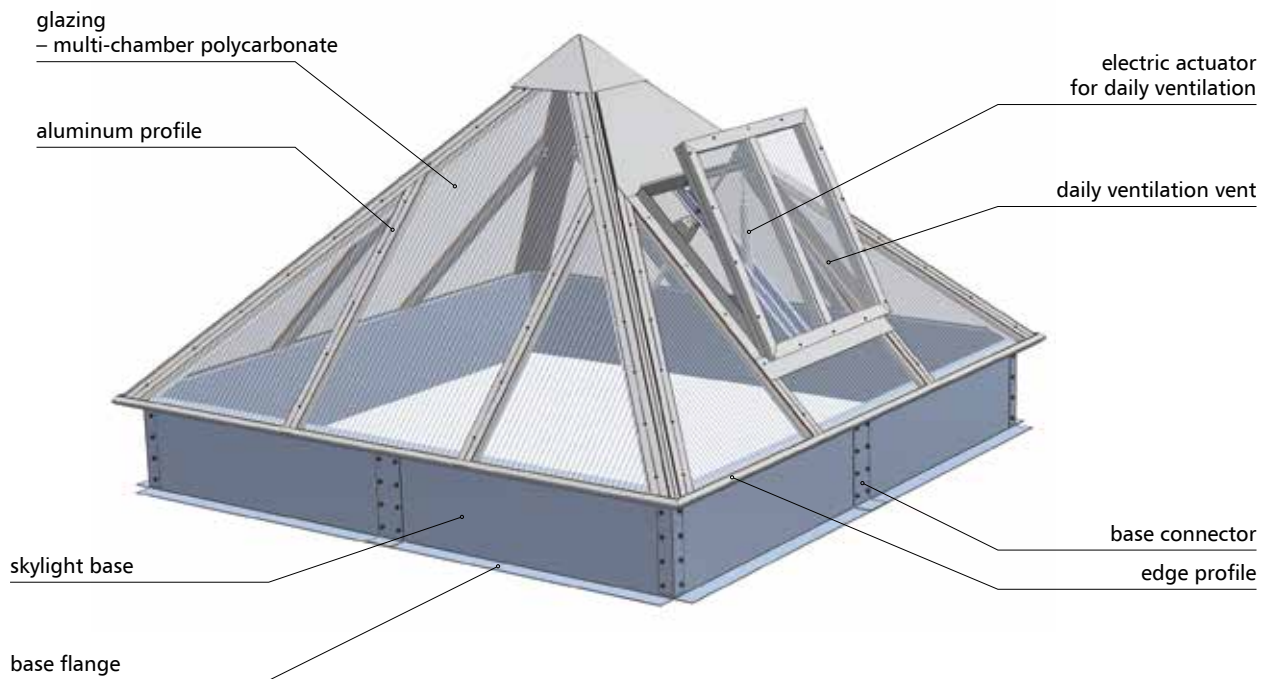

Fig.86 Design of mcr PROLIGHT pyramid skylight with smoke vent, with electric actuator for daily ventilation

6.4.3 | Technical drawings of pyramid skylight

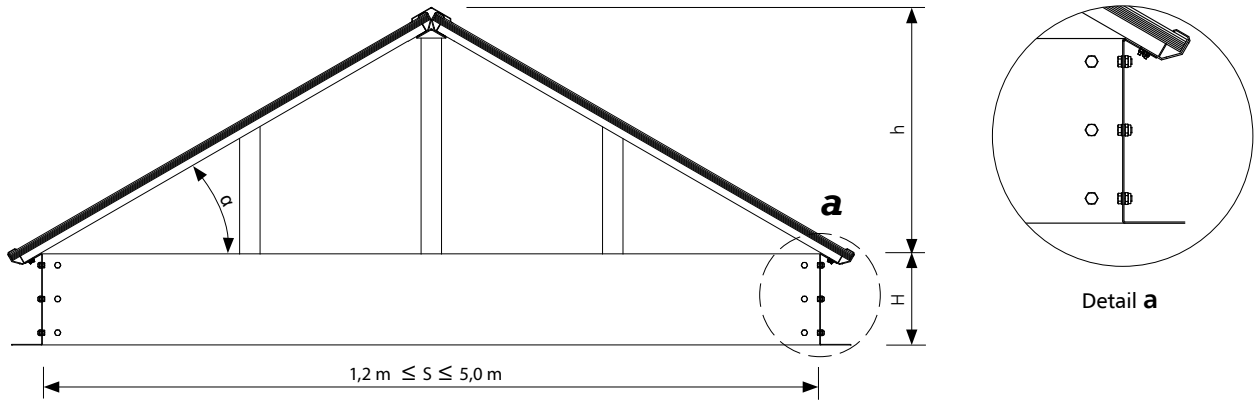

Fig.87 Cross section A-A of mcr PROLIGHT pyramid skylight

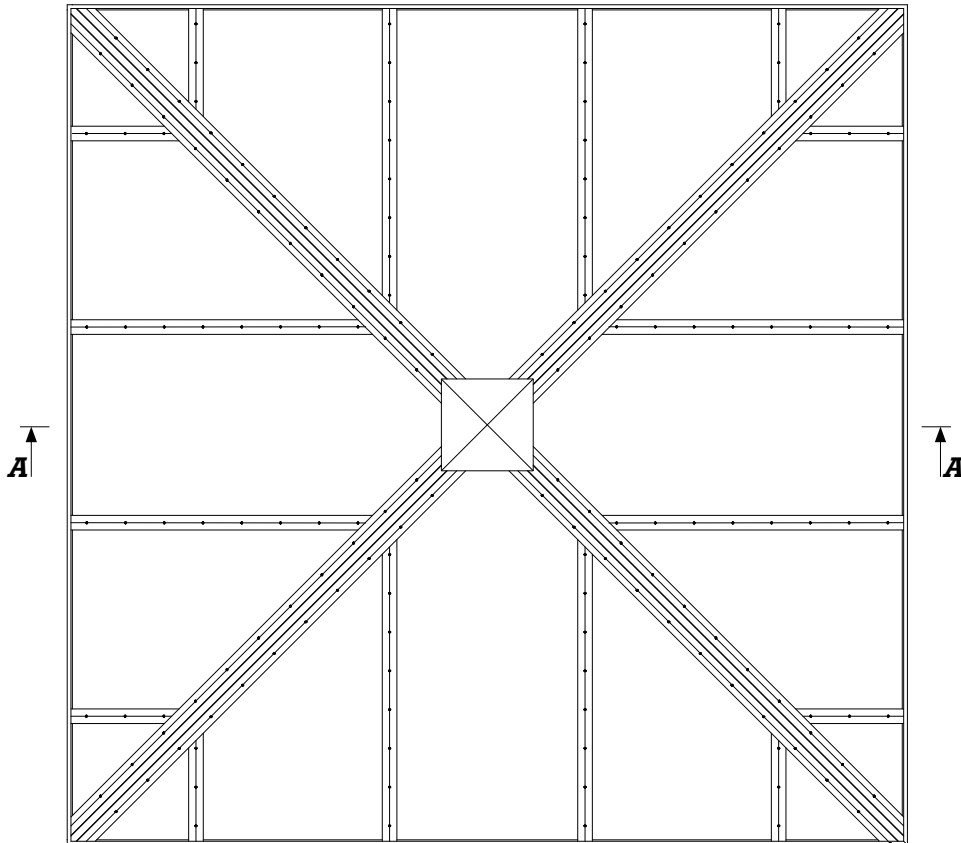

Fig.88 Top view of mcr PROLIGHT pyramid skylight

- S – skylight span [m]
- H – skylight base height [mm]
- h – skylight height [mm] – dependent on inclination angle
- α – inclination angle of rooflight walls, $30^\circ < \alpha < 60^\circ$

6.4.4 | Technical drawings of pyramid skylight with ventilation vent

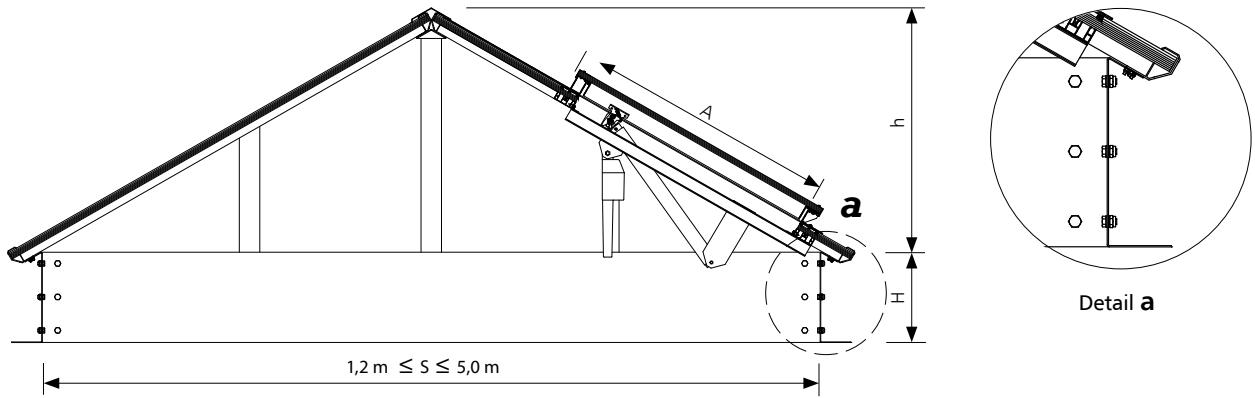

Fig.89 Cross section A-A of mcr PROLIGHT pyramid skylight with daily ventilation vent

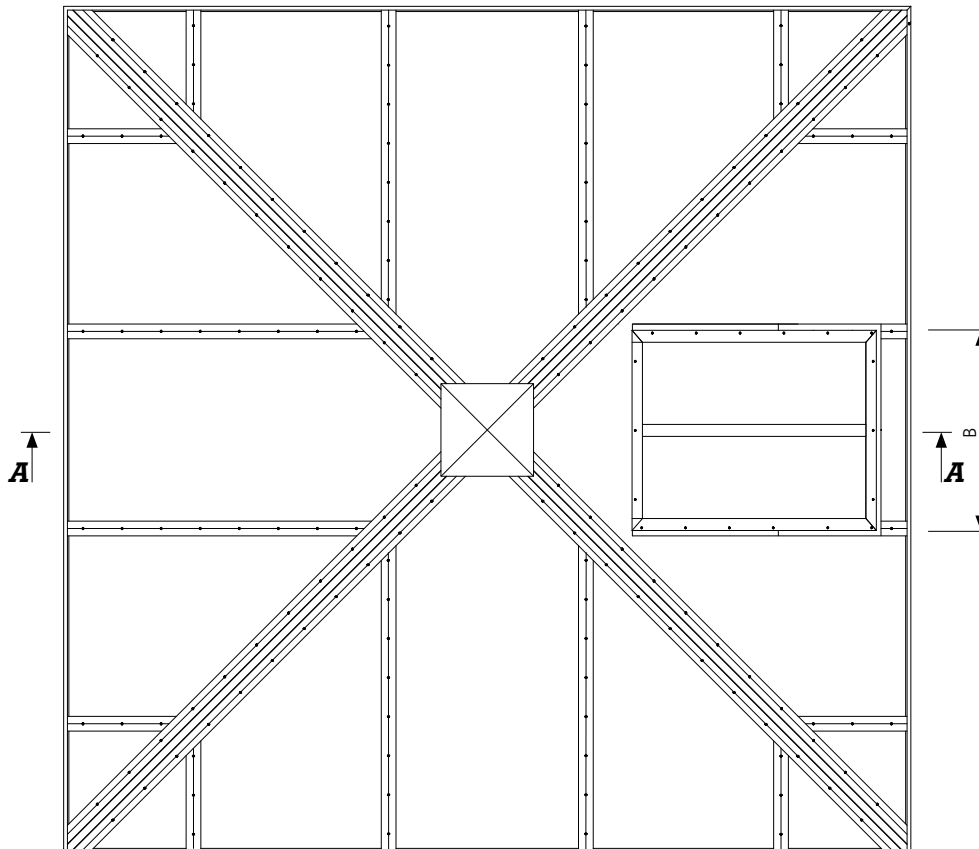

Fig.90 Top view of mcr PROLIGHT pyramid skylight with daily ventilation vent

- S – skylight span [m]
- H – skylight base height [mm]
- h – skylight height [mm] – dependent on inclination angle
- A, B – nominal vent dimensions

6.4.5 | Available sizes table for ventilation vents in pyramid skylights

NOMINAL DIMENSIONS [A x B] [mm]	NOTES(*)
650 x 650	Skylights with module 710 mm
1000 x 650	Skylights with module 710 mm
1200 x 650	Skylights with module 710 mm
1000 x 1000	Skylights with module 1060 mm
1200 x 1000	Skylights with module 1060 mm
1400 x 1000	Skylights with module 1060 mm
1000 x 1300	Skylights with module 710 mm
1200 x 1300	Skylights with module 710 mm
1260 x 1300	Skylights with module 710 mm

(*) Module – Dimension between 2 bearing profiles of the rooflight which is either $m_1 = 710\text{mm}$ or $m_2 = 1060\text{mm}$

6.5 | Igloo skylights

6.5.1 | Technical description of standard

- » continuous rooflights in accordance with EN14963,
- » width 1200 mm ÷ 6000 mm,
- » straight base of height 300 mm ÷ 700 mm made of galvanized steel sheet of thickness adequate to the skylight parameters (width, length, glazing thickness)
- » bottom part of base has a circumferential flange of standard width 70 mm, for installing on the roof structure,
- » skylight base adapted for installing thermal insulation of min. thickness 50 mm,
- » skylight structure made of aluminum profiles of shape ensuring water run-off,
- » multi-chamber polycarbonate skylight glazing available in various thicknesses and colors.

6.5.2 | Igloo skylight design

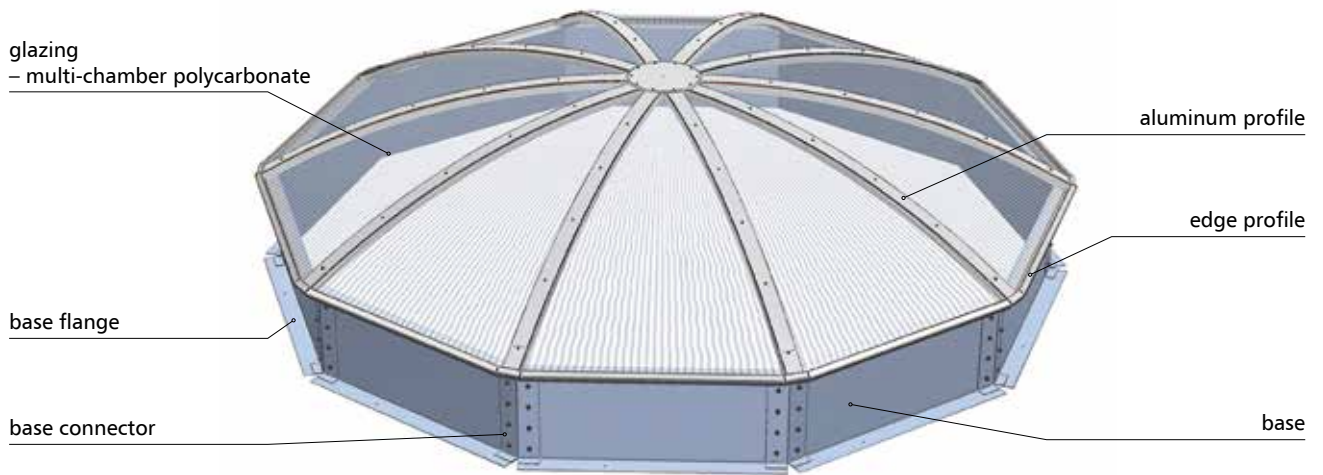

Fig.91 mcr PROLIGHT igloo skylight design

6.5.3 | Technical drawings of igloo skylight

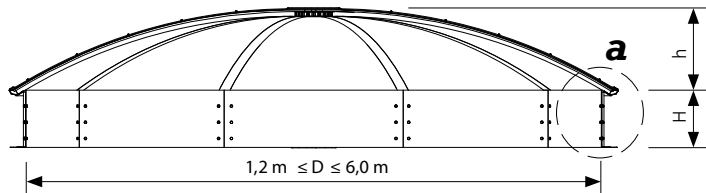
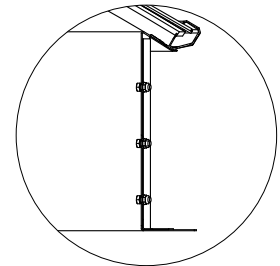

Fig.92 Cross section A-A of mcr PROLIGHT igloo skylight



Detail a

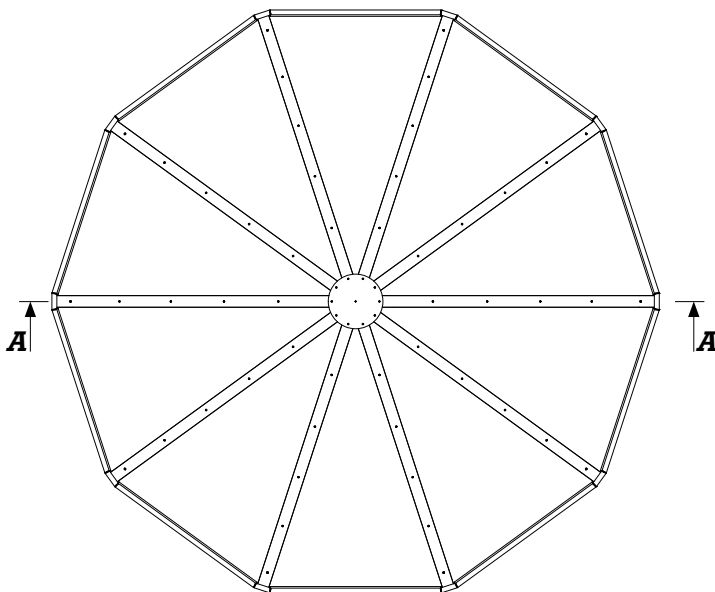
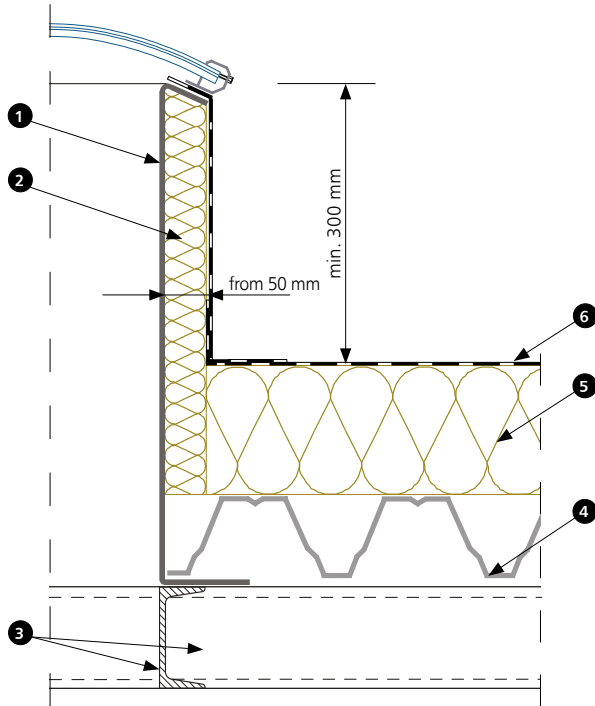

Fig.93 Top view of mcr PROLIGHT igloo skylight

D – skylight diameter [m]
 H – skylight base height [mm]
 h – skylight height [mm], dependent on igloo radius and skylight diameter [mm]

7 | Installation of continuous rooflight bases

7.1 | Installation of continuous rooflight bases on steel structure



- 1. continuous rooflight standard base
- 2. thermal insulation of base
- 3. supporting steel profile
- 4. trapezoidal metal sheet
- 5. thermal insulation of roof
- 6. PVC membrane

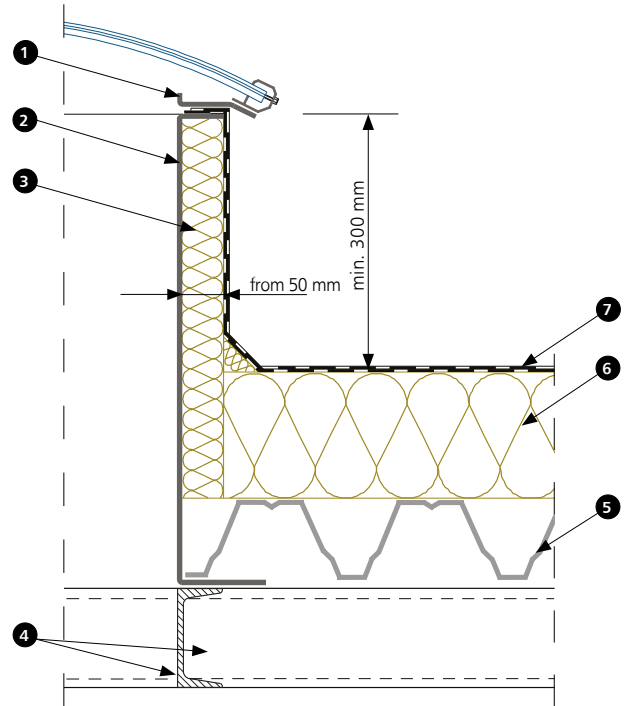

- 1. continuous rooflight standard base
- 2. thermal insulation of base
- 3. additional flashing
- 4. supporting steel profile
- 5. trapezoidal metal sheet
- 6. thermal insulation of roof
- 7. roofing paper

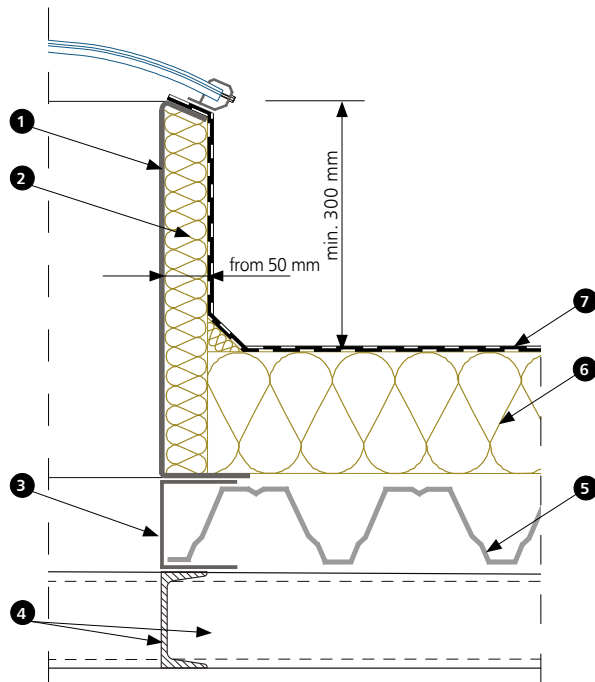

- 1. continuous rooflight overlay base
- 2. continuous rooflight standard base
- 3. thermal insulation of base
- 4. supporting steel profile
- 5. trapezoidal metal sheet
- 6. thermal insulation of roof
- 7. roofing paper

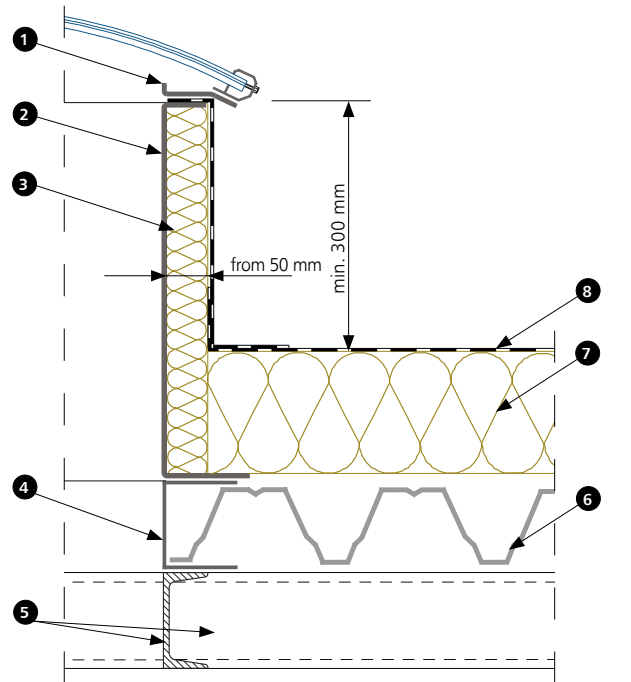

- 1. continuous rooflight overlay base
- 2. continuous rooflight standard base
- 3. thermal insulation of base
- 4. additional flashing
- 5. supporting steel profile
- 6. trapezoidal metal sheet
- 7. thermal insulation of roof
- 8. PVC membrane

7.2 | Installation of continuous rooflight bases on reinforced concrete structure

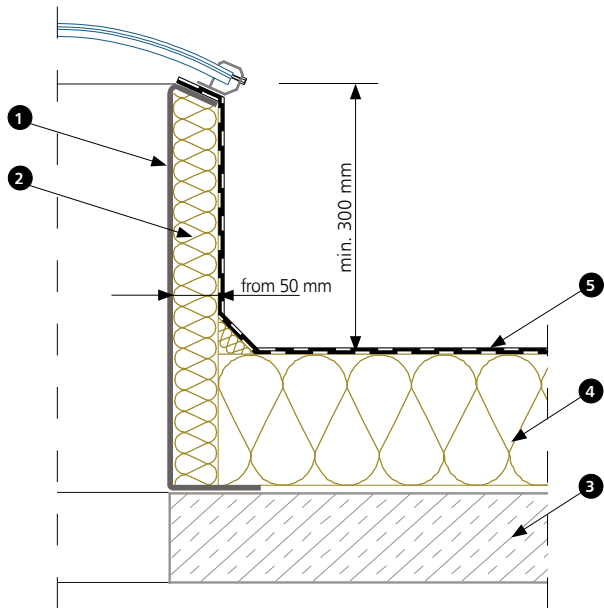

- 1. continuous rooflight standard base
- 2. thermal insulation of base
- 3. ceiling, e.g. reinforced concrete slab
- 4. thermal insulation of roof
- 5. roofing paper

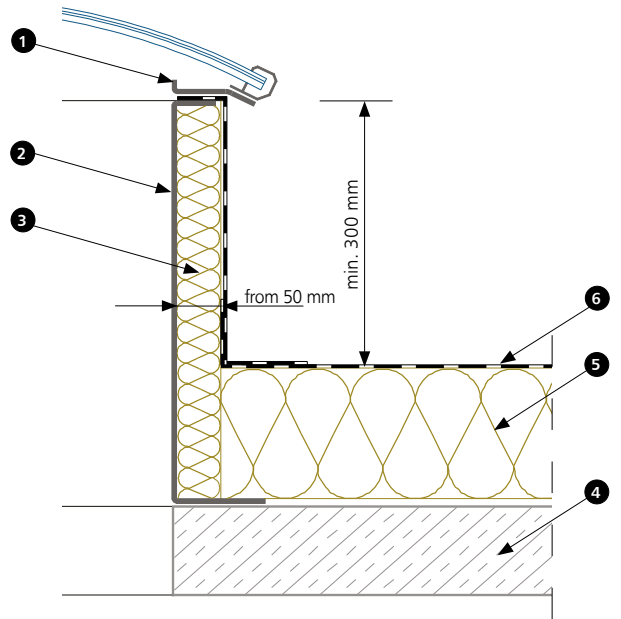

- 1. continuous rooflight overlay base
- 2. continuous rooflight standard base
- 3. thermal insulation of base
- 4. ceiling, e.g. reinforced concrete slab
- 5. thermal insulation of roof
- 6. PVC membrane

7.3 | Installation of continuous rooflight standard bases on reinforced concrete, steel or wooden plinth

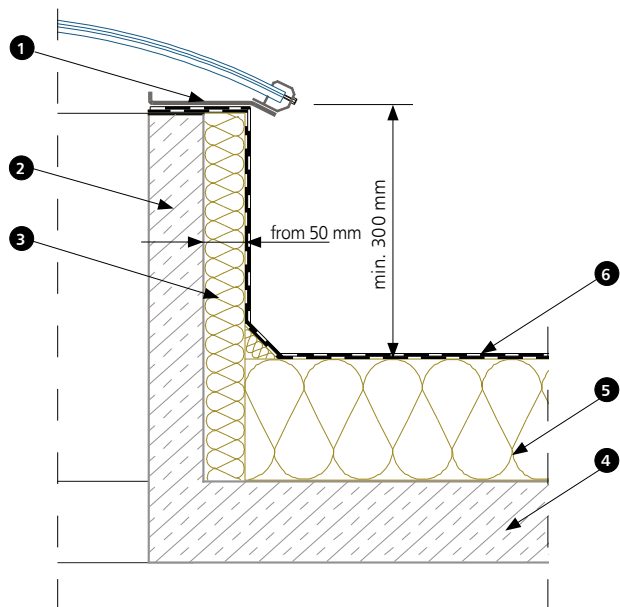

- 1. continuous rooflight overlay base
- 2. plinth (concrete, steel or wooden)
- 3. thermal insulation of plinth
- 4. ceiling, e.g. reinforced concrete slab
- 5. thermal insulation of roof
- 6. roofing paper

8 | **Continuous rooflight glazing**



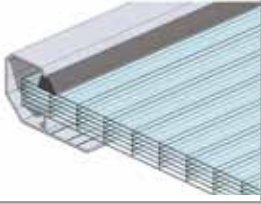
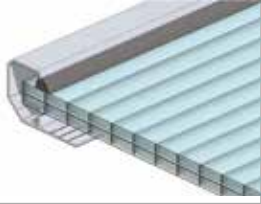
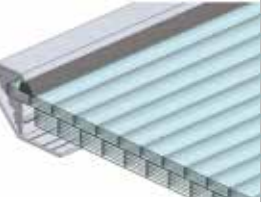
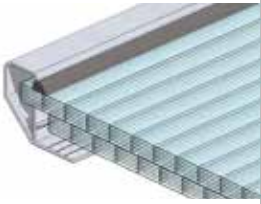
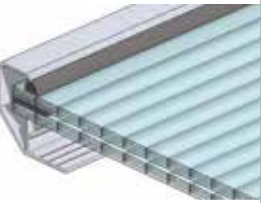
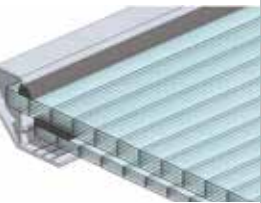
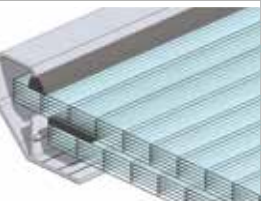

A wide range of glazing options is available for mcr PROLIGHT continuous rooflights. Choosing the right glazing will contribute:

- » sunlight intensity,
- » thermal insulation of building, and
- » operating safety.

Glazing type			Type			
			Arch shaped rooflight	Triangular shaped rooflight	Pyramidal shaped rooflight	Dome rooflight
Single	PCA		●	●	●	●
	PCA10 + PCA10		●	-	-	-
	PCA10 + PCA16		●	-	-	-
Multiple(*)	PCA16 + PCA16		●	-	-	-
	PCA10 + PP + PCA10		●	-	-	-
	PCA16 + PP + PCA10		●	-	-	-
Multiple with air gap (PP)(*)	PCA16 + PP + PCA16		●	-	-	-

(*) dimensional range for skylight specified to 4.0 m

LEGEND:
 PCA - multi-chamber polycarbonate panel (10-25 mm thickness)
 PCA10 / PCA16 / PCA20 multi-chamber polycarbonate panel of 10/16/20 mm thickness
 PP - air gap

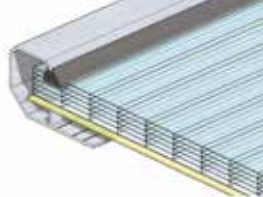
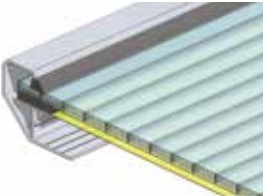
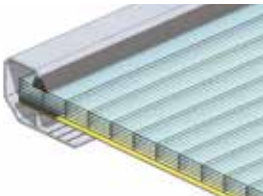
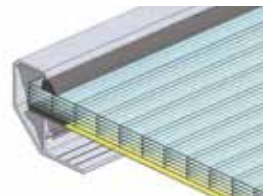
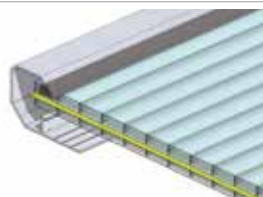
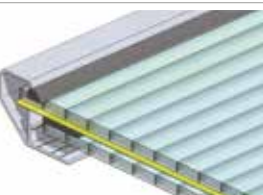
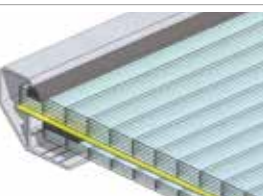
Glazing type		Type				
		Arch shaped rooflight	Triangular shaped rooflight	Pyramidal shaped rooflight	Dome rooflight	
						
Classification $B_{\text{roof}}(t_1)$ (*)	PCA + NRO		•	•	•	-
	PCA10 + PP + NRO		•	-	-	-
	PCA16 + PP + NRO		•	-	-	-
	PCA20 + PP + NRO		•	-	-	-
	PCA10+NRO+PCA10(**)		•	-	-	-
	PCA10+NRO+PP+PCA10		•	-	-	-
	PCA16+NRO+PP+PCA10		•	-	-	-

LEGEND:
 PCA- multi-chamber polycarbonate panel (10-25 mm thickness)
 PCA10 / PCA16 / PCA20 multi-chamber polycarbonate panel
 of 10/16/20 mm thickness

PP - air gap
 NRO - NRO polyester panel, $B_{\text{roof}}(t_1)$ glazing

(*) dimensional range for skylight specified to 4.0 m
 (**) dimensional range for skylight specified to 3.5 m

8.1 | Single glazing

8.1.1 | Multi-chamber polycarbonate panel (PCA)

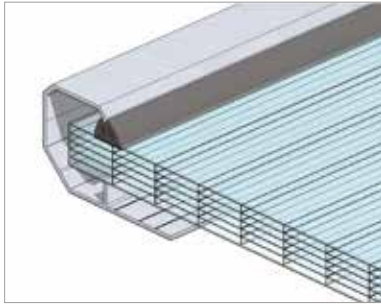

Fig.94 Skylight glazing – multi-chamber polycarbonate panel (PCA)

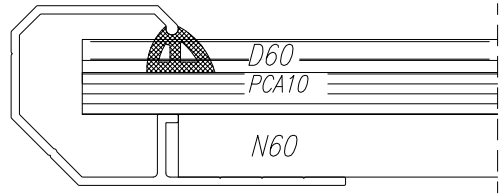

Fig.95 Skylight section; glazing: single multi-chamber polycarbonate panel

SINGLE PANEL PARAMETERS (PCA)	PCA 10 mm		PCA 16 mm	
	CLEAR	OPAL	CLEAR	OPAL
HEAT TRANSFER COEFFICIENT U	2,2 ÷ 2,9 W/m ² K		1,77 ÷ 2,0 W/m ² K	
LIGHT TRANSMISSION L _t	64 ÷ 65 %	44 ÷ 66 %	54 ÷ 64 %	45 ÷ 47 %
ACOUSTIC INSULATION R _w	18 ÷ 19 dB		18 ÷ 19 dB	
FIRE PERFORMANCE (AS PER EN 13501-1)	B-s1,d0		B-s1,d0/ B-s2,d0	

SINGLE PANEL PARAMETERS (PCA)	PCA 20 mm		PCA 25 mm	
	CLEAR	OPAL	CLEAR	OPAL
HEAT TRANSFER COEFFICIENT U	1,59 ÷ 1,8 W/m ² K		1,4 ÷ 1,6 W/m ² K	
LIGHT TRANSMISSION L _t	45 ÷ 47 %	51 %	44 %	45 ÷ 47 %
ACOUSTIC INSULATION R _w	21 dB		22 dB	
FIRE PERFORMANCE (AS PER EN 13501-1)	B-s1,d0/B-s2,d0		B-s2,d0	

8.2 | Multi-layer glazing

8.2.1 | Two multi-chamber polycarbonate 10 mm panels (PCA10 + PCA10)

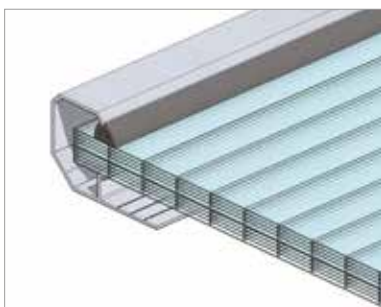

Fig.96 Skylight glazing – two multi-chamber polycarbonate panels (PCA10 + PCA10)

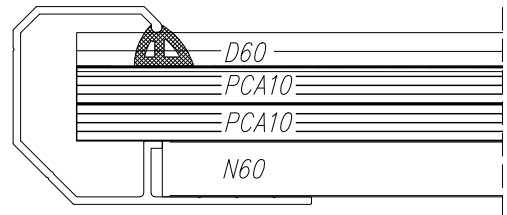

Fig.97 Section of skylight of width 1.2 ÷ 3.5 m; supporting profile (N) and pressing profile (D) of width 60 mm

PANEL SET PARAMETERS (PCA10 + PCA10)	PCA 10mm + PCA 10 mm	
	CLEAR	OPAL
HEAT TRANSFER COEFFICIENT U	1,3 ÷ 1,8 W/m ² K	
LIGHT TRANSMISSION L _t	53 ÷ 77%	19 ÷ 58%
ACOUSTIC INSULATION R _w	min. 19 dB	
FIRE PERFORMANCE (AS PER EN 13501-1)	B-s1,d0	

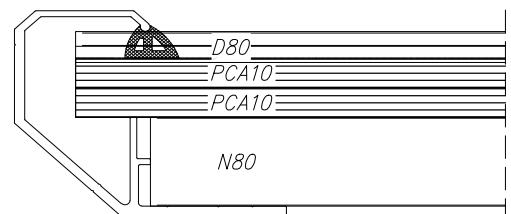

Fig.98 Section of skylight of width 3.5 ÷ 4.0 m; supporting profile (N) and pressing profile (D) of width 80 mm

8.2.2 | Two multi-chamber polycarbonate 10 mm and 16 mm panels (PCA10 + PCA16)

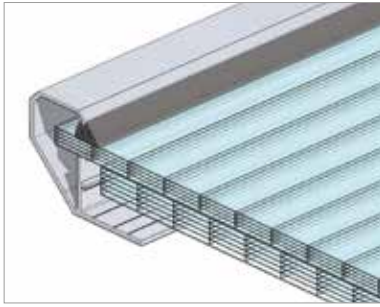

Fig.99 Skylight glazing – two multi-chamber polycarbonate panels (PCA10 + PCA16)

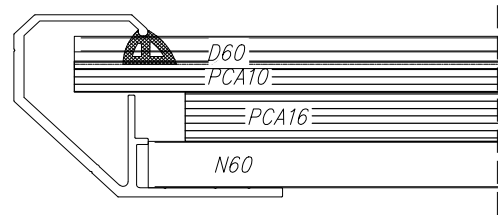

Fig.100 Section of skylight of width 1.5÷4.0 m; supporting profile (N) and pressing profile (D) of width 60 mm

PANEL SET PARAMETERS (PCA10 + PCA16)	PCA 10mm + PCA 16 mm	
	CLEAR	OPAL
HEAT TRANSFER COEFFICIENT U	1,1 ÷ 1,4 W/m ² K	
LIGHT TRANSMISION L _t	39 ÷ 64%	13 ÷ 54%
ACOUSTIC INSULATION R _w	min. 18 dB	
FIRE PERFORMANCE (AS PER EN 13501-1)	B-s1,d0/B-s2,d0	

8.2.3 | Two multi-chamber polycarbonate 16mm panels (PCA16+PCA16)

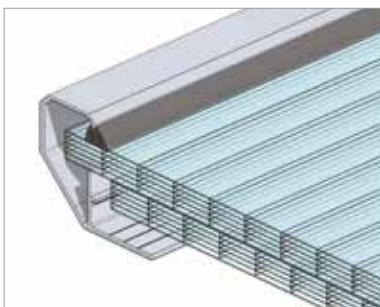

Fig.101 Skylight glazing – two multi-chamber polycarbonate panels (PCA16 + PCA16)

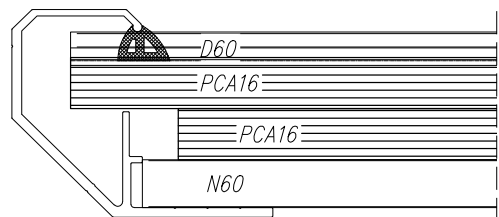

Fig.102 Section of skylight of width 1.5÷6.0 m; supporting profile (N) and pressing profile (D) of width 60 mm

PANEL SET PARAMETERS (PCA16 + PCA16)	PCA 16mm + PCA 16 mm	
	CLEAR	OPAL
HEAT TRANSFER COEFFICIENT U	1,0 ÷ 1,1 W/m ² K	
LIGHT TRANSMISION L _t	29% ÷ 47%	9% ÷ 29%
ACOUSTIC INSULATION R _w	min. 18 dB	
FIRE PERFORMANCE (AS PER EN 13501-1)	B-s1,d0/B-s2,d0	

8.2.4 | Two multi-chamber polycarbonate 10 mm panels with air gap (PCA10 + PP + PCA10)



Fig.103 Skylight glazing – two multi-chamber polycarbonate panels (PCA10 + PCA10) with air gap between (PP)

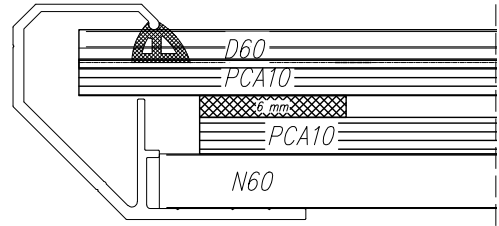

Fig.104 Section of skylight of width 1.2÷3.5 m; supporting profile (N) and pressing profile (D) of width 60 mm

PANEL SET PARAMETERS (PCA10 + PP + PCA10)	PCA 10mm + PP + PCA 10 mm	
	CLEAR	OPAL
HEAT TRANSFER COEFFICIENT U	1,3÷1,8 W/m ² K	
LIGHT TRANSMISSION L _t	53÷77%	19÷58%
ACOUSTIC INSULATION R _w	min. 19 dB	
FIRE PERFORMANCE (AS PER EN 13501-1)	B-s1,d0	

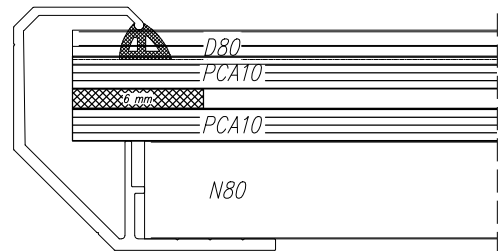

Fig.105 Section of skylight of width 3.5÷4.0 m; supporting profile (N) and pressing profile (D) of width 80 mm

8.2.5 | Two multi-chamber polycarbonate 16 mm and 10 mm panels with air gap (PCA16 + PP + PCA10)

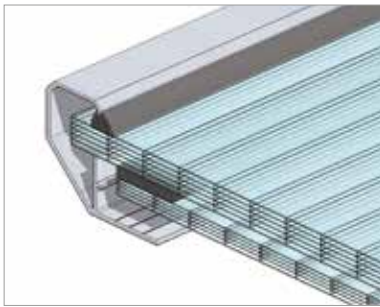

Fig.106 Skylight glazing – two multi-chamber polycarbonate panels (PCA16 + PCA10) with air gap between (PP)

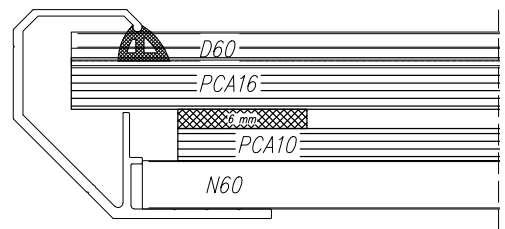

Fig.107 Section of skylight of width 1.5÷6.0 m; supporting profile (N) and pressing profile (D) of width 60 mm

PANEL SET PARAMETERS (PCA16 + PP + PCA10)	PCA 16mm + PP + PCA 10 mm	
	CLEAR	OPAL
HEAT TRANSFER COEFFICIENT U	1,0÷1,1 W/m ² K	
LIGHT TRANSMISSION L _t	39÷64%	13÷54%
ACOUSTIC INSULATION R _w	min. 18 dB	
FIRE PERFORMANCE (AS PER EN 13501-1)	B-s1,d0/B-s2,d0	

8.2.6 | Two multi-chamber polycarbonate 16 mm panels with air gap (PCA16 + PP + PCA16)

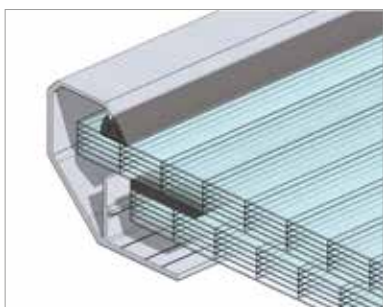

Fig.108 Skylight glazing – two multi-chamber polycarbonate panels (PCA16 + PCA16) with air gap between (PP)

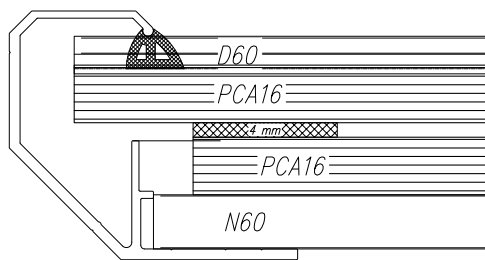

Fig.109 Section of skylight of width 1.5÷4.0 m; supporting profile (N) and pressing profile (D) of width 60 mm

PANEL SET PARAMETERS (PCA16 + PP + PCA16)	PCA 16mm + PP + PCA 16 mm	
	CLEAR	OPAL
HEAT TRANSFER COEFFICIENT U	0,9÷1,0 W/m ² K	
LIGHT TRANSMISION L _t	20÷22%	13÷54%
ACOUSTIC INSULATION R _w	min. 21 dB	
FIRE PERFORMANCE (AS PER EN 13501-1)	B-s1,d0	

8.2.7 | Multi-chamber polycarbonate panel and NRO panel (PCA + NRO)

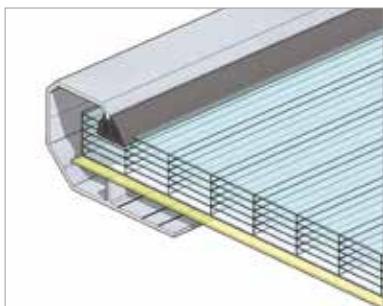

Fig.110 Skylight glazing – multi-chamber polycarbonate panel (PCA), NRO panel

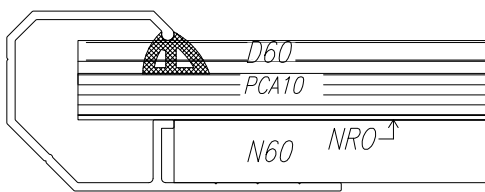

Fig.111 Skylight section; glazing - single multi-chamber polycarbonate panel and NRO panel

PANEL SET PARAMETERS (PCA) POLYESTER PANEL NRO	PCA 10 mm + NRO		PCA 16 mm + NRO	
	CLEAR	OPAL	CLEAR	OPAL
HEAT TRANSFER COEFFICIENT U	2,2÷2,9 W/m ² K		1,77÷2,0 W/m ² K	
LIGHT TRANSMISION L _t	64÷65 %	44÷66 %	54÷64 %	45÷47 %
ACOUSTIC INSULATION R _w	18÷19 dB		18÷19 dB	
FIRE PERFORMANCE (AS PER EN 13501-1)	B _{ROOF} (t1)		B _{ROOF} (t1)	

PANEL SET PARAMETERS (PCA)	PCA 20 mm + NRO		PCA 25 mm + NRO	
	CLEAR	OPAL	CLEAR	OPAL
HEAT TRANSFER COEFFICIENT U	1,59÷1,8 W/m ² K		1,4÷1,6 W/m ² K	
LIGHT TRANSMISION L _t	53÷62 %	45÷47 %	51 %	44 %
ACOUSTIC INSULATION R _w	21 dB		22 dB	
FIRE PERFORMANCE (AS PER EN 13501-1)	B _{ROOF} (t1)		B _{ROOF} (t1)	

8.2.8 | 10 mm multi-chamber polycarbonate panel, air gap and NRO panel (PCA10 + PP + NRO)

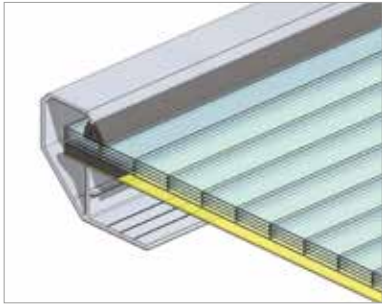

Fig.112 Skylight glazing: multi-chamber polycarbonate panel (PCA10), NRO panel with air gap between (PP)

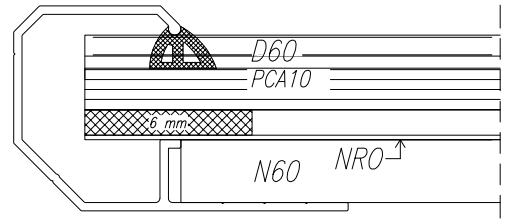

Fig.113 Section of skylight of width 1.5÷4.0 m; supporting profile (N) and pressing profile (D) of width 60 mm

PANEL SET PARAMETERS (PCA10 + PP + NRO)	PCA 10 mm + PP + NRO	
	CLEAR	OPAL
HEAT TRANSFER COEFFICIENT U	1,8÷2,0 W/m ² K	
LIGHT TRANSMISION L _t	13÷24%	06÷18%
ACOUSTIC INSULATION R _w	min. 19 dB	
FIRE PERFORMANCE (AS PER EN 13501-1)	B _{Roof} (t1)	

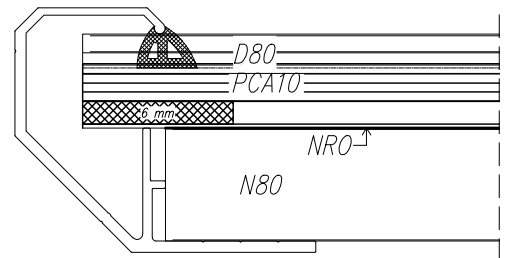

Fig.114 Section of skylight of width 1.5÷4.0 m; supporting profile (N) and pressing profile (D) of width 80 mm

8.2.9 | 16 mm multi-chamber polycarbonate panel, air gap and NRO panel (PCA16 + PP + NRO)

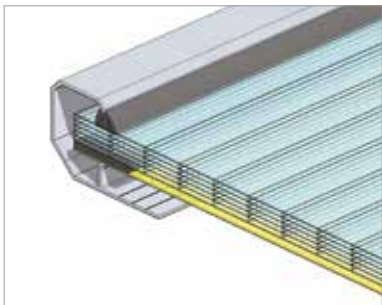

Fig.115 Skylight glazing: multi-chamber polycarbonate panel (PCA16), NRO panel with air gap between (PP)

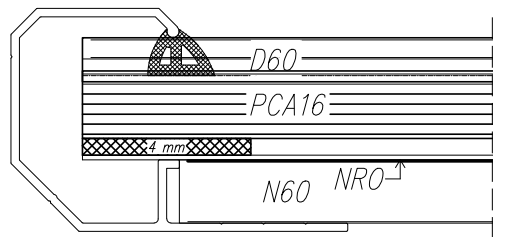

Fig.116 Section of skylight of width 1.5÷4.0 m; supporting profile (N) and pressing profile (D) of width 60 mm

PANEL SET PARAMETERS (PCA16 + PP + NRO)	PCA 16 mm + PP + NRO	
	CLEAR	OPAL
HEAT TRANSFER COEFFICIENT U	1,5÷1,6 W/m ² K	
LIGHT TRANSMISION L _t	11÷21%	06÷16%
ACOUSTIC INSULATION R _w	min. 19 dB	
FIRE PERFORMANCE (AS PER EN 13501-1)	B _{Roof} (t1)	

8.2.10 | 20 mm multi-chamber polycarbonate panel, air gap and NRO panel (PCA20 + PP + NRO)

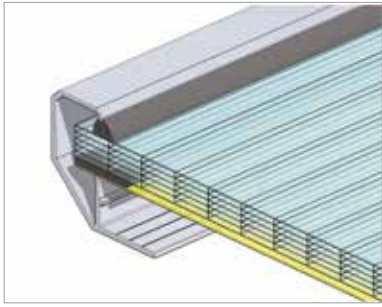

Fig.117 Skylight glazing: multi-chamber polycarbonate panel (PCA20), NRO panel with air gap between (PP)

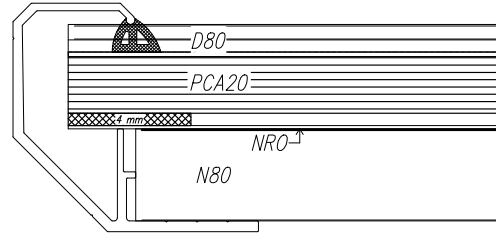

Fig.118 Section of skylight of width 1.5÷4.0 m; supporting profile (N) and pressing profile (D) of width 60 mm

PANEL SET PARAMETERS (PCA20 + PP + NRO)	PCA 20 mm + PP + NRO	
	CLEAR	OPAL
HEAT TRANSFER COEFFICIENT U	1,3÷1,4 W/m ² K	
LIGHT TRANSMISSION L _t	11÷19%	5÷16%
ACOUSTIC INSULATION R _w	min. 19 dB	
FIRE PERFORMANCE (AS PER EN 13501-1)	B _{ROOF} (t1)	

8.2.11 | Multi-chamber polycarbonate 10 mm panel and NRO panel (PCA10 + NRO + PCA10)

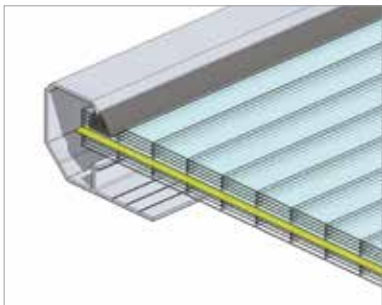

Fig.119 Skylight glazing: two multi-chamber polycarbonate panels (PCA10+PCA10) with NRO panel between

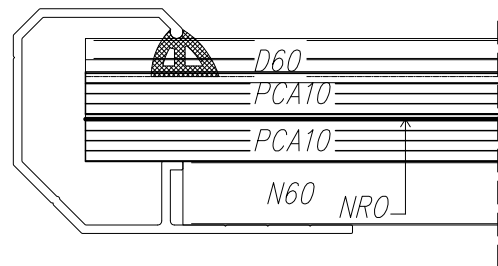

Fig.120 Section of skylight of width 1.2÷3.5 m; supporting profile (N) and pressing profile (D) of width 60 mm

PANEL SET PARAMETERS (PCA10 + NRO + PCA10)	PCA 10 mm + NRO + PCA10	
	CLEAR	OPAL
HEAT TRANSFER COEFFICIENT U	1,3÷1,5 W/m ² K	
LIGHT TRANSMISSION L _t	10÷22%	4÷17%
ACOUSTIC INSULATION R _w	min. 19 dB	
FIRE PERFORMANCE (AS PER EN 13501-1)	B _{ROOF} (t1)	

8.2.12 | Multi-chamber polycarbonate 10 mm panel with NRO panel and air gap (PCA10 + NRO + PP + PCA10)

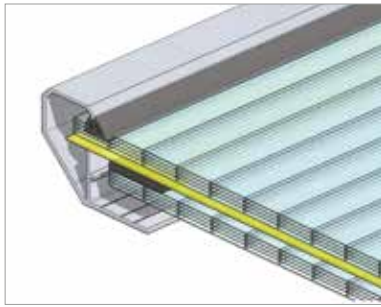

Fig.121 Skylight glazing: two multi-chamber polycarbonate panels (PCA10+PCA10) with air gap (PP) and NRO panel between

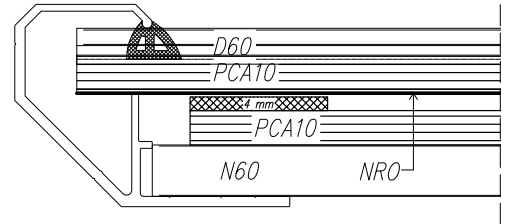

Fig.122 Section of skylight of width 1.5÷4.0 m; supporting profile (N) and pressing profile (D) of width 60 mm

PANEL SET PARAMETERS (PCA10 + NRO + PP + PCA10)	PCA 10 mm + NRO + PP + PCA10	
	CLEAR	OPAL
HEAT TRANSFER COEFFICIENT U	1,2÷1,3 W/m ² K	
LIGHT TRANSMISSION L _t	10÷22%	4÷17%
ACOUSTIC INSULATION R _w	min. 18 dB	
FIRE PERFORMANCE (AS PER EN 13501-1)	B _{ROOF} (t1)	

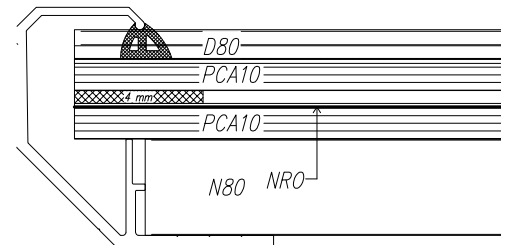

Fig.123 Skylight glazing – multi-chamber polycarbonate panel (PCA), NRO panel

8.2.13 | Two multi-chamber polycarbonate 16 mm and 10 mm panels with NRO panel and air gap (PCA16 + NRO + PP + PCA10)

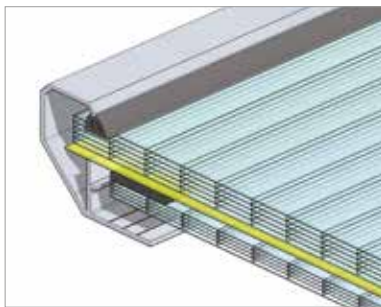

Fig.124 Skylight glazing: two multi-chamber polycarbonate panels (PCA16+PCA10) with NRO panel and air gap (PP) between

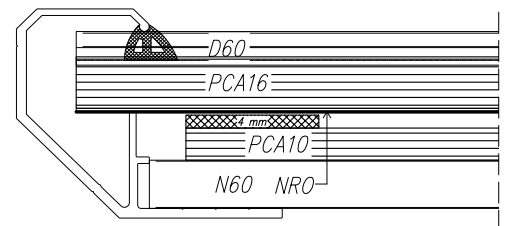
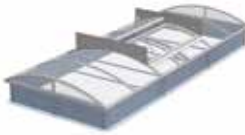





Fig.125 Section of skylight of width 1.5÷4.0 m; supporting profile (N) and pressing profile (D) of width 60 mm

PANEL SET PARAMETERS (PCA16 + NRO + PP + PCA10)	PCA 16 mm + NRO + PP + PCA10	
	CLEAR	OPAL
HEAT TRANSFER COEFFICIENT U	1,0÷1,1 W/m ² K	
LIGHT TRANSMISSION L _t	2÷16%	06÷16%
ACOUSTIC INSULATION R _w	min. 18 dB	
FIRE PERFORMANCE (AS PER EN 13501-1)	B _{ROOF} (t1)	

9 | Additional equipment for continuous rooflights

Equipment	Wind deflectors	Anti-burglar grid	Safety net	Limit switch
Product type				
Smoke vents in continuous rooflights	•	•	•	•
Daily ventilation vents in continuous rooflights	•	•	•	•
Fixed continuous rooflights (without vents)	-	• (*)	• (**)	-

(*) Anti-burglar grid available only for selected dimensions of continuous rooflights

(**) Safety net available only for selected dimensions of continuous rooflights

9.1 | Wind deflectors

- » a smoke vent element increasing its active area,
- » wind deflectors are used in:
 - vents installed in arch-shaped rooflight as optional accessory,
- » they consists of wind shield fixed to the base with mounting consoles,
- » wind deflectors dimensions range: 100 ÷ 300 mm (depending on type and width of vent integrated in rooflight),
- » wind shields made of aluminum sheet; mounting consoles made of galvanized steel sheet,
- » wind shields delivered as separate elements to be assembled on site (with previously installed mounting consoles),
- » non-standard options:
 - powder coating of wind deflectors

Wind deflectors are installed in smoke vents in pairs:

- » at corners of the vent base, opposite to the hinges side (single leaf)
- » along side walls of the base (double leaf)

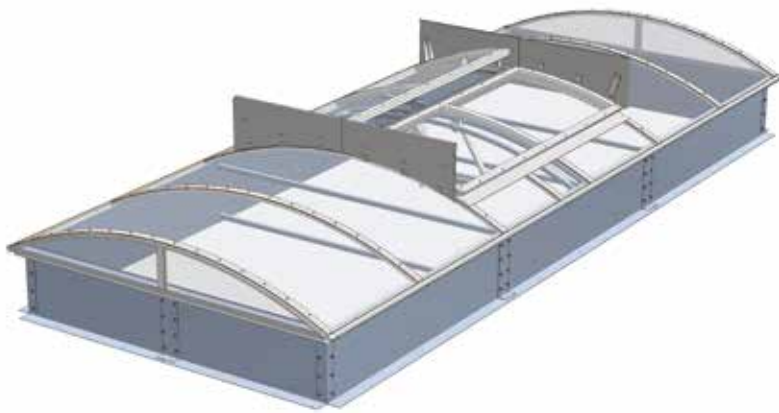

Fig.126 Wind deflectors in smoke vent installed in continuous rooflight

9.2 | Anti-burglar grid

- » application in vents within the full dimensional range in continuous rooflights of span up to 6 m,
- » prevents from access of unauthorized persons, and from falling inside,
- » conforms to class 2 anti-burglar resistance as per ENV 1627,
- » resistant to impact of large, soft body, up to maximum energy of 1200 J - corresponds to SB1200 class as per EN 1873 standard,
- » made of 21 mm galvanized steel rods fixed in steel sections; the pipes rotate, preventing sawing off,
- » rods additionally stringed with cross-bar,
- » grid installed in the device base,
- » maximum distance between rods of the grid - 180 mm,
- » powder painted or galvanized grid.



Fig.127 Anti-burglar grid installed in continuous rooflight base

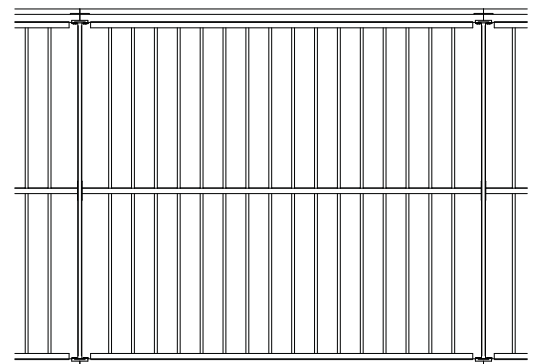

Fig.128 Top view of anti-burglar of installed in continuous rooflight

9.3 | Safety net

- » application in vents within the full dimensional range in continuous rooflights of span up to 3.6 m,
- » protects from falling through the vent,
- » resistant to impact of large, soft body, up to maximum energy of 1200 J - corresponds to SB1200 class as per EN 1873 standard,
- » net installed in the device base,
- » made of galvanized steel rods of 4÷8 mm diameter, with 100x100 mm to 150x650 mm mesh,
- » net non-standard options:
 - powder coating
 - openable net for mcr PROLIGHT smoke vents with roof access function
- » optional safety (safeguard) net making, conformant with EN 1263-1, providing fall protection; the net is made of polypropylene ropes and installed in the vent base.

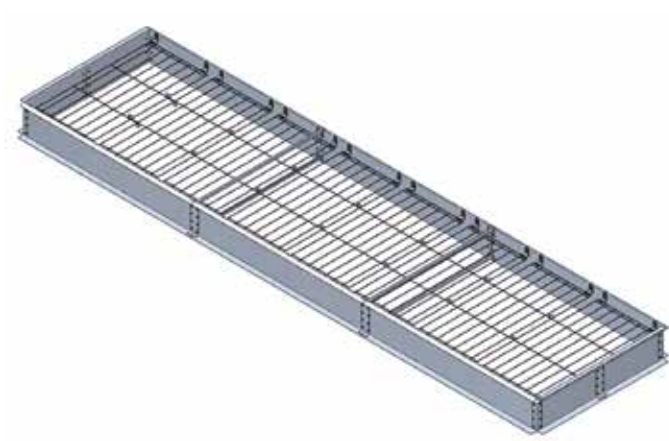

Fig.129 Safety net installed in continuous rooflight

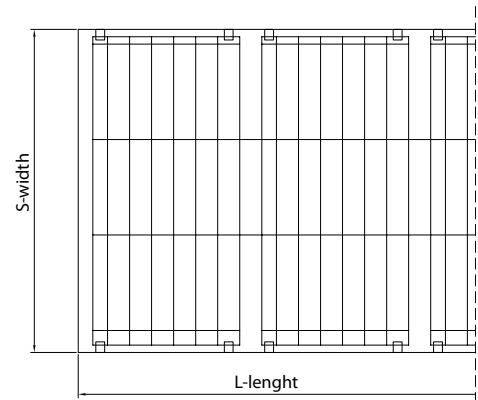

Fig.130 Top view of safety net installed in continuous rooflight

9.4 | Limit switch

- » indicates the position of smoke vent or ventilation vent leaf, displaying the position status on a control panel, or gives signal to fire signalling system
- » three position status indications are possible:
 - full closed position,
 - full open position,
 - any open position,
- » includes 1xNO and 1xNC voltage-free contacts,
- » nominal voltage range up to 250 V~ or up to 400 V-,
- » maximum current-carrying capacity of contacts 10A (resistance load), dependent on load characteristics,
- » switching frequency 3 600 cycles/hour,
- » operating temperature range -25°C ÷ 70°C.
- » switch casing protection rating IP65

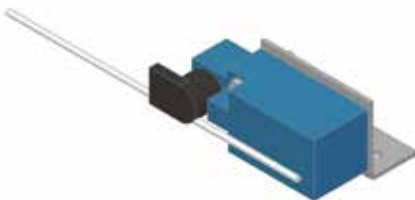

Fig.131 Limit switch in smoke vent installed in continuous rooflight



„MERCOR” S.A.
ul. Grzegorza z Sanoka 2 80-408 Gdańsk
tel. + 48 58 341 42 45
export@mercorgroup.com.pl

> MERCOR UKRAINE SP. Z O.O.

Ukraine

www.mercor.com.ua

📍 Scheptyckich 26

📍 79-016 Lviv

☎ +380 32 240 34 47

☎ +380 32 240 34 07

✉ info@mercorgroup.com.ua

> MERCOR FIRE PROTECTION SYSTEMS S.C. S.R.L.

Romania

www.mercor.ro

📍 Drum Centura Chitila - Mogosoaia, no 3, floor 4

📍 Oras Chitila, Ilfov RO-077045

☎ +40 371 324 182

☎ +40 372 877 070

✉ romania@mercorgroup.com.pl

> MERCOR TECRESA

Spain

Parque Tecnológico Legatec.

www.mercortecresa.com

📍 C/ Margarita Salas nº 6

📍 28919 Leganés (Madrid)

☎ +34 91 428 22 60

☎ +34 91 428 22 62

✉ info@mercortecresa.com

> MERCOR SLOVAKIA S.R.O.

Slovakia

www.mercor-slovakia.sk

📍 Galvaniho 7/D

📍 821 04 Bratislava

☎ +421 2 2062 0040

☎ +421 2 2062 0049

✉ mercor@mercorgroup-slovakia.sk

> MERCOR CZECH REPUBLIC S.R.O.

Czech Republic

www.mercor-czech.cz

📍 Letní 1122/1

📍 721 00 Ostrava-Svinov

☎ +420 597 317 665

✉ mercor@mercorgroup-czech.cz

MERCOR - DUNAMENTI TŰZVÉDELEM ZRT.

> Hungary

www.dunamenti.hu

📍 Nemeskéri Kiss Miklós utca 39

📍 2131 Göd

☎ +36 30 919-0542

✉ godcenter@dunamenti.hu

MERCOR FIRE PROTECTION UK LTD

> England

📍 Deanway 2 Suite 1 Ground Floor Wilmslow Road

📍 Handforth, SK9 3FB

☎ +44 (0) 7547 799 189

✉ enquiries@mercorgroup-fp.co.uk