



FIRE VENTILATION SYSTEMS DEPARTMENT

OPERATION AND MAINTENANCE MANUAL

Hybrid smoke prevention
system for evacuation routes

mcr EXi-F



mcr EXi-F 23.07.28.1 version



CONTENTS

1.	INTRODUCTION INTO TRADING	4
2.	FOREWORD	5
3.	OBJECT OF THE DOCUMENTATION	5
4.	INTENDED PURPOSE OF THE DEVICE.....	5
4.1	Application	5
4.2	System elements	5
4.3	System mode of operation	5
4.4	System selection principle	7
4.4.1.	Requirements of the EN 12101-13 standard	8
4.4.2.	Requirements in the Manual no. 378/2002 of the Construction Technology Institute.....	9
4.4.3.	Requirements concerning the design of a fire ventilation system	11
5.	SYSTEM COMPONENTS.....	12
5.1.	Design of the mcr EXi-F air supply unit.....	12
5.1.1.	Fan.....	16
5.1.2.	Shut-off damper (non-insulated/insulated).....	17
5.1.3.	Service disconnecter.....	18
5.1.4.	Vibration and noise dampening elements (optional).....	18
5.1.5.	Installation feet (optional)	19
5.1.6.	LAM louvered vents (optional)	19
5.2.	Explosion pressure relief panels (PL, PLD) and system permanent unsealing module (PRC) (optional).....	20
5.3.	mcr OMEGA control panel	23
5.3.1.	Description and principle of operation	23
5.3.2.	Signaling	25
5.3.3.	Specifications.....	25
5.3.4.	mcr ICR pro positive pressure regulator	27
5.4.	mcr ICS pro differential pressure transmitter.....	28
5.5.	mcr PSR / mcr PSRC manual control panel	30
5.6.	mcr WPS elevated control panel	31
5.7.	Duct smoke detector	32
5.8.	Intake vent switching system.....	33
5.9.	mcr ICP lobby controller	34
5.10.	mcr PP connection box	37
5.11.	Damper for lobby systems	38
5.12.	mcr HT anti-icing system	39
5.13.	mcr SEP network separators.....	41
5.14.	Temperature transmitter.....	42
5.15.	Magnetic sensors (reeds).....	43
5.16.	Differential pressure switch.....	43
6.	ELECTRICAL CONNECTION.....	44
6.1.	Electrical connections of devices to the mcr Omega panel	62
6.1.1.	EXi-F unit air supply fan.....	62
6.1.2.	Service disconnecter.....	63
6.1.3.	Shut-off damper.....	63
6.1.4.	mcr PLD explosion pressure relief panels.....	64

6.1.5. mcr RPC system permanent unsealing module.....	64
6.1.6. Connection of the mcr Omega control panel from FSS.....	65
6.1.7. Connection diagram for automation with backup fan	66
6.1.8. Automation connection diagram for vertical fans.....	67
6.1.9. Automation connection diagram for switching system / double intake vent.....	68
6.1.10. Automation connection diagram for lobby system	68
6.1.11. mcr ICS pro differential pressure transmitter.....	73
6.1.12. mcr PSR / mcr PSRC manual control panel	74
6.1.13. mcr WPS elevated control panel	75
6.1.14. Duct smoke detector	75
6.1.15. mcr HT anti-icing system	76
6.1.16. Connection of mcr EXi-F actuators	76
6.1.16.1. Actuators with return spring.....	76
6.1.16.2. Actuators without return spring	77
6.1.16.3. High-speed actuators for the mcr ICP lobby regulator	77
7. PNEUMATIC CONNECTION.....	77
7.1. Connection of a mcr ICS pro differential pressure transmitter	79
7.2. Connecting the mcr ICP lobby regulator.....	80
8. MECHANICAL CONNECTION OF SYSTEM COMPONENTS.....	81
8.1. mcr Monsun air supply units.....	81
8.2. Control panel mcr Omega	84
8.3. mcr ICS pro differential pressure transmitter.....	84
8.4. mcr PSR / mcr PSRC manual control panel	85
8.5. Duct smoke detector	85
8.6. mcr ICP lobby regulator	86
8.7. mcr PP connection box	86
8.8. Magnetic sensors (reeds).....	87
8.9. Differential pressure switch.....	88
9. ACTIVATION OF THE MCR EXI-F SYSTEM	88
9.1. mcr EXi-F application.....	89
9.2. Commissioning, adjustments, measurements.....	90
9.2.1. Guidelines	90
9.2.2. Most common errors.....	92
10. SYSTEM ELEMENTS MARKING SCHEME.....	96
11. TRANSPORT AND STORAGE CONDITIONS.....	97
12. MAINTENANCE AND SERVICE	98
13. WARRANTY AND GUARANTEE CONDITIONS	98





CAUTION:

- The Company reserves the right to introduce modifications and changes.
- As of the date of issue of the operation and maintenance documentation, the previous version are invalidated.
- The operation and maintenance manual does not apply to devices manufactured prior to its issue date.

1. INTRODUCTION INTO TRADING

The EXi-F hybrid smoke prevention system for evacuation routes has been introduced into trading based on documents issued by the Instytut Techniki Budowlanej (Construction Technology Institute) and a national declaration of performance:

1. National Technical Assessment ITB-KOT-2021/1788 issue 2
2. National Certificate of Constancy of Performance 020-UWB-2469/W
3. National Declaration of Performance HW/01/2021

	<p>INSTYTUT TECHNIKI BUDOWLANEJ CERTIFICATION DEPARTMENT ul. FILTROWA 1, 00-611 WARSZAWA tel.: +48 (22) 57 96 167, +48 (22) 57 96 168 e-mail: certyfikacja@itb.pl, www.itb.pl</p>	
<p>NATIONAL CERTIFICATE OF CONSTANCY OF PERFORMANCE No 020-UWB-2469/W</p>		
<p><small>In compliance with the Ordinance of the Minister of Infrastructure and Construction of 17 November 2016 on the Way of Declaring Performance of Construction Products and Way of Labelling Them with The Construction Mark (Journal of Laws 2016, item 1966, as amended) this certificate applies to the construction product:</small></p>		
<p>Kit of products mcr EXi-F for pressure differentiation in smoke and heat control systems</p>		
<p><small>technical description of the product – as given in pt 1 of ITB-KOT-2021/1788 edition 2 intended use – as given in pt 2 of ITB-KOT-2021/1788 edition 2 performance of the product – as given in pt 3 of ITB-KOT-2021/1788 edition 2</small></p>		
<p>covered by the national technical assessment:</p>		
<p>ITB-KOT-2021/1788 edition 2</p>		
<p>placed on the market under the name or trade mark of:</p>		
<p>„MERCOR” S.A. ul. Grzegorza z Sanoka 2 80-408 Gdańsk Poland</p>		
<p>and produced in the manufacturing plant:</p>		
<p>„MERCOR” S.A. ul. Kwarcowa 3a 83-031 Ciepłowo Poland</p>		
<p><small>This certificate attests that all provisions concerning the assessment and verification of constancy of performance which refer to the performances defined in the aforementioned national technical assessment under national system 1 are applied and that</small></p>		
<p>the producer has implemented the factory production control system to ensure maintaining the constancy of these performances.</p>		
<p><small>Certificate No 020-UWB-2469/W was first issued on 13.06.2019 and preceded by certificate No ITB-2469/W. This certificate (updated on 23.06.2021, 01.08.2022) will remain valid until 28.06.2027 as long as neither the national technical assessment, the AVCP methods, the construction product nor the manufacturing conditions in the plant are modified significantly, unless suspended or withdrawn by the accredited product certification body.</small></p>		
<p>HEAD of the Certification Department</p>  <p>Katarzyna Hatowska, M.Sc. Eng.</p>	 <p>Warsaw, 01.08.2022</p>	<p>DEPUTY DIRECTOR of Instytut Techniki Budowlanej</p>  <p>Anna Panek, M.Sc. Eng.</p>

The validity of this certificate can be authenticated at certyfikacja@itb.pl

2. FOREWORD

The purpose of this operation and maintenance manual is to inform the user about the designated use, design, mode of operation, correct installation and handling of the product. The OMM also contains additional information about the conditions for use, maintenance and guarantee conditions for the product.

Prior to starting installation and operation of the device, this OMM must be reviewed in detail. Failure to follow the recommendations included in the documentation may lead to dangerous situations, damage to property and/or injuries. The manufacturer shall not be responsible for damage resulting from use that is inconsistent with this documentation.

3 OBJECT OF THE DOCUMENTATION

This OMM relates to the entire group of devices constituting the mcr EXi-F hybrid smoke prevention system for evacuation routes. Observing the recommendations included in the OMM shall ensure the correct functioning of the device within the scope of fire protection for rooms and the safety of system users.

4 INTENDED PURPOSE OF THE DEVICE

4.1 Application

The mcr EXi-F system is used to protect any protected area (staircases, elevator shafts, lobbies, evacuation corridors) against smoke by creating overpressure. The system is made up of appropriately configured device sets that cooperate and prevent the penetration of smoke into the protected space by creating higher overpressure. Depending on the individual needs, air supply to the protected space may be ensured using a single-point or multi-point air supply. Device sets are appropriate for indoor and outdoor operation, can operate in a vertical or horizontal fan operating position, depending on the ordered version (installation on roofs, in walls etc.).

4.2 System elements

The mcr EXi-F system includes, but is not limited to elements such as:

- air supply unit(s) with additional equipment (dampers, intake vents, exhaust vents etc.),
- mcr Omega power supply and control panel,
- mcr ICR pressure regulator (mcr Omega panel component),
- mcr ICS and mcr ICP differential pressure transmitter(s).

Auxiliary system components may include:

- mcr PSR manual control panel
- U2 intake vent switching system,
- duct smoke detectors,
- WPS elevated control panel,
- mcr PL and mcr PLD explosion pressure relief panels,
- mcr RPC system permanent unsealing module.

4.3 System mode of operation

Operation of the mcr EXi-F system is controlled by the mcr Omega power supply and control panel. The overpressure system is activated automatically by means of a signal from FSS. Once a signal confirming that a fire was detected in the building is sent, the following activities are performed:

- opening dampers at air supply units,
- opening air exhaust elements for the usable floor space on the level affected by the fire,
- activation of air supply units,

- opening the system permanent unsealing module (if included).

Several seconds after a fire is detected, the protected space is filled with air, creating a pressure difference between this space and the adjacent rooms. The required amount of overpressure is controlled by supplying a variable amount of air to the protected zone using one or more air supply units.

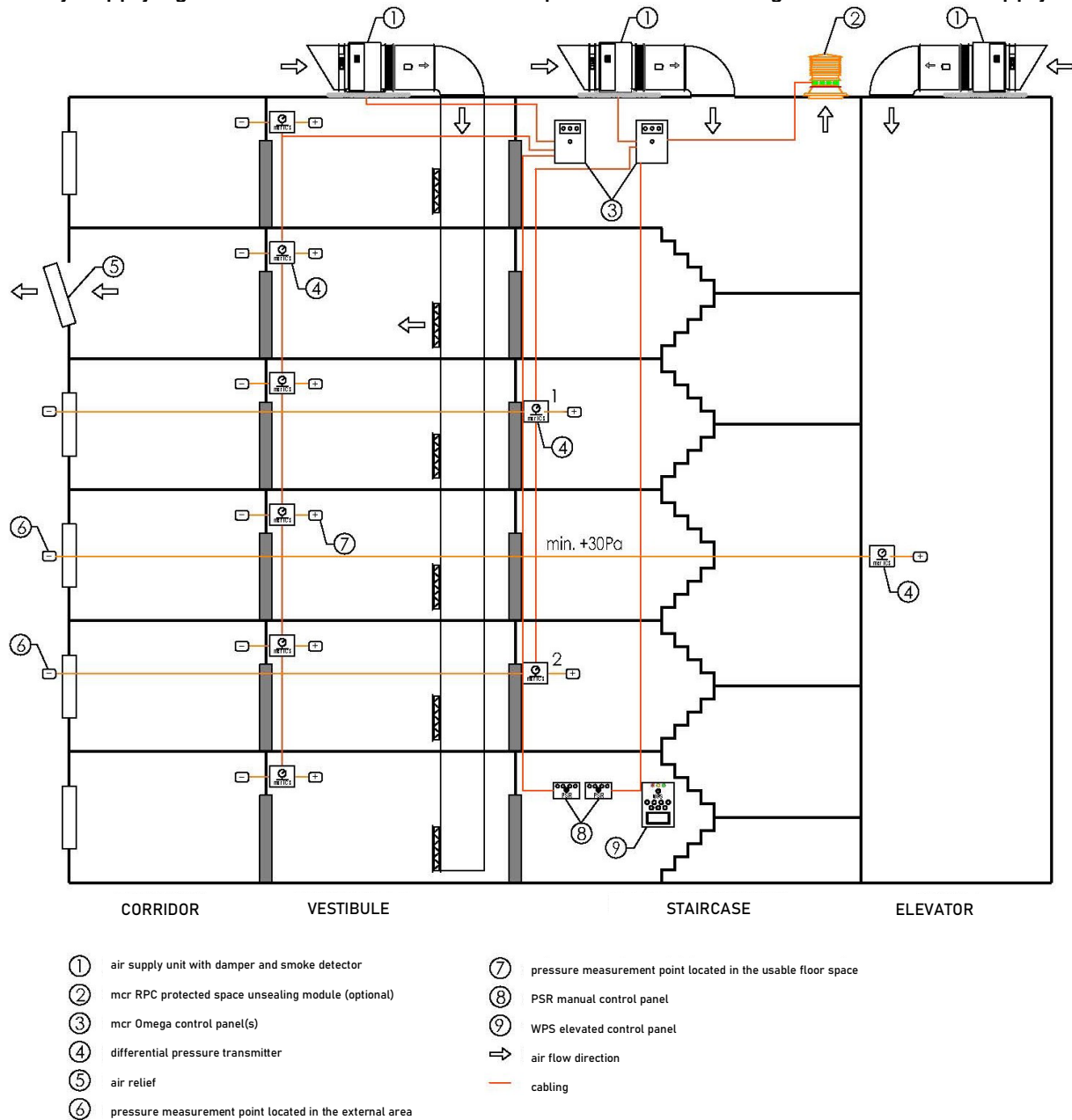

Figure 1 mcr EXi-F system schematic diagram.

Where the door to the protected zone is closed, the fan, which is the main element of the air supply unit, delivers the necessary stable air volume. Measurement and control of the current pressure value in the protected space is ensured via one or more pressure transmitters. The overpressure created in the protected space at the assumed level guarantees that the force necessary to open the evacuation door does not exceed 100 N. Opening the door causes a pressure drop in the protected zone, which increases the fan rpm (system response time below 3 seconds) and ensures the appropriate design air flow value through the open door separating the protected zone from the adjacent space. In order for the required air flow velocity through the open door to achieve the desired value, it is necessary to ensure air relief into the surroundings, e.g. via one or a combination of the following solutions:

- an opening in the external wall (e.g. automatically opened windows – mcr OSO, grilles),
- air vent shaft equipped with fire dampers (e.g. mcr FID S, mcr WIP PRO) at the outlet from each level,

- mechanical exhaust, properly designed and controlled, terminated with a smoke exhaust fan (e.g. mcr Pasat or mcr Monsun).

A shut-off damper is one of the elements of an air supply unit. While the system is in standby, the damper remains closed and prevents the staircase from seeping heat. The damper is opened in case of a fire alarm. The air supply unit system may be additionally equipped with a duct smoke detector. Should the detector identify smoke in the vented air, the fan is stopped and the damper is closed. When the air inlet is located on the roof, according to the guidelines in the standard [1], two opposing intake vents should be used, each equipped with a damper and smoke detector, unless the design stipulates otherwise. Should the smoke detector identify that the air is contaminated with smoke, the intake vent with smoke is shut off and the damper on the opposing air inlet is opened (U2 double intake vent system).

The throughput of the air supply unit that protects a particular space against smoke is determined by the designer. When selecting the air supply unit for each certified overpressure system, check the minimum unit throughput condition. This value determines the minimum required leakage in the protected space to ensure that the system's proper operation conditions are met (maximum reaction time to conditions changing during the evacuation). In protected sealed spaces that require high air supply units throughput values (e.g. staircase with a small number of large doors), the leakage surface may prove to be too small compared to what is required. In such a case the protected area should be additionally "unsealed". The unsealing function may be provided by any opening in the external wall or roof of the space protected against smoke. It is recommended for the unsealing opening to be closed during normal use, to prevent the room from seeping heat, and it should only be opened as a result of a fire alarm.

The following may be used as system unsealing modules in the mcr EXi-F system:

- roof exhaust vent with a multi-blade damper with an mcr RPC fire-rated actuator,
- mcr LAM louvered vent.

Where achieving the required operating parameters of the system is difficult, it is recommended to use mcr PL, mcr PLD explosion pressure relief panels with the appropriate actuation threshold.

4.4 System selection principle

In Poland, the design of systems preventing smoke accumulation in vertical and horizontal evacuation routes is based on the following:

- EN 12101-13 standard "Smoke and heat control systems. Part 13: Pressure differential systems (PDS). Design and calculation methods, installation, acceptance testing, routine testing and maintenance." [1]
- Manual no. 378/2002 of the Construction Technology Institute "Designing fire ventilation systems for evacuation routes in high and high-rise buildings". [2]

The designer is also authorized to design based on his own technical expertise and in agreement with an expert in the field of fire protection they can adopt individual design criteria for a particular building. Irrespective of the technical assumptions made, each of the smoke control systems should ensure the following:

- required overpressure,
- pre-determined minimum air flow velocity in open doors,
- maximum allowed evacuation door opening force.

4.4.1. Requirements of the EN 12101-13 standard

The standard [1] sets apart two pressure differentiation system classes (Class 1 and Class 2) that differ in terms of the design requirements and conditions. The following table presents the typical applications of system classes based on building purpose.

Requirements for the individual types of buildings	
System class	Building type
1	<ul style="list-style-type: none"> in buildings with automatic fast response water sprinkler extinguishing systems with a response time index (RTI) ≤ 50 that are triggered by temperatures ≤ 72 °C or in residential buildings below the limits for tall buildings (in accordance with national requirements) or in residential buildings with at least two areas without fire load between the protected space and the potential fire source and equipped with self-locking doors or if Class 1 was accepted by competent authorities
2	<ul style="list-style-type: none"> if the requirements for Class 1 are not adequate or not applicable or in buildings without automatic fast response water sprinkler extinguishing systems or if required by competent authorities.

Once the proper classification of the building has been determined, a system that would meet the requirements for the particular class is to be designed. The following table presents the design criteria for the individual system classes. These requirements are decisive for the air supply unit throughput.

Parameter	Class 1	Class 2
Door opening force	≤ 100 N	
Pressure difference	≥ 30 Pa	
Airflow velocity	≥ 1 m/s	≥ 2 m/s
Activation time	≤ 60 s	
Operating time	≤ 120 s	
Response time	≤ 5 s	

The designed system should ensure a pressure difference of at least 30 Pa between the protected space and unprotected space on the floor where a fire has appeared. This requirement must be met when:

- all doors in the protected staircase along with the exit doors are closed and
- all doors to the elevator shaft with increased pressure, except for a single access door, are closed and
- the air exhaust vent from the staircase space is open and operational.

Where the doors between the protected space are open, the pressure difference criterion is replaced with air flow criteria, as per the table above. Where more than one door leads from a protected space to an unprotected space, it should be noted that the PDS system will only work with one door fully open, assuming, in the case of doors with different dimensions, that it would be the door with the largest surface area. In the case of double-leaf doors it is assumed that the bigger leaf is open. The velocity criterion should be met on the floor where the fire occurred.

Air supply to the staircase should be distributed evenly over the entire height of the staircase via a vertical shaft. Air supplies should be located at least on every third level, unless the design indicates that a smaller number of supplies will ensure the required throughput. Air supplies should not be located near doors and the air stream velocity should not exceed 5 m/s.

Overpressure in the fire elevator shaft cannot negatively impact its operation. Should smoke penetrate into the common, unprotected hallway, the pressure difference between the staircase and hallway and between the elevator shaft and hallway cannot force the smoke to flow into the staircase or elevator shaft. The above condition may be fulfilled by means of:

- limiting the air supply velocity into the shaft up to a maximum of 3 m/s or
- placing the air inlet in the upper part of the shaft or
- placing the air inlet in the lower possible location.

4.4.2. Requirements in the Manual no. 378/2002 of the Construction Technology Institute

The manual [2] mentions two systems for protecting evacuation routes, designated as solution A and B. These solutions are based on protecting the staircase and smoke-stop lobbies against smoke and ensuring smoke exhaust ventilation for the evacuation corridor.

The table below presents the design criteria for these systems.

Protecting a staircase from against accumulation of smoke	
System class	Conditions
Solution A	The smoke prevention system is to ensure: <ol style="list-style-type: none"> 1. A pressure difference of 20 ÷ 80 Pa between the staircase and corridor, assuming that: <ul style="list-style-type: none"> - all doors between the staircase with increased pressure and the lobbies are closed, - the exit door is closed. 2. Air velocity not less than 0.5 m/s: <ul style="list-style-type: none"> - through the open door of the staircase at the level where the fire occurred, where the smoke-stop lobby door is also open, - through the staircase exit door.
Solution B	As above

Protecting a smoke-stop lobby against accumulation of smoke	
System class	Conditions
Solution A	<ol style="list-style-type: none"> 1. Air supply to the lobby with a throughput of $\geq 720 \text{ m}^3/\text{h}/\text{m}^2$ of the lobby. 2. Mechanical exhaust from the lobby with a throughput of $\leq 90\%$ of the supply. 3. Pressure differentiation in the lobby compared to the staircase and evacuation corridor where the lobby door is closed.
Solution B	<ol style="list-style-type: none"> 1. Air supply to the lobby with a throughput ensuring an air flow velocity through the open lobby door between the lobby and the evacuation corridor at a level of 1.0 m/s (accounting for air supply through the open door between the staircase and lobby). 2. Air flow from the lobby to the corridor via transfer dampers installed in the wall between the lobby and the corridor. 3. Air velocity in the open door between the lobby and the corridor at least 1 m/s while the door between the staircase and lobby is open. 4. Pressure differentiation in the lobby compared to the staircase and evacuation corridor where the lobby door is closed.

Smoke ventilation of evacuation corridors	
System class	Conditions
Solution A	<ol style="list-style-type: none"> 1. Direct air supply to the corridor. Air velocity ≤ 5 m/s. Minimum supply airflow 3600 m³/h. 2. Smoke extraction system throughput $\geq 130\%$ of the supply throughput. 3. Ensuring a distance between the smoke ventilation and air supply grilles as per the ITB Manual.
Solution B	<ol style="list-style-type: none"> 1. Indirect air supply from the lobby to the corridor via a transfer damper in the wall between the lobby and corridor. Air velocity at the damper ≤ 5 m/s. 2. Smoke extraction system throughput $\geq 130\%$ of the supply throughput. 3. Ensuring a distance between the smoke ventilation and air supply grilles as per the ITB Manual.

Protecting an evacuation lobby against accumulation of smoke	
System class	Conditions
Solution A	<ol style="list-style-type: none"> 1. Mechanical exhaust system with a throughput of no less than 3600 m³/h per each 100 m² of the lobby surface area. In no case less than 5400 m³/h. 2. Air supply system depending on the lobby height: <ol style="list-style-type: none"> a) $h \leq 5$ m <ul style="list-style-type: none"> - mechanical air supply, - air supply throughput 30% less than the exhaust throughput. b) $H \geq 5$ m <ul style="list-style-type: none"> - gravitational air supply, - air supply openings size selected based on the flow, no more than 5 m/s at the air supply grille.
Solution B	As above

Protecting an elevator shaft against accumulation of smoke	
System class	Conditions
Solution A	Pressure difference between the emergency services elevator shaft and the usable floor space should be approximately 50 Pa.
Solution B	

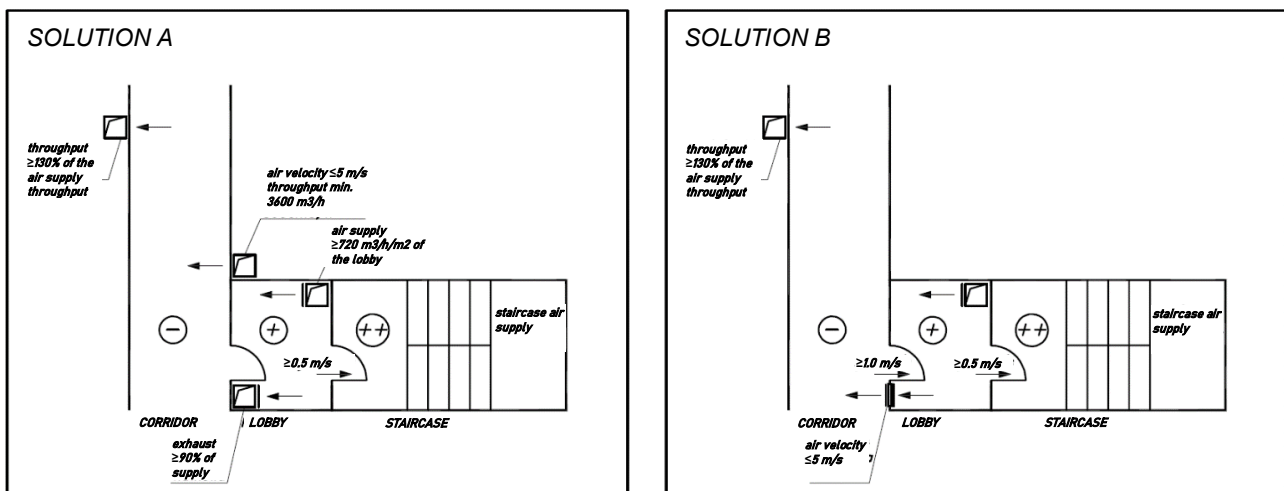

Figure 2 Design requirements diagram for solutions A and B.

4.4.3. Requirements concerning the design of a fire ventilation system

The standard [1] and Manual [2] determine the requirements that a fire ventilation system should meet. The following table presents the basic guidelines that are to be taken into consideration when designing the system.

Air supply points for the staircase		
Condition	PN-EN 12101-13:2022	ITB Manual no. 378/2002
Regardless of building height	Multi-point air supply at least every 3 levels, unless the design indicates that a smaller number of air supply points will ensure the required throughput	Single-point air supply may be used

Air supply points for the elevator shaft		
Condition	PN-EN 12101-13:2022	ITB Manual no. 378/2002
Regardless of shaft height	Single-point air supply may be used	Single-point air supply may be used

Location of the air supply unit		
Condition	PN-EN 12101-13:2022	ITB Manual no. 378/2002
Roof-mounted unit	Two air inlets facing in different directions are necessary (double intake vent system). Every inlet should independently provide full air supply as required by the system. Inlets protected with a damper and equipped with duct smoke detectors. If one inlet is contaminated with smoke, the system switches to the other intake vent. The smoke exhaust vent should be located at least 1 m above the air intake vent, at a distance of at least 5 m.	No requirements determined. A single intake vent is admissible.
Unit on other levels	In the case of wall-mounted intake vents a single air inlet equipped with a damper and duct smoke detector is required.	No requirements determined.

Evacuation of air from the usable floor space in order to ensure air exhaust outside the building		
Condition	PN-EN 12101-13:2022	ITB Manual no. 378/2002
Gravity vent	Windows equipped with automatic control elements, gravitational shafts/ducts may be used	The manual does not include the application of a gravity vent.
Mechanical vent	Active air exhaust, smoke exhaust fan of the proper class may be used.	A mechanical smoke exhaust system is mandatory.

5. SYSTEM COMPONENTS

5.1. Design of the mcr EXi-F air supply unit

mcr EXi-F system air supply units include the following products:

- mcr Monsun E1 fan in a box-type housing
- automation system in the form of a mcr Omega control panel
- multi-blade damper or LAM vents with actuator
- flexible connection (optional)
- duct smoke detector (optional)
- service disconnecter (optional)
- anti-icing system (optional).

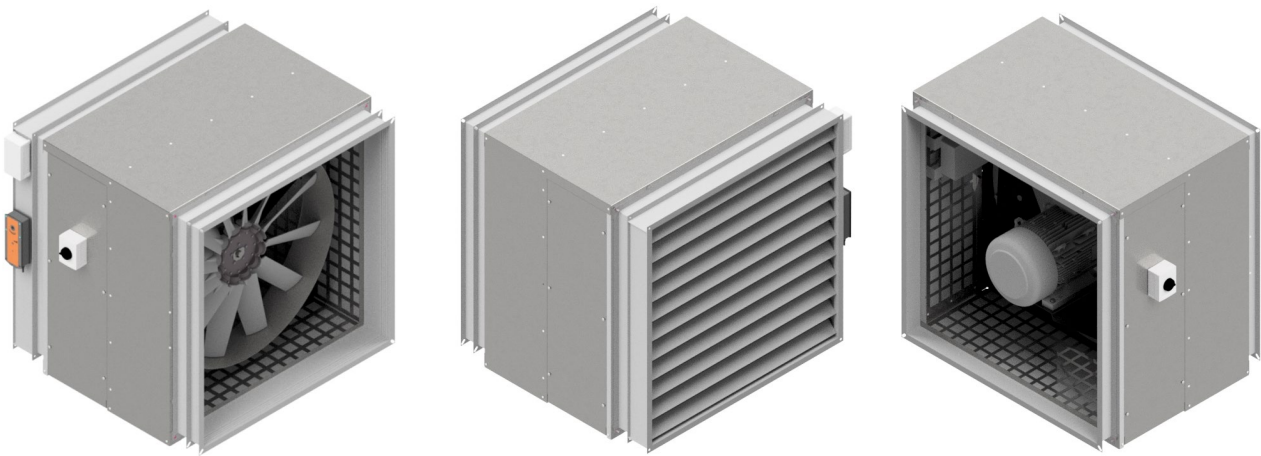

Figure 3 Design of the mcr mcr EXi-F air supply unit (horizontal version).

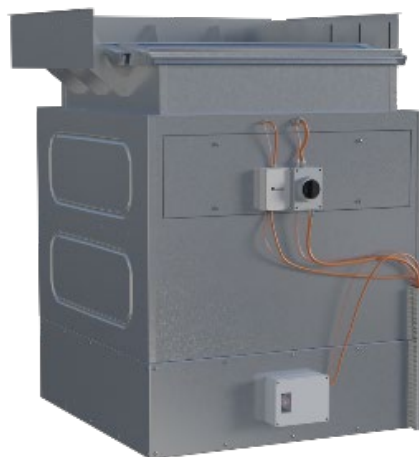

Figure 4 Design of the mcr mcr EXi-F air supply unit (UP vertical version).

Figures 5 to 10 present the installation of sample air supply installations for mcr EXi-F systems.

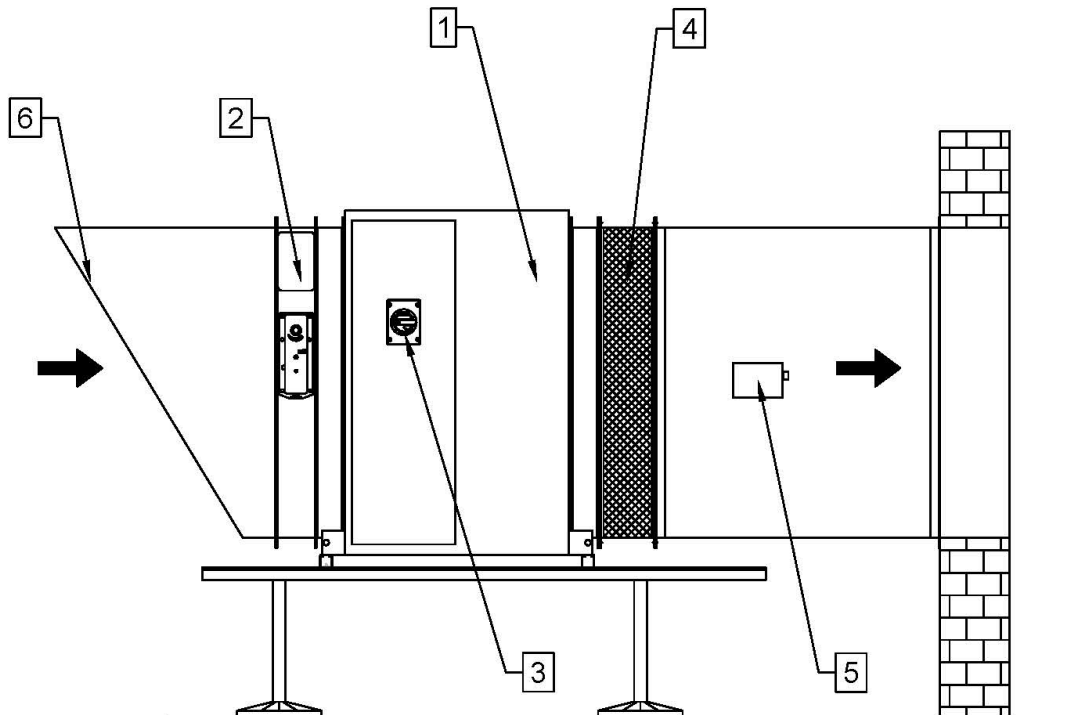

Figure 5 Sample installation of an air supply kit for the mcr EXi-F system: 1 - fan, 2 - damper with actuator, 3 - service disconnect or connection box, 4 - flexible connection, 5 duct smoke detector, 6 - inlet nozzle with grate.

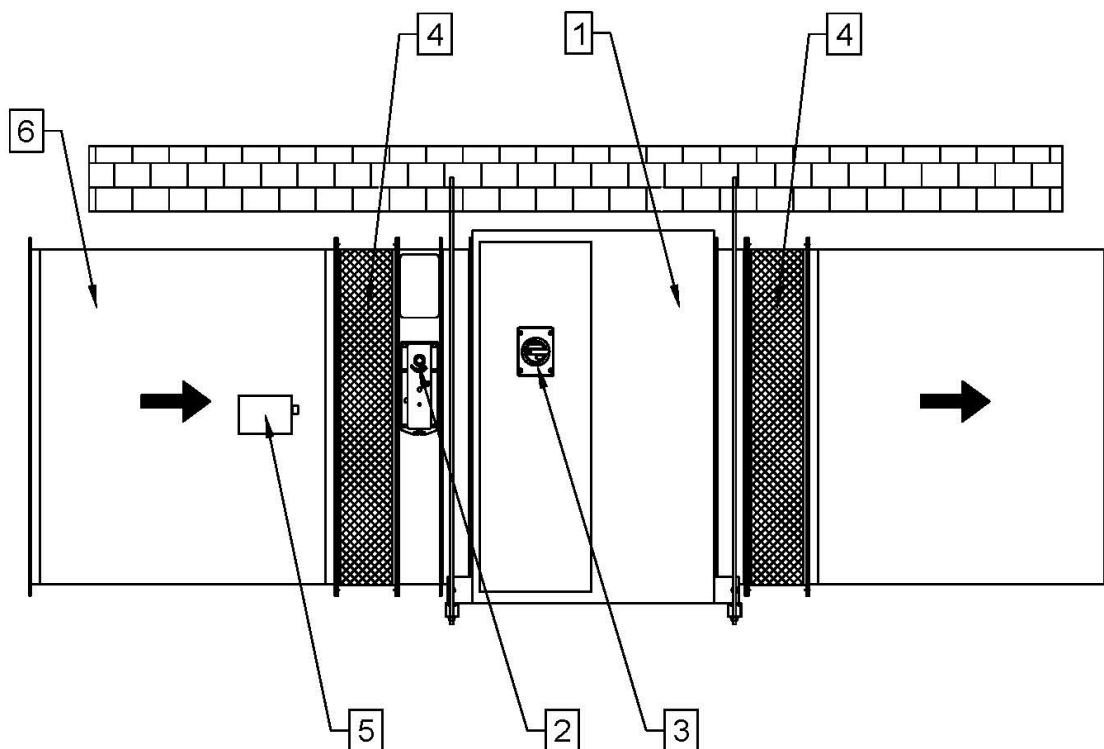

Figure 6 Sample installation of an air supply kit for the mcr EXi-F system in the duct version: 1 - fan, 2 - damper with actuator, 3 - service disconnect or connection box, 4 - flexible connection, 5 duct smoke detector.

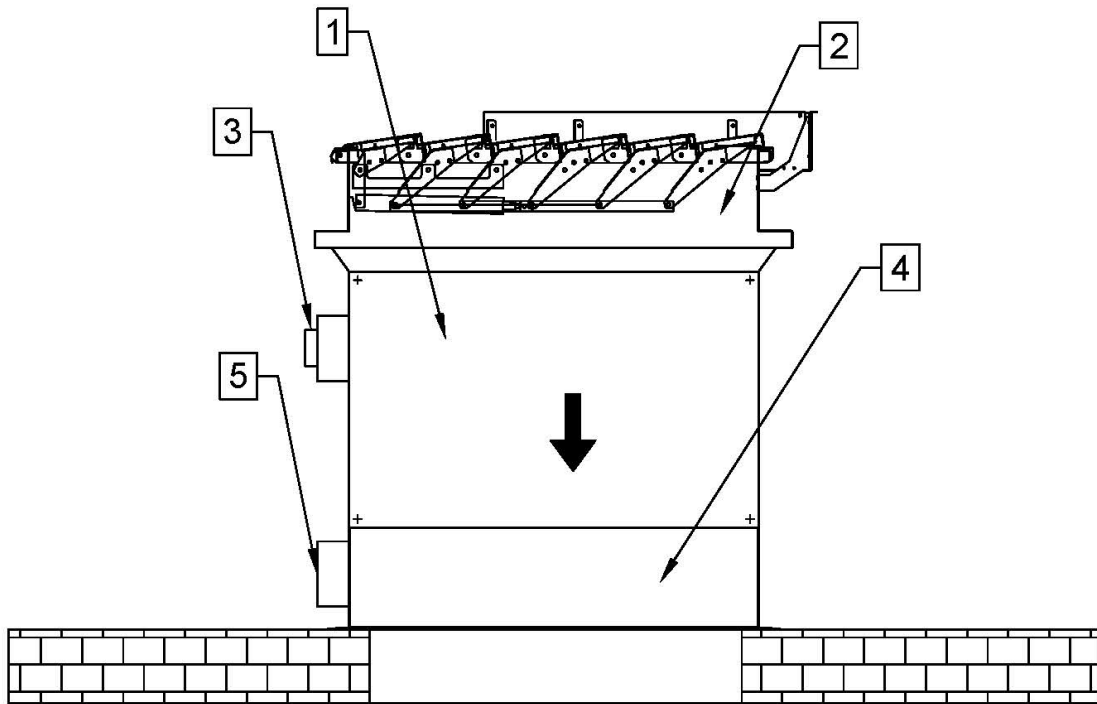

Figure 7 Sample installation of an air supply kit for the mcr EXi-F system in the UP version on the roof: 1 - fan, 2 - LAM vent with actuator, 3 - service disconnecter or connection box, 4 - roof base, 5 - duct smoke detector.

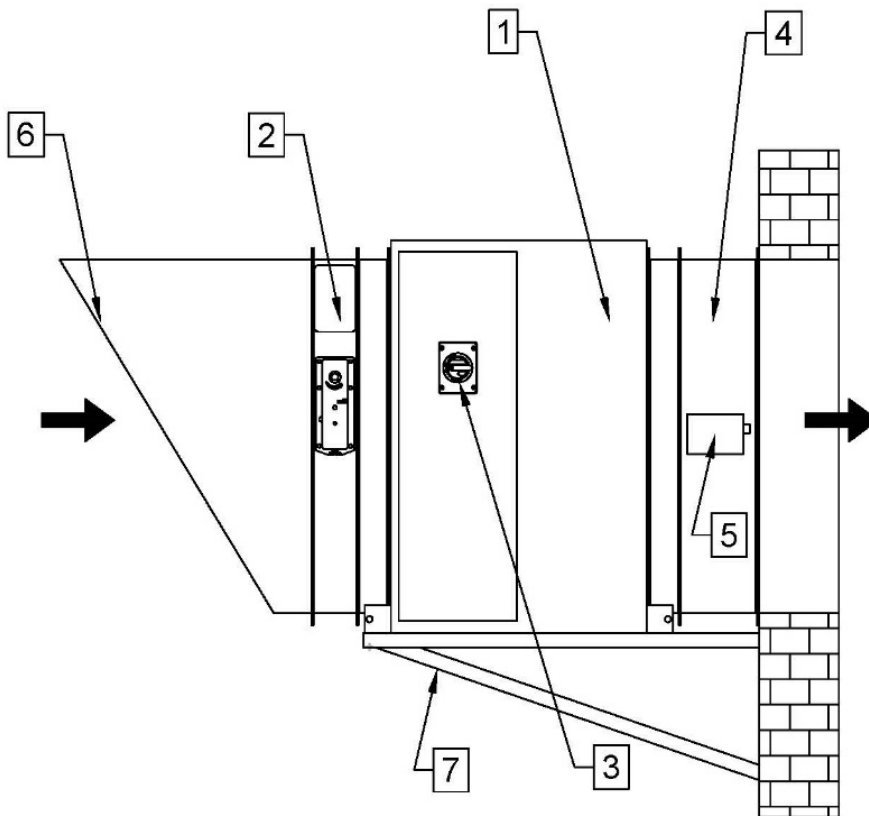

Figure 8 Sample installation of an air supply kit for the mcr EXi-F system in the wall-mounted version indoors: 1 - fan in a box-type housing, 2 - damper with actuator, 3 - service disconnecter or connection box, 4 - lead, 5 - duct smoke detector, 6 - inlet nozzle with grate, 7 - supporting structure.

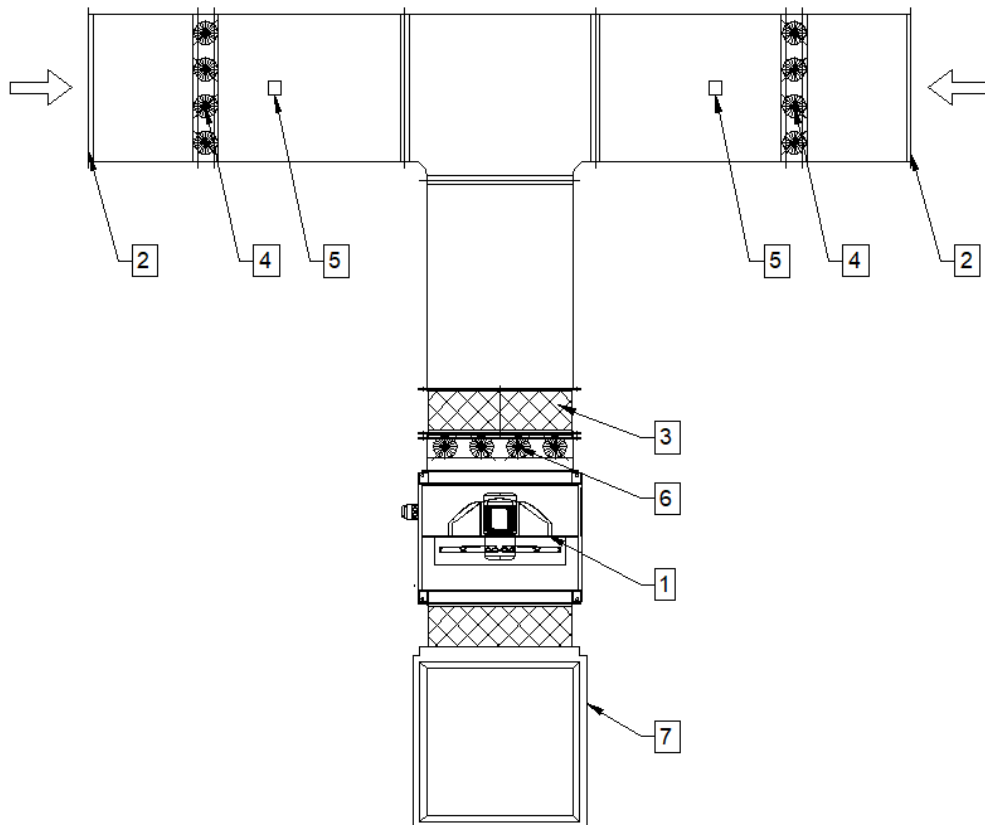

Figure 9 Sample installation of an air supply kit for the mcr EXi-F system in the roof-mounted version with a double air intake vent system: 1 - fan, 2 - intake vent, 3 - flexible connection, 4 - dampers with actuators in a double intake vent system, 5 - duct smoke detector, 6 - shut-off damper, 7 - ventilation duct.

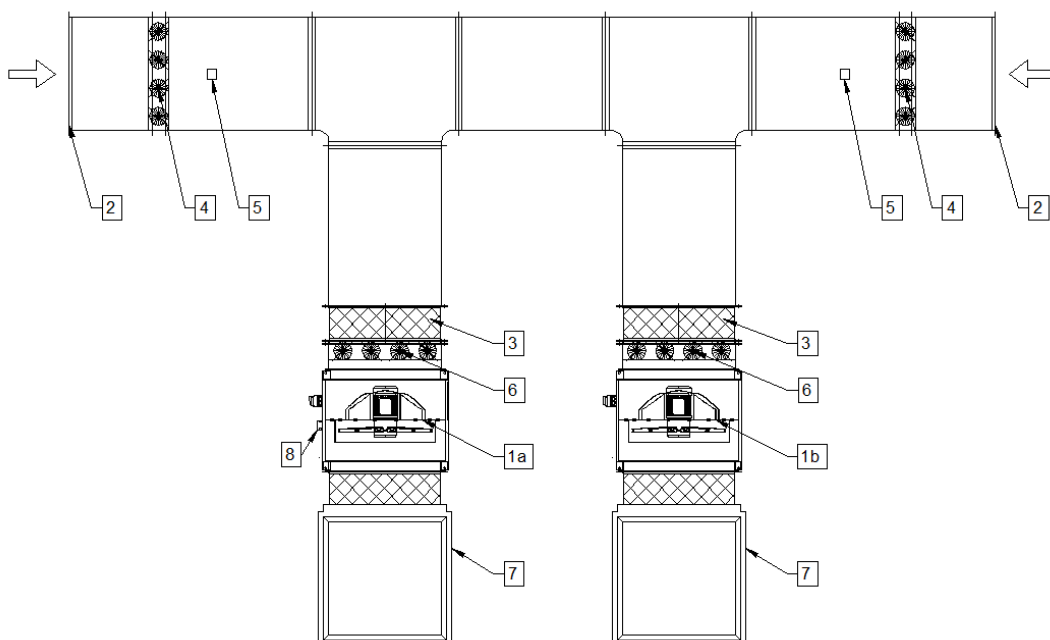

Figure 10 Sample installation of an mcr EXi-F air supply unit on the roof with a back-up unit: 1a - air supply unit basic fan, 1b - air supply unit back-up fan, 2 - intake vent, 3 - flexible connection, 4 - dampers with actuators in a double intake vent system, 5 - duct smoke detector, 6 - shut-off damper, 7 - ventilation duct, 8 - pressure switch.

5.1.1. Fan

The mcr EXi-F system air supply units rely on the mcr Monsun E1 fans. Their task is to transport an appropriate volume of air to ensure that the design requirements are met.

Fans may be installed indoors or outdoors, with the engine in a horizontal or vertical position. Air supply fans are delivered in a box-type housing version. In order to ensure thermal insulation and reduce noise emissions during fan operation, the housing is made of steel metal sheets with an internal layer of mineral wool.

List of hydraulic parameters of mcr EXi-F system components

NO.	System type	Fan type	Power [kW]	Throughput with static pressure [m3/h]	
1	mcr EXi-F 100-1S	mcr Monsun E1 100-4T-20	15	64500/200Pa	20150/700Pa
2	mcr EXi-F 100-2S	mcr Monsun E1 100-4T-15	11	60000/200Pa	40000/490Pa
3	mcr EXi-F 90-1S	mcr Monsun E1 90-4T-10	7.5	45900/200Pa	20000/580Pa
4	mcr EXi-F 90-2S	mcr Monsun E1 90-4T-7,5	5.5	40200/200Pa	13300/600Pa
5	mcr EXi-F 80-1S	mcr Monsun E1 80-4T-5,5	4	30500/200Pa	16000/450Pa
6	mcr EXi-F 71-1S	mcr Monsun E1 71-4T-4	3	22000/200Pa	9000/350Pa
7	mcr EXi-F 71-2S	mcr Monsun E1 71-4T-1,5	1.1	11500/200Pa	8000/260Pa
8	mcr EXi-F 63-1S	mcr Monsun E1 63-4T-1,5	1.1	9200/200Pa	6000/240Pa

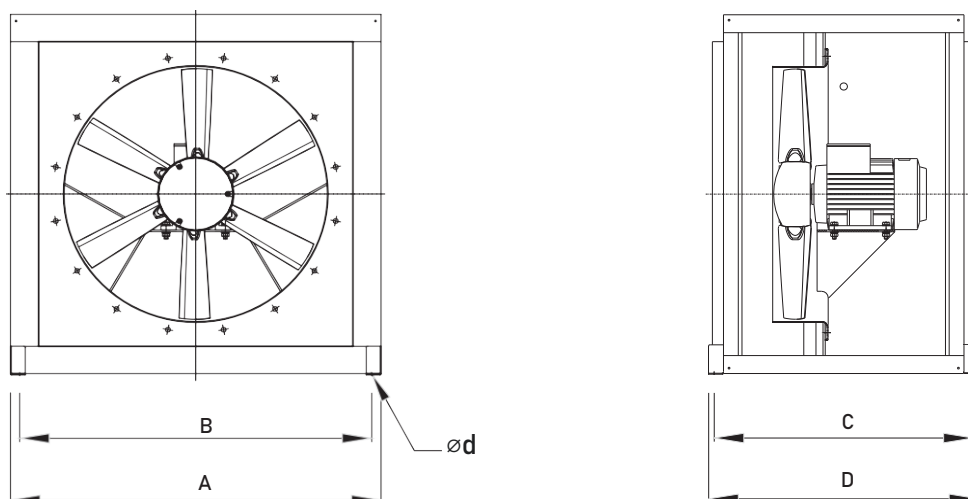

Figure 11 Installation dimensions of mcr EXi-F system air supply unit fans.

System type	A [mm]	B [mm]	C [mm]	D [mm]	d [mm]	Approx. weight [kg]
mcr EXi-F 100	1200	1150	860	884	13	205
mcr EXi-F 90						155
mcr EXi-F 80	1000	950	760	784	13	105
mcr EXi-F 71						90
mcr EXi-F 63	825	775	660	684	13	62

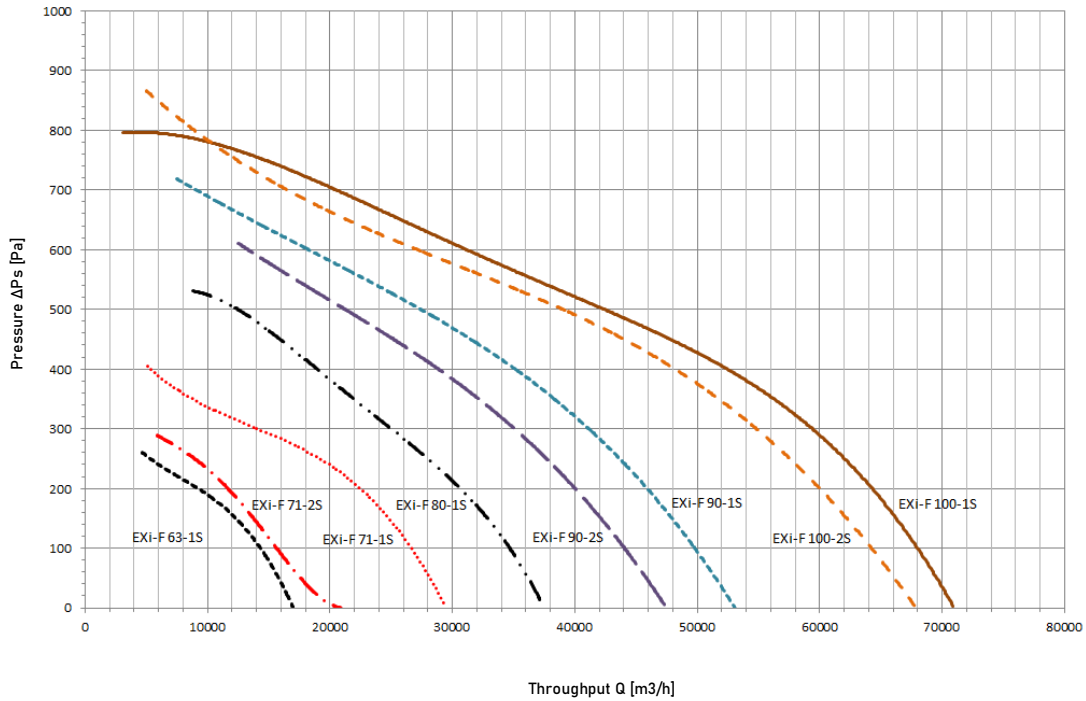

Figure 12 Parameters of standard EXi-F equipment.

5.1.2. Shut-off damper (non-insulated/insulated)

Air supply units of the mcr EXi-F system may be equipped with BLF / BF / BFL / BFN / NF / SF or MF / MLF shut-off dampers with actuator (voltage disconnection opens the damper). The damper rotating mechanism consists of bearings and cogs hidden inside the profile. Dampers are made of aluminum and optionally the dampers may be provide in an insulated version.

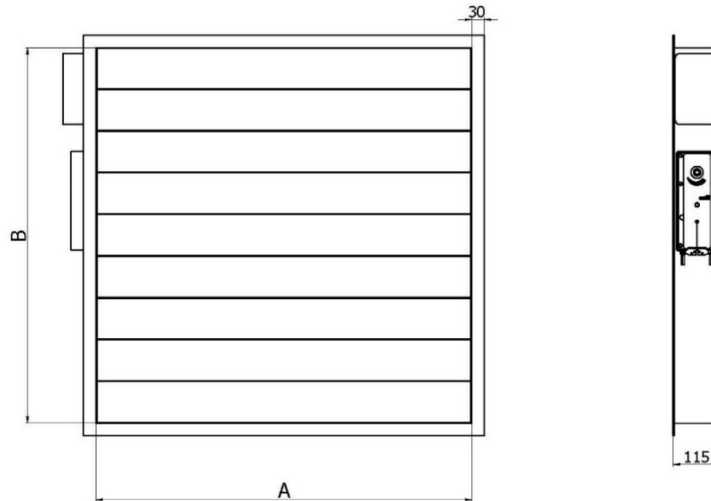

Figure 13 Overview of a shut-off damper.

Dimensions of a shut-off damper depending on kit size		
Product type designation	A [mm]	B [mm]
mcr EXi-F 100	1100	1114
mcr EXi-F 90	1100	1114
mcr EXi-F 80	900	914
mcr EXi-F 71	900	914
mcr EXi-F 63	700	714

5.1.3. Service disconnecter

A service disconnecter may be installed on the housing of the mcr Monsun E1 fan. If the mcr EXi-F air supply unit is ordered with a service disconnecter, the electric wiring will be routed from the disconnecter to the engine connection box at the factory.

For the duration of service works, disconnecter activation may be blocked using a padlock.

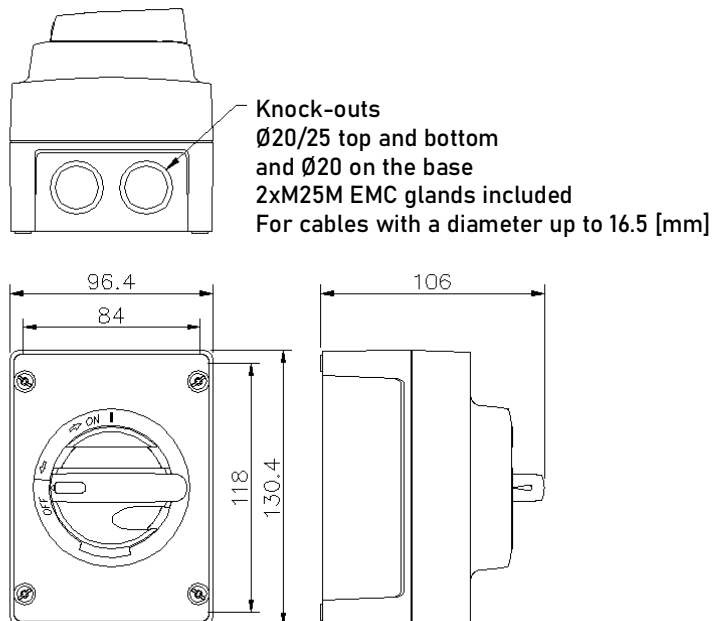

Figure 14 Overview of the service disconnecter.

5.1.4. Vibration and noise dampening elements (optional)

When installing the air supply unit horizontally indoors or outdoors, the fan may be equipped with optional vibration dampers or a vibration dampening mat on the installation profiles (not included in the delivery).



Figure 15 Vibration damper overview.

A flexible connection is used to eliminate vibrations transferred by the fan onto the ventilation system, acting as a vibration damper.



Figure 16 Overview of a flexible connection.

5.1.5. Installation feet (optional)

When installed horizontally indoors, the unit is attached onto a supporting structure and connected, depending on the design requirements, e.g. with the air supply system.

Installation feet are intended for placing the system on a roof.

The attachment system has been designed to support the installation of all types of devices on flat building roofs. It provides a secure system for installing devices.



Figure 17 Attachment system overview.

5.1.6. LAM louvered vents (optional)

The mcr EXi-F may include a mcr LAM louvered vent that enables the following:

- evacuation of air or smoke from a building,
- providing air intake vent functionality for the air supply unit with a horizontal air inlet,
- providing the functionality of unsealing the protected space,
- providing the functionality of an air intake vent in the horizontal and vertical position, as well as in sloped roofs.

mcr LAM louvered vents have been designed to ensure that the manner of removing water from their surface guarantees high leak tightness parameters regardless of the device installation position (starting from installation on flat roofs, through roofs with any slope up to facades and building walls). The declared parameters and properties of the mcr LAM vent, according to the order specification (e.g. snow load category up to SL1300, wind resistance category up to WL4000), ensure operational stability under adverse weather conditions.

mcr LAM louvered vents are the perfect choice for pitched roof slopes, where the installation of a typical intake vent and exhaust vent is not allowed.

The vent's operational reliability is 10 000 ventilation position open/close cycles. Maximum vent opening time to reach the operating position is 60 seconds.

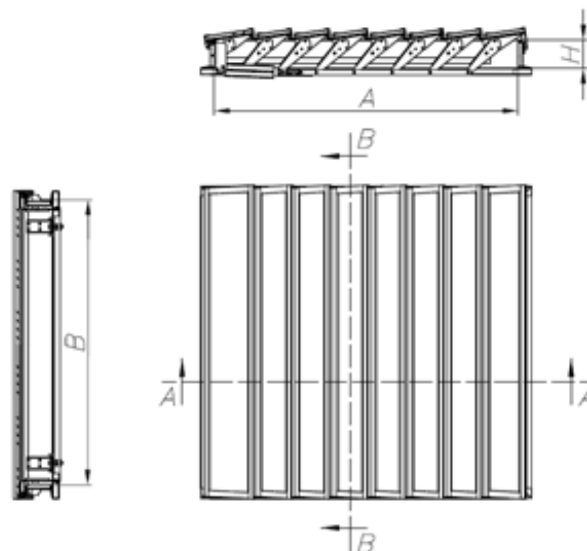

Figure 18 LAM louvered vent overview.

mcr LAM louvered vents are available in the following sizes:

- width: from 800 mm to 3800 mm (at 200 mm intervals)
- length: from 500 mm to 2500 mm (at 100 mm intervals)
- standard vent base height H: 150–250 mm

mcr LAM vent specification			
Vent sealing variant	Standard	D05/D07 option	IP 42 option
Vent actuator supply voltage	24VDC		
Actuator current consumption	0.8 A for SL00, 0,8..3 A for SL250..SL950		
Operational reliability under low temperatures	Up to -25°C		
Resistance to high temperatures	Up to 300°C		
Degree of protection as per DIN EN 60 529	IP40	IP54	IP42

5.2. Explosion pressure relief panels (PL, PLD) and system permanent unsealing module (PRC) (optional)

Explosion pressure relief panels in the mcr EXi-F system may be used as an additional air relief from the protected space in cases where it is more difficult to ensure the required system operating parameters. Explosion pressure relief panels are normally closed. They open as a result of pressure increase in the protected space above a threshold, leading to pressure equalization. Once the pressure in the protected space drops, dampers automatically return to their closed position. The mechanical operation and design of the dampers ensures an operating time of less than 1 second. Dampers are able to operate within a pressure range of 20-80 Pa.

mcr PL dampers are appropriate for wall installation, while mcr PLD dampers are adjusted for roof installation.

mcr PL and mcr PLD dampers may be equipped with shut-off dampers actuated via the mcr Omega panel, depending on the system activation scenario adopted. When the system is inactive, vent blades remain closed. They are equipped with actuators with a return spring. If emergency activation is required, the blades open, allowing the explosion pressure relief panels to work.

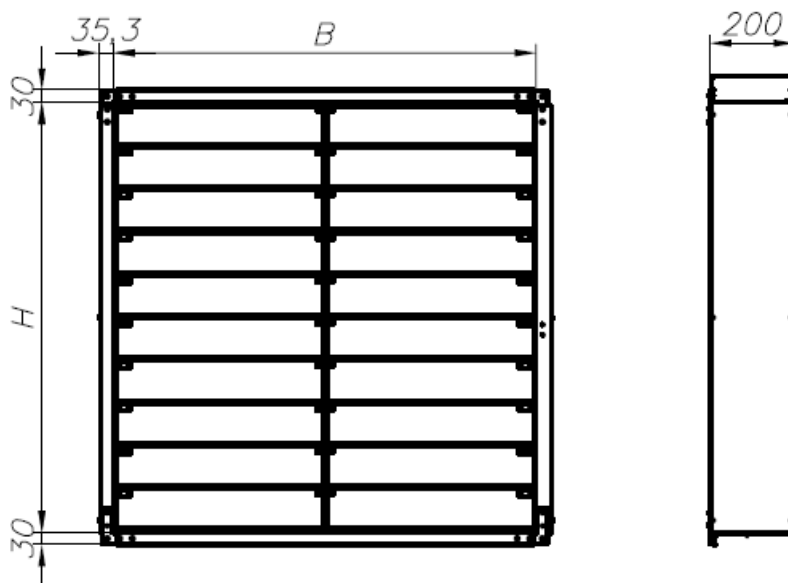

Figure 19 Overview of the PL explosion pressure relief panel.

Basic dimensions and throughput [m3/h] of the mcr PL explosion pressure relief panel									
Height A [mm]	Width B [mm]								
	500	600	700	800	900	1000	1100	1200	1300
500	4050	4880	5700	6500	7300	8150	9000	9800	10,600
600	4880	5860	6800	7800	8800	9800	10,800	11,800	12,700
700	5700	6800	8000	9100	10,300	11,400	12,500	13,700	14,800
800	6500	7800	9100	10,500	11,700	13,000	14,350	15,600	16,900
900	7300	8800	10,300	11,700	13,200	14,700	16,100	17,600	19,000
1000	8150	9800	11,400	13,000	14,700	16,300	17,900	19,500	21,150
1100	9000	10,800	12,500	14,350	16,100	17,900	19,700	21,500	23,300
1200	9800	11,800	13,700	15,600	17,600	19,500	21,500	23,500	25,400
1300	10,600	12,700	14,800	16,900	19,000	21,150	23,300	25,400	27,500

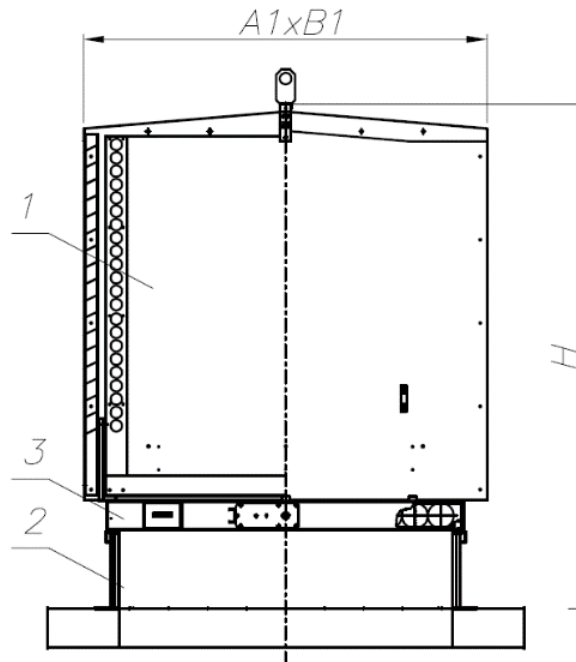

Figure 20 Overview of the PLD explosion pressure relief panel: 1 - vent, 2 - base, 3 - damper with actuator.

Basic technical parameters of the mcr PLD explosion pressure relief panel					
Base inside dimensions	Total dimensions	Damper	Roof base	Maximum vent with 50 Pa	Scale
<i>AxB [mm]</i>	<i>A1xB1xH [mm]</i>	<i>thickness [mm]</i>	<i>height [mm]</i>	<i>[m3/h]</i>	<i>[kg]</i>
1300x1300	1580x1490x1975	125	300	22,000	315
800x800	1170x1080x1525	125	300	13,000	129

As standard, devices are equipped with multi-blade dampers with an actuator, which are used as elements that counteract the free flow of air while the devices are not in operation. The kit may also be equipped with anti-icing systems.

The protected space mcr RPC unsealing module is designed for use in sealed spaces protected with an overpressure system. The mcr RPC unsealing module eliminates pressure hikes in the protected space that occur during evacuation as a result of closing doors. mcr RPC includes the following elements: roof exhaust vent, multi-blade damper with a 24 V actuator and a roof base.

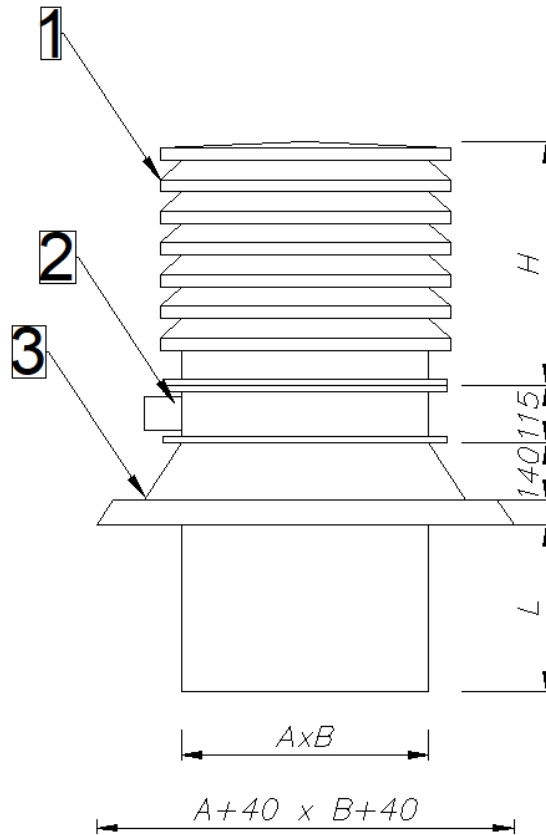

Figure 21 Detailed view of the RPC protected space unsealing module. 1. exhaust vent, 2 damper with BFN actuator, 3 roof base.

The mcr RPC protected space unsealing module is available in two sizes: 600x600 mm and 800x800 mm.

mcr RPC basic dimensions				
Size	A [mm]	B [mm]	H [mm]	L [mm]
600x600	600	600	485	1000 (standard)
800x800	800	800	595	1000 (standard)

5.3. mcr OMEGA control panel



5.3.1. Description and principle of operation

mcr EXi-F pressure differentiation systems rely on an mcr OMEGA panel, adjusted for digital pressure control or ensuring a steady flow rate.

Digital pressure control is ensured via the predictive mcr ICR Pro regulator, which ensures appropriate adjustment of the system operating parameters to varying evacuation conditions. The control panel is designated for providing supervision and controlling the operation of the mcr EXi-F pressure differentiation system elements. This device executed the necessary control and regulation procedures for the pressure difference system preventing the accumulation of smoke, including the time control function of smoke exhaust fans. Moreover, the panel may also be used as a controller for fire divisions. All the features related to overpressure and separation are controlled from this panel. The automation system implemented allows for ensuring powers supply, control, monitoring and visualization of the operating condition of all devices included in the mcr EXi-F smoke accumulation prevention system.

Main tasks of the automation systems include:

- ensuring power supply, control and supervision over the operation of air supply fans used to generate overpressure, depending on the signals from the fire alarm control panel (FSS);
- ensuring power supply, control and supervision over the operation of regulation and shut-off dampers used in air supply fans – the panel provides power supply to the dampers;
- ensuring power supply and handling of duct smoke detectors (optional);
- ensuring power supply and supervision over the operation of vents that are decisive for the proper system operation.

An uninterruptible power supply of 3x400 V is supplied to the control panel. The panel is supplied from a bay designated for fire protection equipment, which is not disconnected when the fire safety switch is activated, an optional automatic transfer switch is available for facilities where the main building switchboard does not have a separate bay for supplying fire protection equipment.

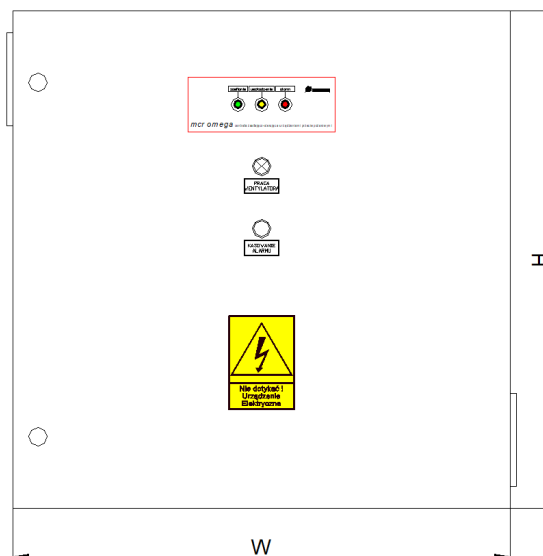

Figure 22 mcr Omega control panel overview.

Dimensions (standard version) of mcr Omega control panels			
mcr Omega control panel type	Width W [mm]	Height H [mm]	Depth [mm]
63.1	800	600	250
71.1	800	600	250
71.3	800	600	250
80.4	800	800	250
90.5	800	800	250
90.7	800	1000	300
100.11	800	1000	300
100.15	800	1000	300

The mcr OMEGA control panel is manufactured and delivered depending on the needs and requirements of the user in steel or stainless steel housings with IP 55, versions for indoor or outdoor use, environmental class III. As a standard, the mcr OMEGA control panel housing is provided with a door placed on the front, equipped with a seal and lock(s) with key. Depending on the version, a cover with glands for introducing electrical wiring inside the equipment is attached at the top or bottom. The number of glands and their distribution results from the system size and the number of external devices that are supplied and controlled. Dimensions and outline dimensions are variable within the range between 600x400x300 and 1200x1200x300 mm and result from the number of devices controlled and the level of complexity of the operations carried out and the “switching program”. A visualization panel is installed on the door, which includes indicators that provide an overview of the device’s power supply status, faults and FSS alarm.

Components of the control panel, depending on the system size, include: automation and control block based on mcr ICR pro controllers, mcr OMEGA panel power supply block (buffer power supply unit with batteries), frequency converters (inverter), overcurrent protection device and contactors. The panel ensures loop checking for the fan power supply line also during outages resulting from a break or short-circuit.

Activation of the emergency control procedure on the mcr OMEGA panel results from receiving a “volt-free” FSS input signal. Panel inputs and outputs (all lines) are monitored in a continuous manner for disruptions, short-circuit and activation time parameters of connected equipment. Signal states are displayed on the controller via LEDs.

5.3.2. Signaling

The panel signals the following operating conditions:

- monitoring (green),
- fire alarm (red),
- blocked (blinking yellow),
- fault (solid yellow).

5.3.3. Specifications

mcr OMEGA control panel specification

Basic supply voltage	400V AC +10%. -15%, 50Hz
Panel working voltage	22.5 V32 V AC(24 V at 200C)
Backup power supply source*	Facility backup power source Certified fire power supply units Internal automatic transfer switch (optional)
Panel monitoring inputs from the mcr MMS PRO module [detecting break, short-circuit, loop checking]	24 V AC with optoelectronic isolation
Panel power supply and control outputs from the mcr MMS PRO module	I _o =4A , 250V AC, 25V DC
Maximum actuators current consumption per single mcr MMS PRO module	20A
Battery Capacity	2,2Ah-40Ah
Alarming organization	1 level (2nd level)
Housing ingress protection	IP 55
Environmental class	III (extended temperature range to -25°C)
Operating temperature range	-25°C +75°C
Relative Humidity	90%
Housing Material	Powder-coated steel or stainless option
Dimensions (H x W x D)	Type series: 300x200x150 600x400x200 800x600x300 800x800x300 800x1000x300 800x1200x300 1000x600x300 1000x800x300 1000x1000x300 1000x1200x300 1200x1000x300 1200x1200x300
Panel operation program	Variable, depending on the needs resulting from the building's fire scenario

/ - for power supply and control of smoke control equipment and fire divisions, the proper operation of which requires backup power supply according to regulations.*

List of product (component) types depending on system configuration		
Product type designation	Fan	Control board
mcr EXi-F 100-1S	mcr Monsun E1 100-4T-20	mcr OMEGA 100.15
mcr EXi-F 100-2S	mcr Monsun E1 100-4T-15	mcr OMEGA 100.11
mcr EXi-F 90-1S	mcr Monsun E1 90-4T-10	mcr OMEGA 90.7
mcr EXi-F 90-2S	mcr Monsun E1 90-4T-7,5	mcr OMEGA 90.5
mcr EXi-F 80-1S	mcr Monsun E1 80-4T-5,5	mcr OMEGA 80.4
mcr EXi-F 71-1S	mcr Monsun E1 71-4T-4	mcr OMEGA 71.3
mcr EXi-F 71-2S	mcr Monsun E1 71-4T-1,5	mcr OMEGA 71.1
mcr EXi-F 63-1S	mcr Monsun E1 63-4T-1,5	mcr OMEGA 63.1

mcr Omega control panel - designation				
Unit size	driving power [kW]	panel symbol	additional function	description
100	15	100.15	Z	external
100	11	100.11	R	backup
90	7.5	90.7	A	emergency automatic transfer switch
90	5.5	90.5	P	double
80	4	80.4	L	LAM vent (vertical)
71	3	71.3	S	meshed
71	1.1	71.1	spec	special
63	1.1	63.1		

Examples are:	Panel:
100.15	basic
100.15 Z	external
63.1 R	basic, backup
100.11 ZR	external, backup
100.15 ZP	external, double
71.3 ZRP	external, backup, double
80.4 L	basic, LAM vent
100.15 A	basic, emergency automatic transfer switch
90.7 ZRA	external, backup, emergency automatic transfer switch
90.5 spec	basic, special version

The mcr Omega control panel uses 2x12 V, 15 Ah batteries.

CAUTION:

Do not leave batteries connected without a main power supply source for the mcr Omega control panel, as this will discharge the batteries (replacement not covered by the guarantee).

5.3.4. mcr ICR pro positive pressure regulator

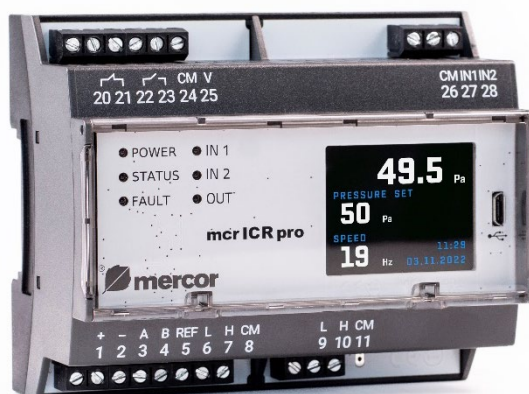

The regulator for smoke and heat control systems is an element of the mcr Omega panel that controls the rpm of the fan via a three-phase frequency converter in order to maintain the desired constant positive pressure value (20-80 Pa) in the protected zone (the device is located in the mcr Omega control panel). The measured pressure value is transferred to the regulator via a distributed network from the mcr ICR pro differential pressure sensor.

In order to determine the object model, the regulator uses an algorithm that allows for precise control in an environment with parameters that are unknown or cannot be determined. Moreover, a predictive algorithm allows to estimate the potential changes for the object in the future, allowing for a dynamic response to an increase of the error between the target and actual value. The mcr ICR pro regulator is installed directly onto a DIN rail in the mcr Omega panel.

It has an integrated display that presents the following information:

- current pressure value in the protected space,
- current fan operating frequency (Hz),
- current errors,
- basic equipment configuration information.

mcr ICR pro regulator technical parameters

Power supply	24±15% [V], AC/DC
Protection	Internal polymer fuse, 200 [mA]
Operating temperature	-25÷55 [°C]
Housing ingress protection	IP30
Installation	DIN rail
Connections	Terminals
Maximum conductor diameter	1.5 [mm ²], max 1 conductor for 1 terminal
Connection of pressure sensors	Differential interface, distributed loop system, galvanically isolated
Inverter connection	Analog signal 0 - 10 [V] or 4-20 mA
BMS connection	Modbus RTU communication, differential interface, galvanically isolated RS485 driver
PC connection	Galvanically isolated USB port
Real-time clock	Yes, battery backup
Digital inputs	2 pcs. - monitored
Relay outputs	2 pcs. - 250 [V]. 2 [A]

For one mcr ICS pro regulator. Communication between system components is ensured via the mcr BUS, which provides high throughput and a high level of security. mcr BUS is a multi-master bus, which in practice means that each device connected to the bus is able to send data at any time, so that individual transmitters can immediately inform the controller that a fault has been detected or an alarm signal has been received.

Components are connected in a loop, which guarantees correct operation of the entire system in the event of a single communication cable failure. Line continuity is monitored on an ongoing basis. Pressure converters periodically send information about their status to the regulator, which allows ongoing monitoring of the system status and detecting faults such as:

- lack of line continuity,
- removal of the mcr ICS pro digital pressure transmitter or its failure,
- lack of alarm input continuity in mcr ICS pro,
- failure of the digital pressure sensor in mcr ICS pro.

5.4. mcr ICS pro differential pressure transmitter



The device is used to measure the differential pressure in a space protected by increased pressure (staircases, elevator shafts or smoke-control lobbies). Two pressure lines should be connected to the device. The measurement results are transferred in real-time through the digital interface of the regulator that controls fan operation (via the inverter).

The mcr ICS pro pressure transmitter offers easy wiring connection inside the housing, using additional multi-channel bushings allows installation directly where the wiring exits the wall. Another benefit is the separate connection of the mcr BUS loop ends (Loop I, Loop II). This increases the speed of connecting the mcr BUS to the network. The use of dedicated mcr BUS communication reduces errors compared to competitor solutions.

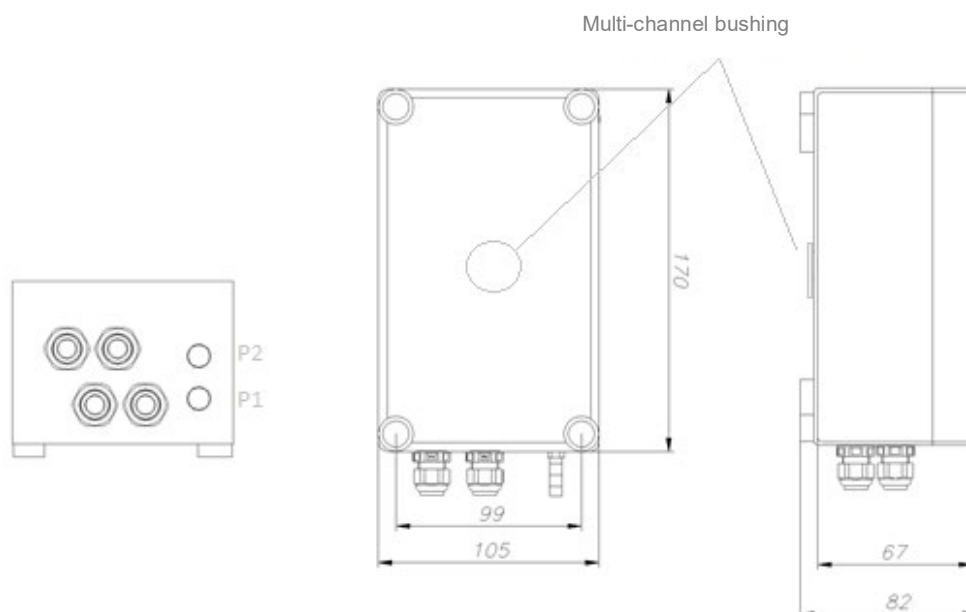

Figure 23 mcr ICS pro digital pressure transmitter - overview.

The device offers two inputs that receive silicone pneumatic hoses leading to zones where the pressure difference is to be measured. These are marked on the PCB cover as P1 and P2.

- P1 - non-inverting input, by default connected to the pressure value for the object where positive pressure is to be created,
- P2 - inverting input, default reference pressure.

mcr ICS pro pressure transmitter specification	
Power supply	24±15% [V], AC/DC
Protection	Internal polymer fuse, 140 [mA]
Operating temperature	-25÷55 [°C]
Housing ingress protection	IP44
Dimensions	198 mm x 105 mm x 82 mm
Installation	To a flat surface, using 2 screws
Cable bushings	Cable bushings 4 PG9 glands with gasket, 3x4-9mm, 3x3-5mm multi-channel bushing
Electrical connection	1.5 [mm ²], max 1 conductor for 1 terminal
Pressure connection	Pressure hose connections. External housing stubs, diameter 6 [mm]
Output	Galvanically isolated differential interface protected against ESD mcr BUS driver
Sensor range	Pressures from -500 to +500 [Pa]
Permissible positive pressure	100 kPa
Measurement error	+/-1.5 [%]

5.5. mcr PSR / mcr PSRC manual control panel



An elevated manual control panel is used to control the system from a distance using a key switch. It allows the lead firefighter to manually activate or deactivate the pressurization smoke control system. The panel should be placed near emergency exits in areas easily accessible for emergency responders. The panel signals control panel operation and provides information about the following states:

- power supply - a green indicator light indicates "OK" control panel status,
- failure - a yellow indicator light reports system failure,
- alarm - a red indicator lamp reports an alarm operating state,
- blocked - a blinking yellow indicator lamp reports manual blocking.

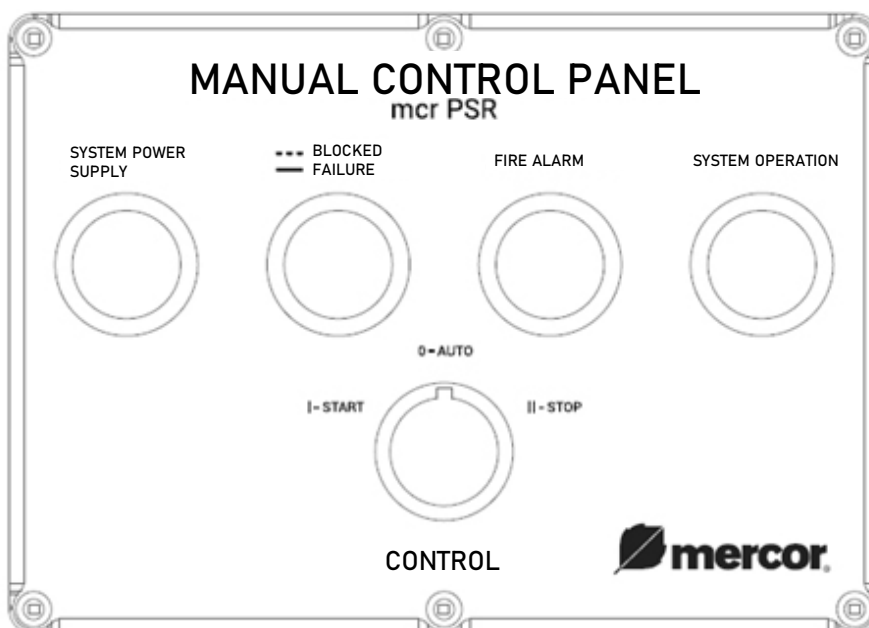
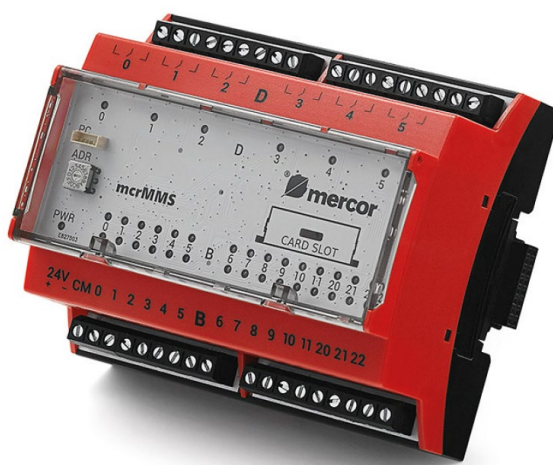

Figure 24 PSR/PSRC manual control panel - overview.

PSR/PSRC technical parameters	
Connecting to the mcr OMEGA panel	Hard-wired, multicore cable (PSR) or digital (PSRC)
Housing ingress protection:	IP 44
Control method:	Cam switch with key, 3 positions (0-AUTO, I - TEST, II - STOP)
Signaling method:	Indicator light, 3 colors depending on the presented information
Housing material:	ABS
Dimensions	206 mm x 126 mm x 78 mm

When using mcr PSRC, it is required to insert a communication card into the mcr MMS module (CARD SLOT).



5.6. mcr WPS elevated control panel

The EXi-F elevated control panel is used to control the system from a distance. By using an integrated HMI panel, the device allows a detailed preview of the status of all ICR pro panels and regulators connected to the system, audiovisual signaling of alarms and damage to the individual EXi-F system components. Moreover, it allows manual activation or deactivation of the pressurization smoke control system using buttons on the device housing.

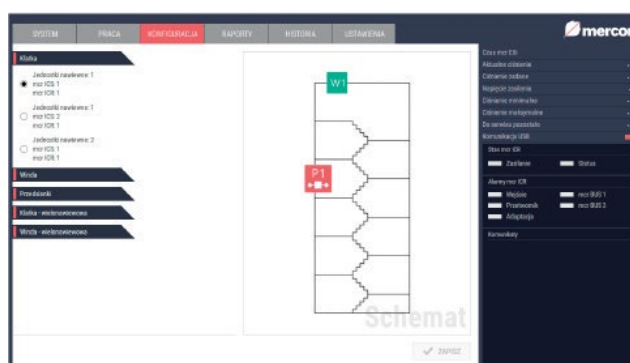

Figure 25 Elevated control panel with visualization.

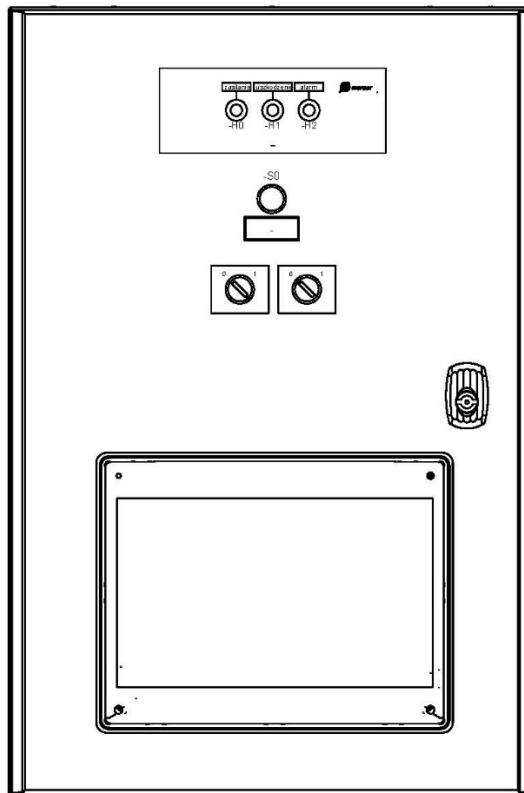

Figure 26 Overview of an elevated control panel with visualization.

Elevated technical panel with visualization technical parameters	
Power supply	230[V], AC +10%. -15%, 50Hz
Protection	Internal overcurrent circuit breakers
Basic dimensions	600 mm x 400 mm x 200 mm
Housing material	Powder-coated steel
Housing ingress protection	IP30
Mode of communication	mcr BUS communication network
FSS alarm transmission method	Hard-wired
Data presentation	Visualization on the HMI panel

5.7. Duct smoke detector

Where the air inlet is not at the roof level, in an inlet duct or directly adjacent to air supply ducts, a smoke detector should be installed to trigger automatic deactivation of the pressure difference system if considerable amounts of smoke are present in the supplied air. When air inlets are located at the roof level, two air inlets (two intake vent system) should be used. Each inlet should be secured by means of an independently operated system of dampers, with a duct smoke detector installed upstream from each damper.

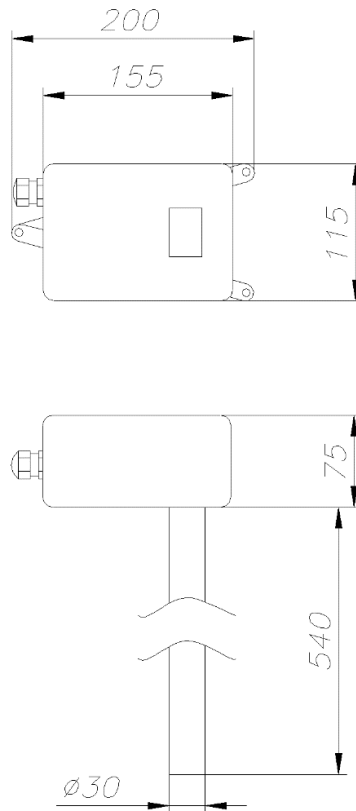

Figure 27 SDD-65-RAC duct smoke detector - overview.

5.8. Intake vent switching system

When air inlets are located at the roof level, two air inlets (two intake vent system) should be used, placed at a distance and facing different directions, so that they cannot be located directly leeward of the same source of smoke. Each inlet should be able to independently provide the full air supply required by the system. Each inlet should be protected by an independently operated system of dampers to control smoke spread, where if one damper closes due to the air being contaminated with smoke, the other inlet will provide uninterrupted supply of air required by the system. Air contaminated with smoke will be detected by smoke detectors placed upstream of each damper.

The above tasks will be executed by an intake vent switching system based on two dampers with B(L)E Belimo actuators operating in opposite directions.

Recommended damper dimensions for a two intake vent system

No.	System type	Damper			
		a	b	c	scale
		[mm]	[mm]	[mm]	[kg]
1	mcr EXi-F 100	1100	1114	115	18.5
2	mcr EXi-F 90	1100	1114	115	18.5
3	mcr EXi-F 80	900	914	115	14
4	mcr EXi-F 71	900	914	115	10
5	mcr EXi-F 63	700	714	115	10

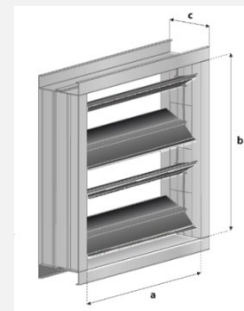

* P30 frame

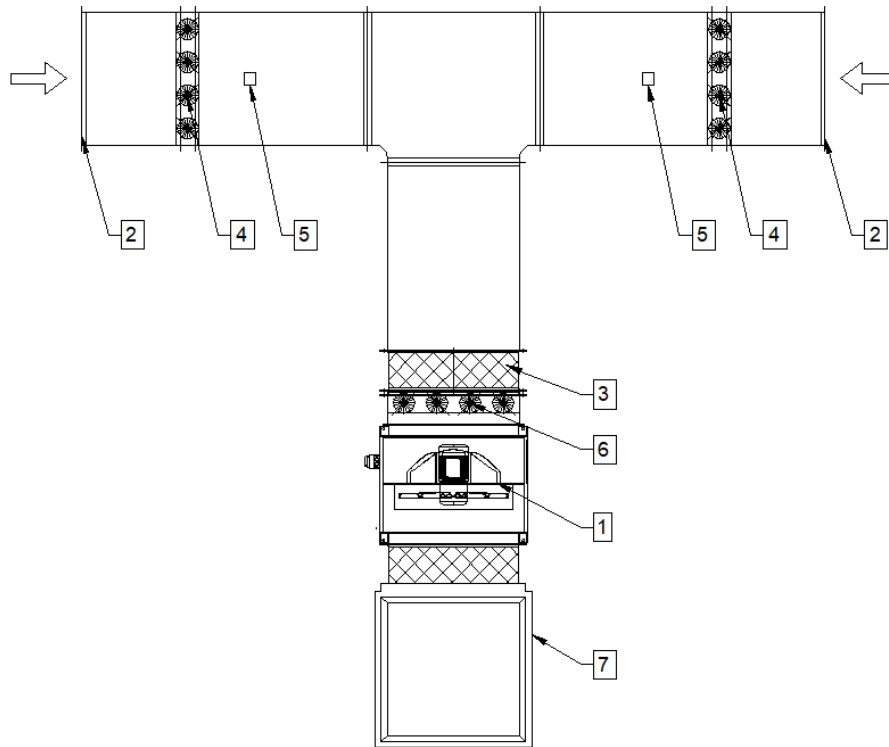

Figure 28 Sample installation of an air supply kit for the mcr EXi-F system in the roof-mounted version with two air intake vents: 1 - fan, 2 - intake vent, 3 - flexible connection, 4 - dampers with actuators in a double intake vent system, 5 - duct smoke detector, 6 - shut-off damper, 7 - ventilation duct.

5.9. mcr ICP lobby controller



mcr ICP regulators are used where positive pressure control is required, for example in smoke-control lobbies. This maintains the target positive pressure in the protected space or the required air flow velocity through the open door opening, separating the space with increased pressure from the space without increased pressure by changing the opening rate of the control damper.

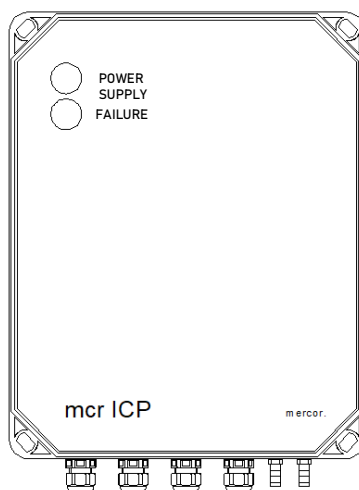

Figure 29 mcr ICP regulator overview (dimensions - Without glands and controls: 340 mm x 270 mm x 106 mm, with glands and indicator lights: 367 mm x 270 mm x 120 mm).

Basic technical parameters of the mcr ICP positive pressure regulator	
Power supply	24 VDC ±15%
Operating temperature	-20÷60 °C
Housing ingress protection	IP56
Maximum current consumption	250 mA
Pressure measurement range	-500 to +500 Pa
Temperature measurement range	-40÷85 °C
Number of mcr BUS communication lines	1
Number of voltage-free outputs	1
Number of voltage-free inputs	2

The mcr ICP regulator controls four damper actuators to maintain a constant pressure difference in the protected space and ensure compensation for the smoke exhaust fan.

Parameter programming is done through the on-site configuration application.

The regulator may operate as an independent device or as part of the system, together with the mcr ICR pro regulator. If the controllers are connected into a network, the user obtains the capacity for centralized reading of parameters from all the connected controllers through the mcr ICR pro regulator and to set different rpm values for the fan supplying air to the lobbies for each controller. In the case of independent work, the device status may be read through the relay output signaling failure.

The device offers two input pairs that receive silicone pneumatic hoses leading to zones where the pressure difference is to be measured. The first two connections on the right are for zone 1 (P1 upper input, P2 lower input), while the other two connections are for zone 2 (P3 upper input, P4 lower input).

- P1 - zone 1 input, by default connected to the pressure value for the object where positive pressure is to be created,
- P2 - reference pressure input,
- P3 - zone 2 input, by default connected to the pressure value for the object where positive pressure is to be created,
- P4 - reference pressure input.

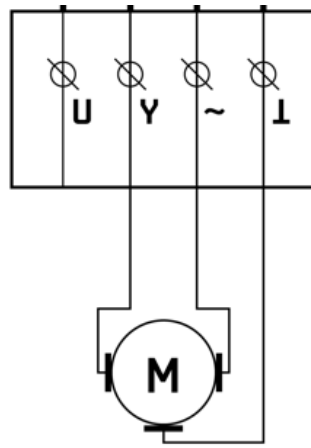

Figure 30 Connections circuit diagram for the Belimo NMQ/LMQ/SMQ series actuator.

An example connection diagram is presented in Figure 31. Actuators are connected to the regulator only through a dedicated connection box. The box is equipped with a thermal fuse. The total length of cables between the regulator and the actuator must not exceed 15 m.

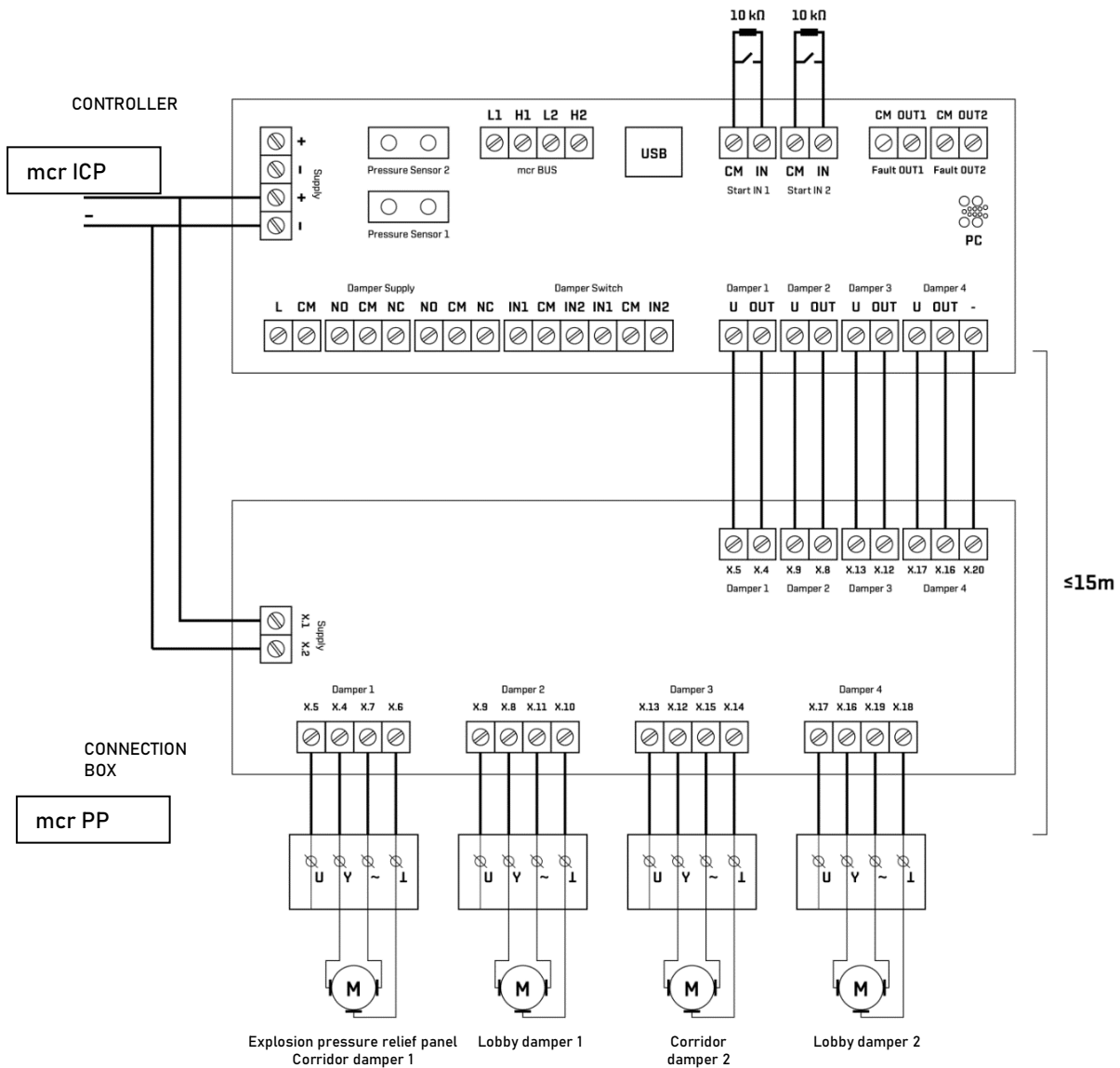

Figure 31 Connection of actuators to the mcr ICP regulator through the mcr PP connection box.

CAUTION:

A regulator that has not yet been configured is working as an explosion pressure relief panel and is (factory) configured to maintain 50 Pa. Only after the mcr ICR has been assigned an address in the controller configuration application. Changes may only be introduced into the controller configuration from the configuration application once the controller is physically connected to a computer. It is only possible to view the status of the controller from the mcr ICR configuration application. If the default setting is not appropriate, modify the controller configuration. The first step is to select the proper operating mode and to assign an address to the controller in case of network operation. Then, for modes II, III and IV, calibration must be performed. Failure to perform calibration is indicated by a red indicator light on the device and in the app. Without calibration, the device will not respond to signals from the FSS system.

Configuration and adjustment of the regulator is performed by authorized "MERCOR" S.A. service.

5.10. mcr PP connection box

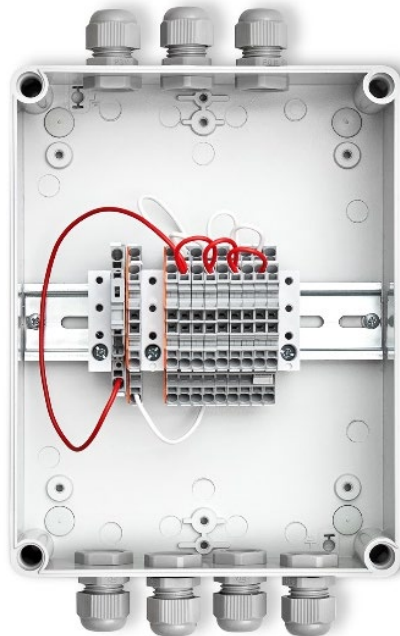

Connecting actuators to the controller can be done through a dedicated connection box. The box is equipped with a thermal fuse. The total length of cables between the controller and the actuator must not exceed 15 m. External box dimensions: 220x170x86mm.

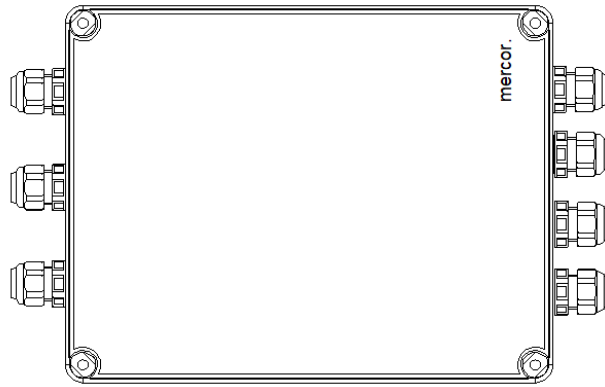

Figure 32 Overview of the mcr PP connection box (dimensions: without glands: 220 mm x 170 mm x 86 mm, with glands: 274 mm x 170 mm x 86 mm).

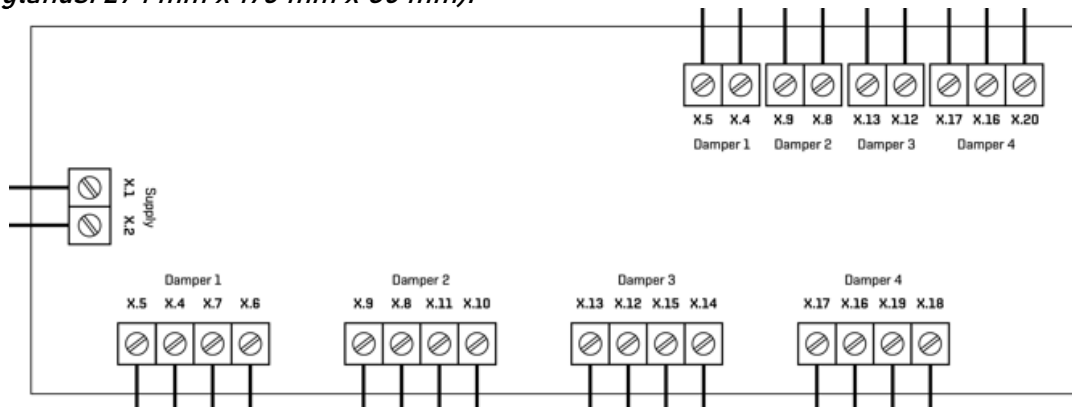

Figure 33 Terminals in the mcr PP box.

5.11. Damper for lobby systems

mcr EXi-F system air supply units may be equipped with multi-blade control dampers (mcr EPSCR-A, mcr EPSCR-B) with LMQ/NMQ/SMQ24A-SR actuators. The damper rotating mechanism consists of bearings and cogs hidden inside the profile housing or provided in the form of steel tendons. Dampers are available in sizes from 200 x 200 mm to 1500 x 1500.

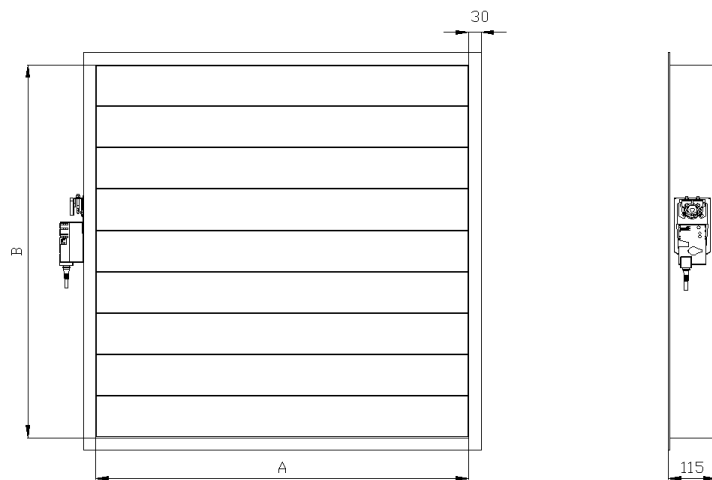

Figure 34 Overview of the EPSRC-A damper.

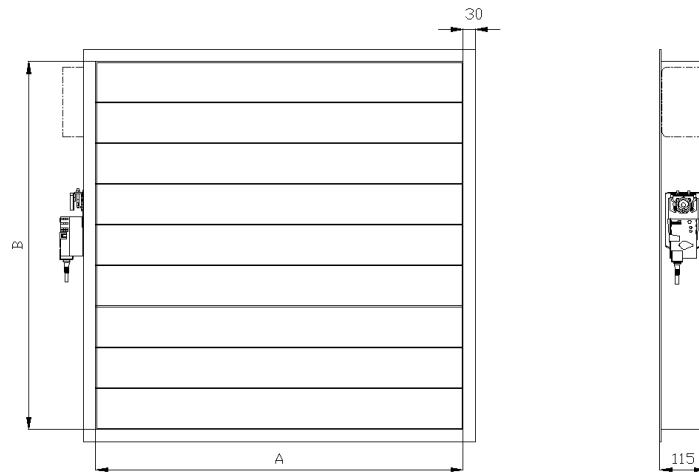

Figure 35 Overview of the EPSRC-B 9 damper (with additional connection box).

5.12. mcr HT anti-icing system

The mcr HT kit is used to protect mcr EXi-F air supply units from blockage due to icing. The system uses 500 W directional infrared radiators, with additional radiators available if needed. The system is controlled by a thermostat. This guarantees automatic device operation.

Once attached, the system consists of an infrared radiator with wires connected to the connection box. Power supply connection with protection is located inside the mcr HTPP connection box installed in the fan housing. 230 V power is supplied via a wire from the mcr Omega control panel. Voltage activation during an alarm.

Periodical inspections may check whether no foreign objects such as leaves or other flammable items are deposited on the radiator. Access to the radiator is possible through a service opening of the air supply unit.

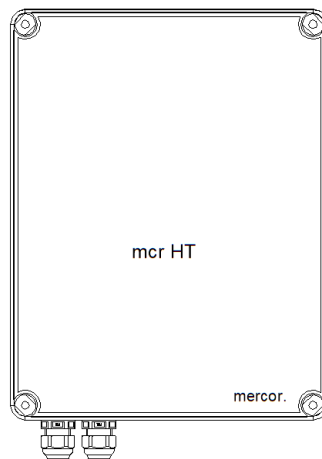
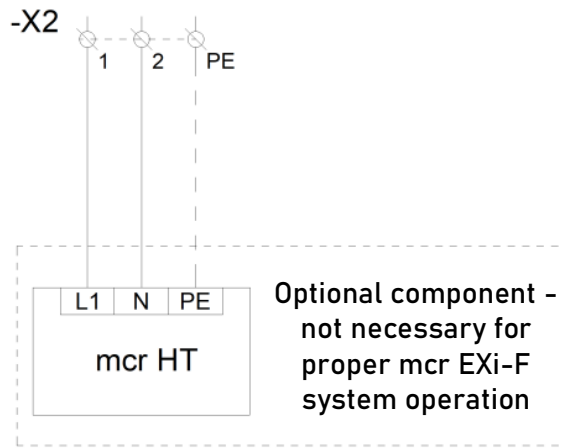

Figure 36 Overview of the mcr HTPP connection box (dimensions: Without glands: 220 mm x 170 mm x 86 mm, with glands: 247 mm x 170 mm x 86 m).



WZ - power cable provided by the customer
 PP - connection box on the fan facade
 W1, W2, W3 - OLFLEX HEAT 180 SiHF 3G2.5 cables
 X1:D - lower tracks of the X1 terminal strip
 X1:G - upper tracks of the terminal strip X1
 G1, G2 - radiators*
 *Only install the G1 radiator for the mer HT 500 W version; for the mcrHT 1000 W, install both radiators

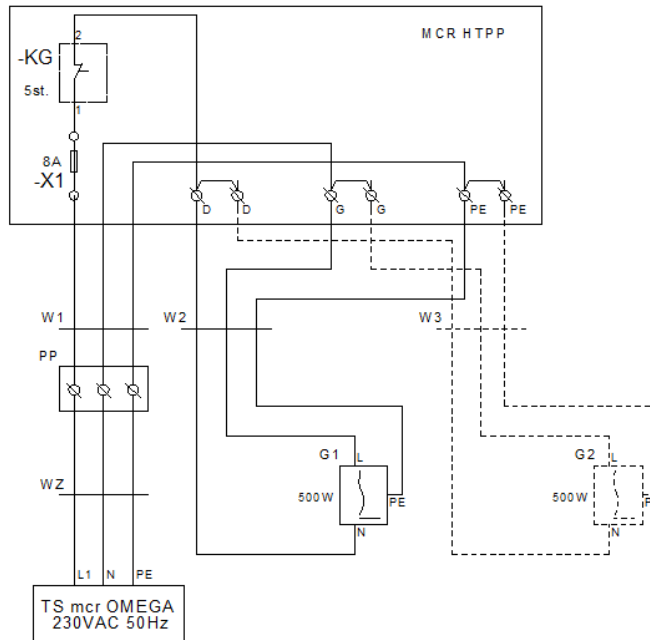

Figure 37 Internal HT system connections circuit diagram.

mcr HTPP connection box specification	
Power supply	230 V AC
Protection	Thermal fuse, fast 8 [A]
Operating temperature	-25÷55 [°C]
Housing ingress protection	IP44
Dimensions	220 mm x 170 mm x 86 mm
Installation	To a flat surface, using 2 screws
Cable bushings	Bushings 3 PG13.5 glands with gasket
Electrical connection	Maximum conductor diameter 2.5 [mm ²]

5.13. mcr SEP network separators

In the case of large-area facilities, where the distance between the subsequent elements of the communication loop is more than 250 m, mcr SEP network separators are used to prevent network signal fading. Two separator variants have been developed for network requirements:

- mcr SEP1 - variant for the mcr BUS network
- mcr SEP2 - variant for the RS485 network

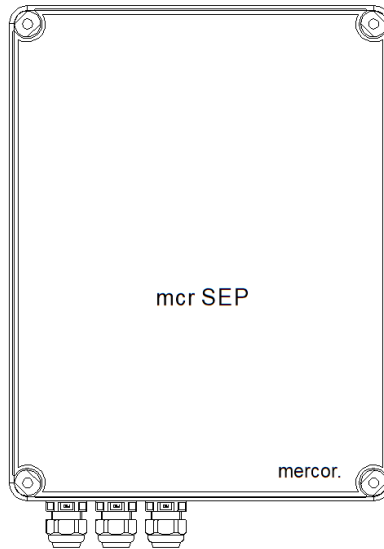

Figure 38 Overview of mcr SEP network separator (dimensions: without glands: 220 mm x 170 mm x 86 mm, with glands: 247 mm x 170 mm x 86 mm).

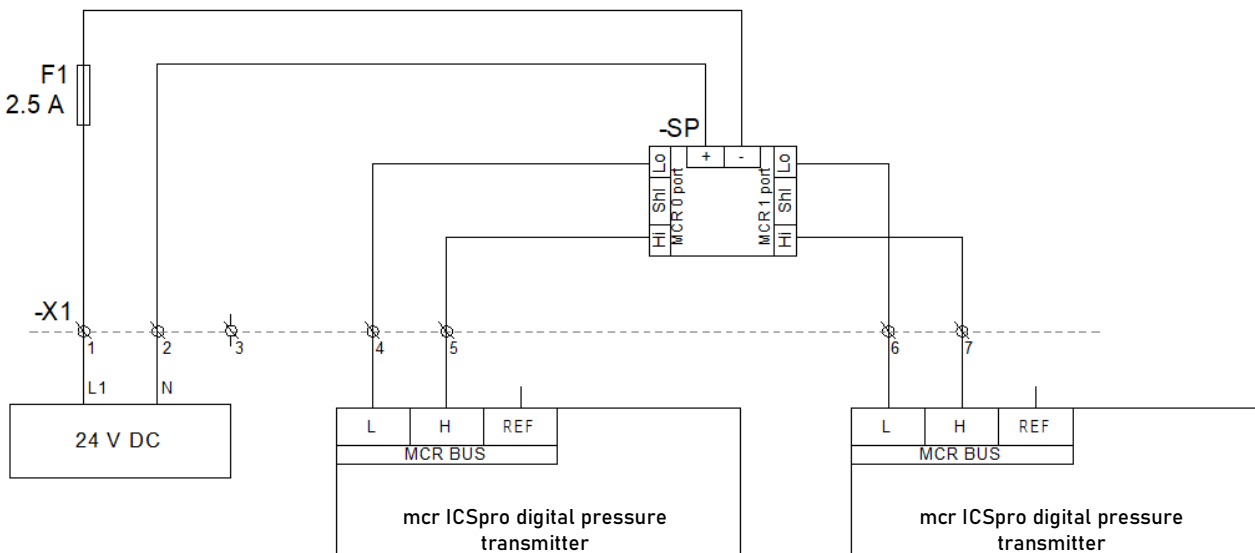

Figure 39 mcr SEP connections block diagram.

mcr SEP basic technical parameters	
Power supply	24 VDC ±15%
Maximum current consumption	250 mA
Housing ingress protection	IP54
Housing Material	PC, PS, ABS

5.14. Temperature transmitter

Pressure transmitters in the mcr EXi-F system are used to determine the flow direction of air in reversing systems. "MERCOR" S.A. offers 2 types of transmitters: MB series and AR series.

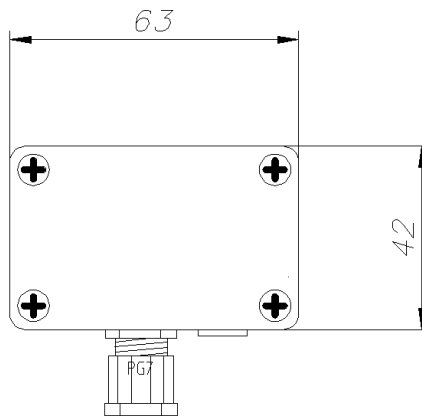

Figure 40 Overview and connection details for the MB series temperature transmitter.

terminals	description
1	power input +9...30 V dc
2	0 V dc power input
3	A RS485
4	B RS485

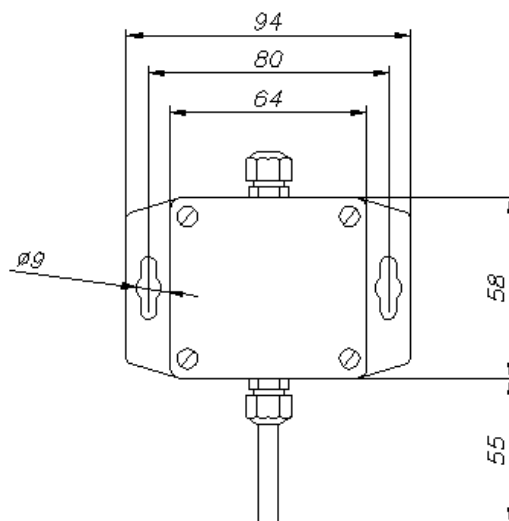

Figure 41 Overview for the AR series temperature transmitter.

terminals	description	
1-2	power input 9...36 V dc; 9...28 V ac	
3	+RS	rS485 interface lines
4	- RS	
JP1	jumper terminating the RS485 interface line with a 120 Ω resistor (termination enabled when JP1 is shorted)	

5.15. Magnetic sensors (reeds)

Magnetic sensors can be used in mcr Omega panels to control the position of doors and windows. These devices consist of two parts: a magnetic sensor and a magnet. When doors and windows are closed, the magnet and sensor are in frontal contact. Opening a window/door causes the magnet to move away from the magnetic sensor, switching the sensor contacts.

Sensors are available in two connection variants:

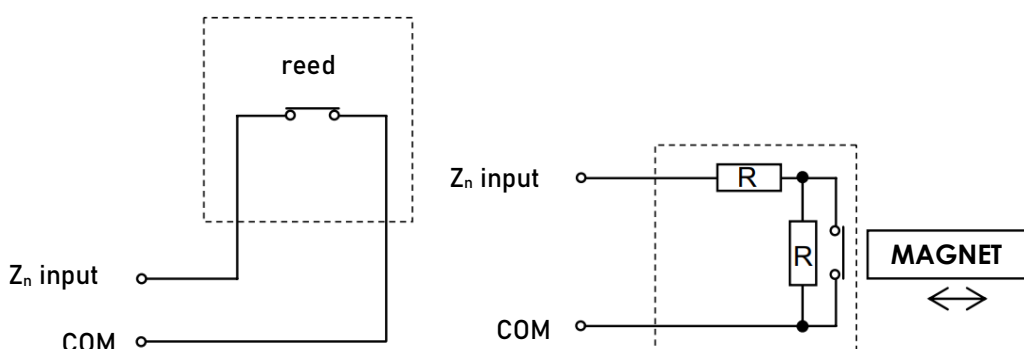

Figure 42 Manners of connecting magnetic sensors (reeds).

Without line continuity check - only the normally closed contact of the sensor is used
 With line continuity check - a pair of parametric resistors allow to distinguish between a circuit break and correct opening of the sensor-magnet connection

Magnetic sensors technical parameters	
Type of detector	NC / 2EOL/NC
Parametric resistors	2x1,1kΩ
Maximum reed switchable voltage	20 V
Maximum switchable current	20 mA
Transient resistance	150 mΩ
Environmental class	II
Maximum humidity	93±3%
Operating temperature range	-10°C ÷ 55°C

5.16. Differential pressure switch

This device is used to monitor the activation of an air supply unit, used in systems with a backup unit. When the basic unit fails to activate, mcr Omega switches the system, activating the backup unit. Pressure switches are equipped with screw connections and a contact output. The difference in pressure, positive or negative pressure, causes the diaphragm to deflect and shortens the contacts. The switching value is selected by means of the know, which increases or reduces the pressure exerted on the membrane. The switching cycle is executed with a fixed hysteresis. A pressure switch is installed directly

on the fan using mounting brackets and screws. The connection stubs are placed in the ventilation duct and connected with a flexible hose to the pressure switch according to the diagrams below. Stripped and terminated wires are inserted into the housing through the gland to the screw terminals (there is no need for using connectors).

The pressure switch should be installed on the fan housing and set to a maximum pressure value of 30 Pa.

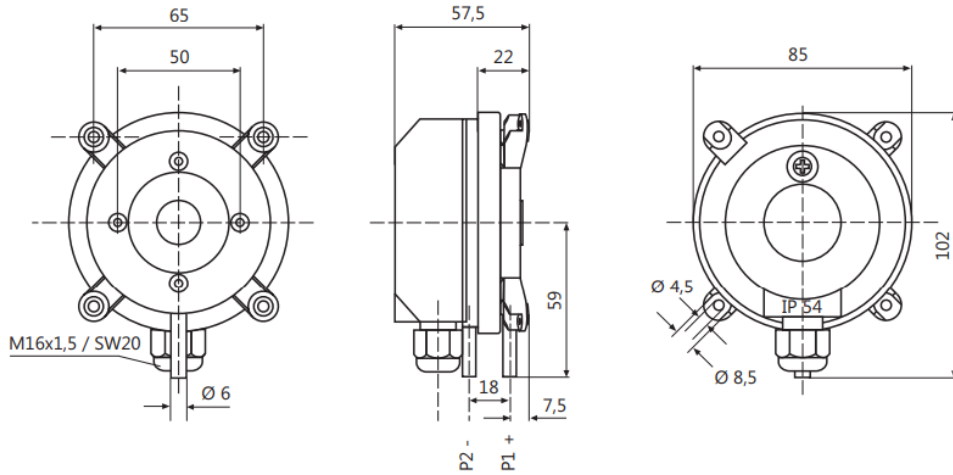

Figure 43 Differential pressure switch overview.

*Pressure input P1 (+) is connected downstream from the fan.
Pressure input P2 (-) is connected upstream from the fan.*

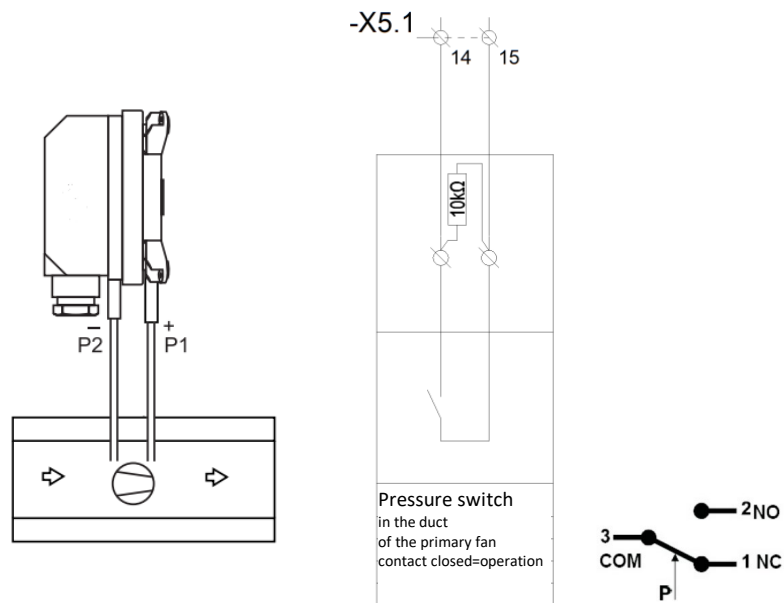

Figure 44 Electrical diagram of a LF or DW series differential pressure switch.

6. ELECTRICAL CONNECTION

mcr EXi-F system elements require the proper power supply that will guarantee delivery of a control signal or voltage to the device in case of fire. An electrical connection should be performed exactly as indicated by the attached diagram and in accordance with the guidelines presented under section 5 of this documentation. It should be performed by a person with confirmed electric qualifications, as per the

applicable regulations. Any inspection works concerning the system should only be performed after disconnecting the device from the power supply.

A sample electric connection diagram for a typical system is presented in the figure below.

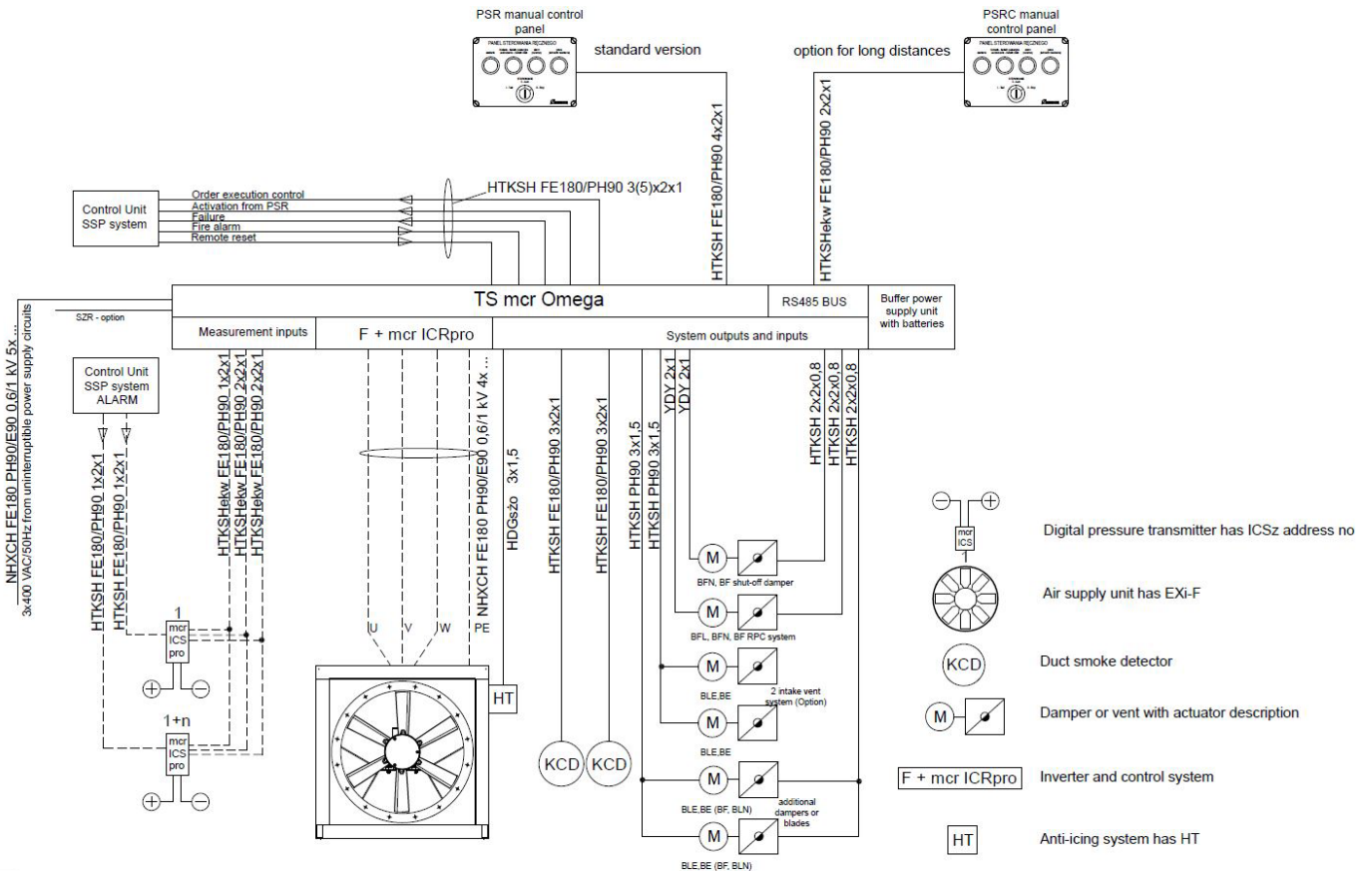

Figure 45 General electrical connection diagram for the EXi-F system: electrical connection, suggested types of wires for the mcr Omega control panel.

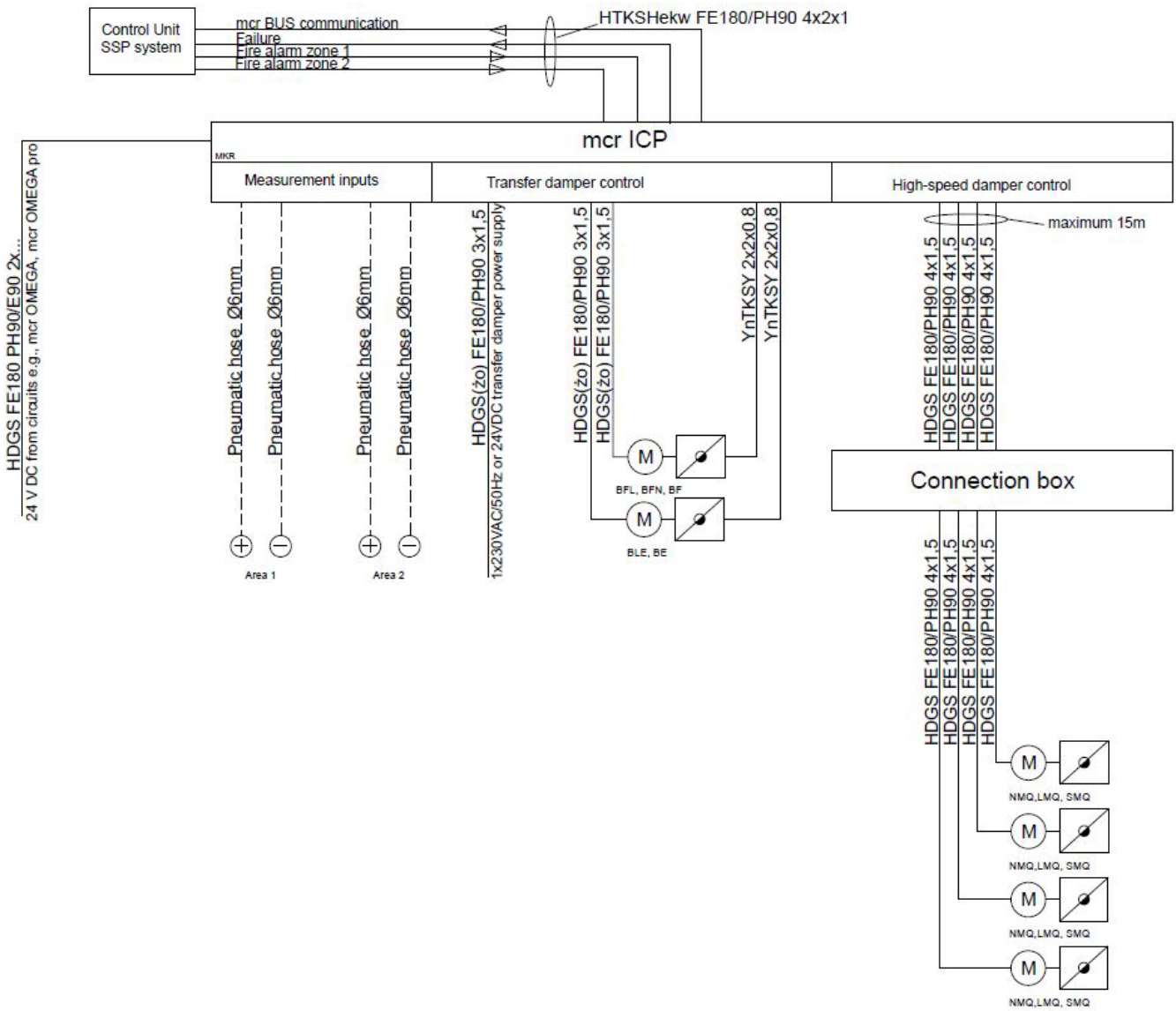

Figure 46 Electrical connection diagram for the mcr ICP lobby regulator handling 2 corridors and 4 high-speed dampers.

The lobby regulator handles between 2 and 4 dampers, as well as smoke control system vents installed on air supply ducts and may control smoke control system vents installed on a high-speed damper system.

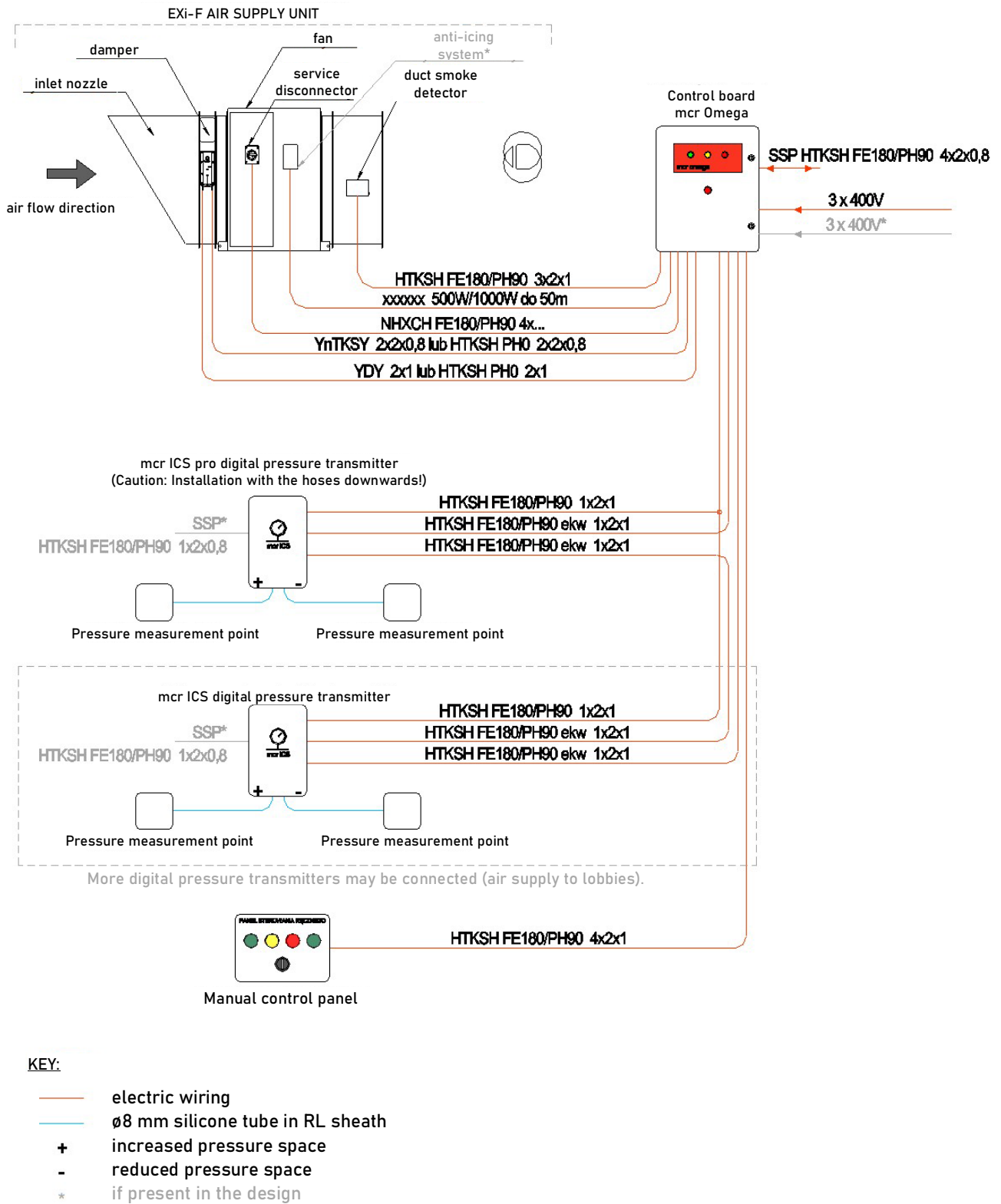

Figure 47 Wiring of the basic EXi-F unit.

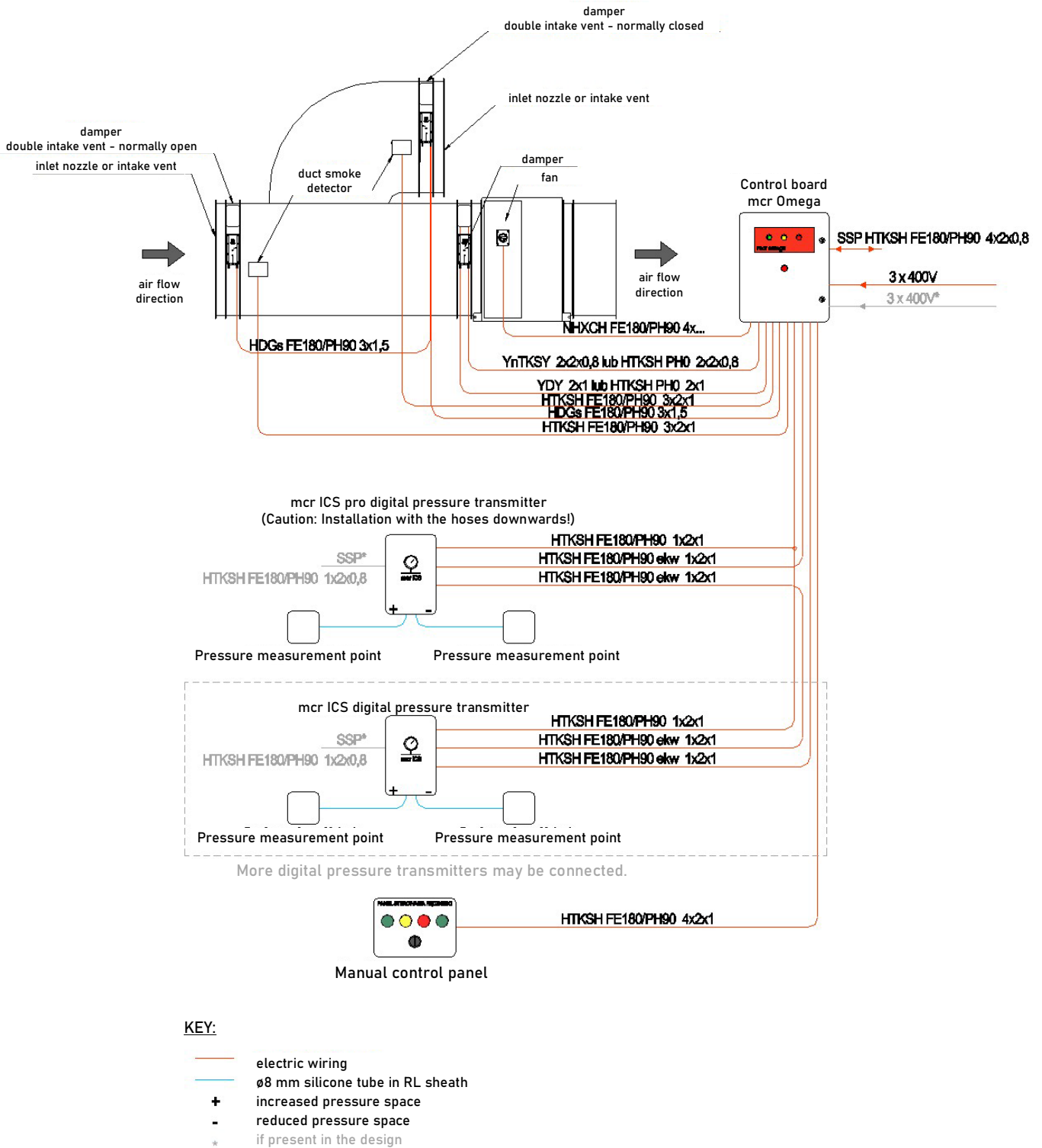

Figure 48 Wiring of the EXi-F unit with a two intake vent system.

SUGGESTED WIRING		
Designation on the diagram	Connections of automation components	Cable type
AK1	3x400 V uninterruptible power supply cable for the EXi-F FAN	NHXCH FE180/PH90 4x designed cross-section
AK2	3x400 V uninterruptible power supply cable for TS OMEGA	NHXH 5x designed cross-section
CP1	24 V DC power/control cable (dual air intake vent or smoke control vent)	HDGs FE180/PH90 3x1,5
CP2	24 V DC power cable (damper at the fan)	YDY 2x1 or HTKSH PH0 2x1
CP3	Monitoring cable	YnTKSY 2x2x1
CP4	Anti-icing power cable mer HT	HDGszo 3x1,5
CP5	mer LAM damper power cable	HDGs FE180PH90 2x1
DP1	Cable for KCD duct smoke detector	HTKSHekw FE180/PH90 3x2x1
DP2	Communication cable for mer ICS/ICP processing	HTKSHekw FE180/PH90 1x2x1
DP3	24 V DC uninterruptible power supply cable	HTKSH FE180/PH90 1x2x1
DP4	Cable for mer PSR manual control panel Cable for mer PSRc manual control panel	HTKSH FE180/PH90 4x2x1 HTKSHekw FE180/PH90 2x2x1
DP5	Control cable for actuators n=1,2 or 4	HTKSHekw FE180/PH90 (n+1)x2x1,5
PS	Cable supplied with the actuator 0.8 m from ICP	—
R1	Pressure transmitter to pressure transmitter mer ICS max. 5m	silicon tube fi 8 mm in sheath RL
EP1	Cables: SSP ALARM (NC) Operation confirmation (NO) Collective failure (NC) Reset (NO)	HTKSH FE180/PH90 4x2x0,8
EP2	Cables: Collective failure (NC) SSP ALARM (NC)	HTKSH FE180/PH90 2x2x0,8
EP3	Wire to ICS: SSP ALARM (NO)	HTKSH FE180/PH90 1x2x0,8

Key:



- Damper



-SRC high-speed damper



- Smoke control vent



- Static differential pressure measurement - Ø8 pulse lines



- Duct smoke detector



- Digital pressure regulator
Caution! Installation with pressure hoses downwards



- Digital pressure transmitter
Caution! Installation with pressure hoses downwards



- Pressure measurement point



- Connection box, n-number of fast actuators



- Actuator type (series)



- Manual control panel

U2 - Intake vent switching system

H.T.P.P - mcr HT anti-icing system

N.P - Lobby air supply system

N.K.S - Staircase air supply system

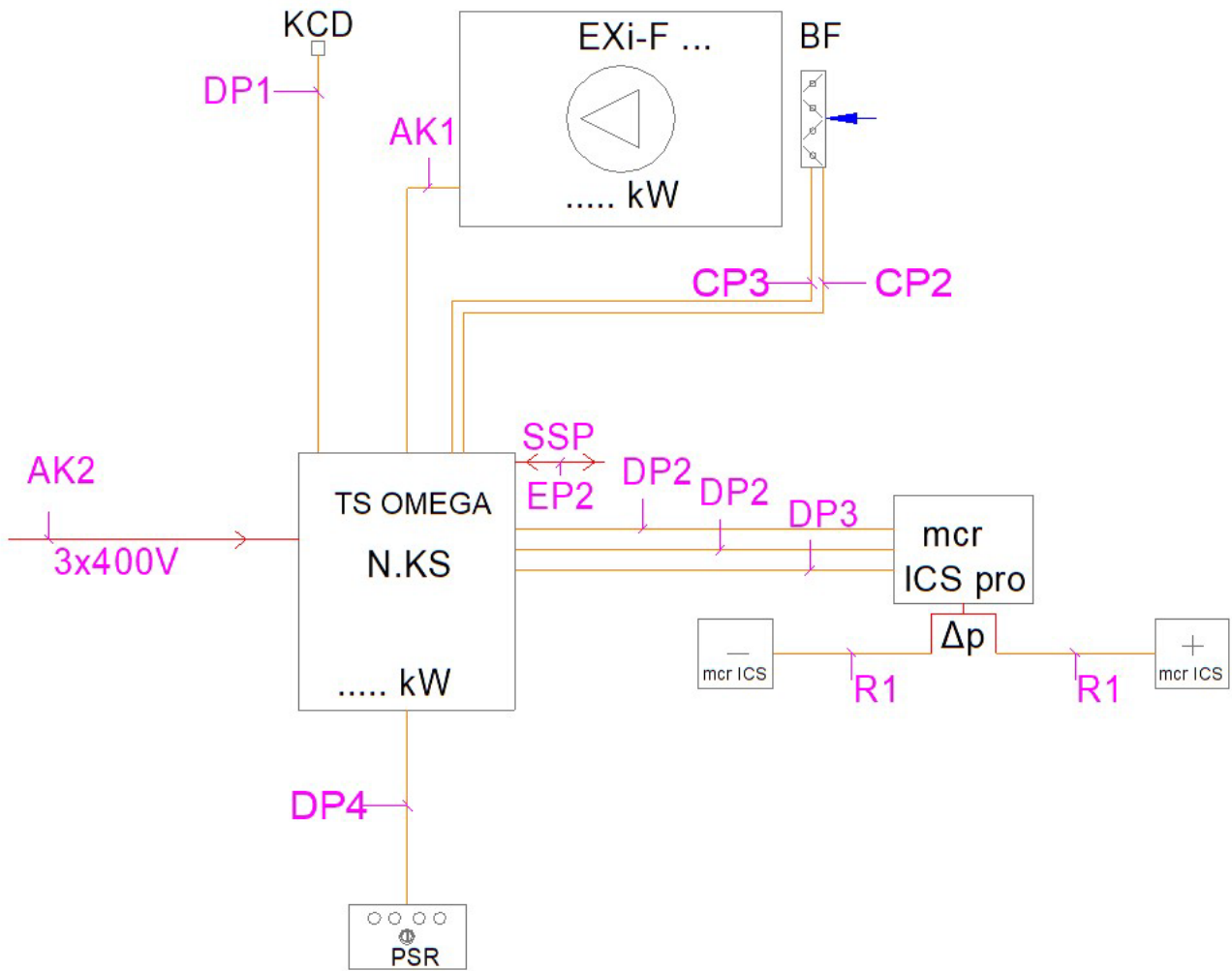

Figure 49 Schematic wiring diagram for a basic unit.

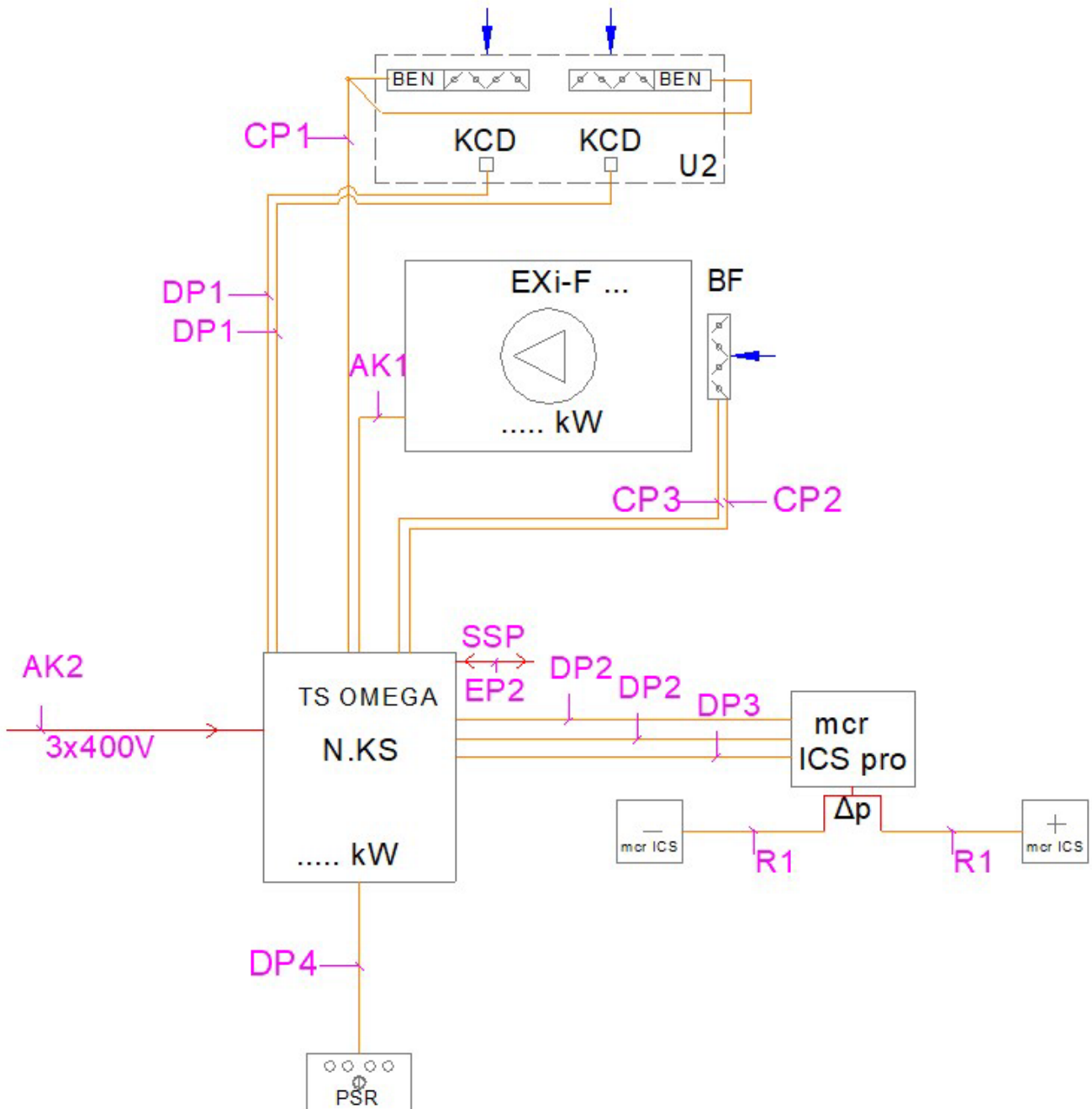

Figure 50 Schematic wiring diagram for a basic unit with a two intake vent system.

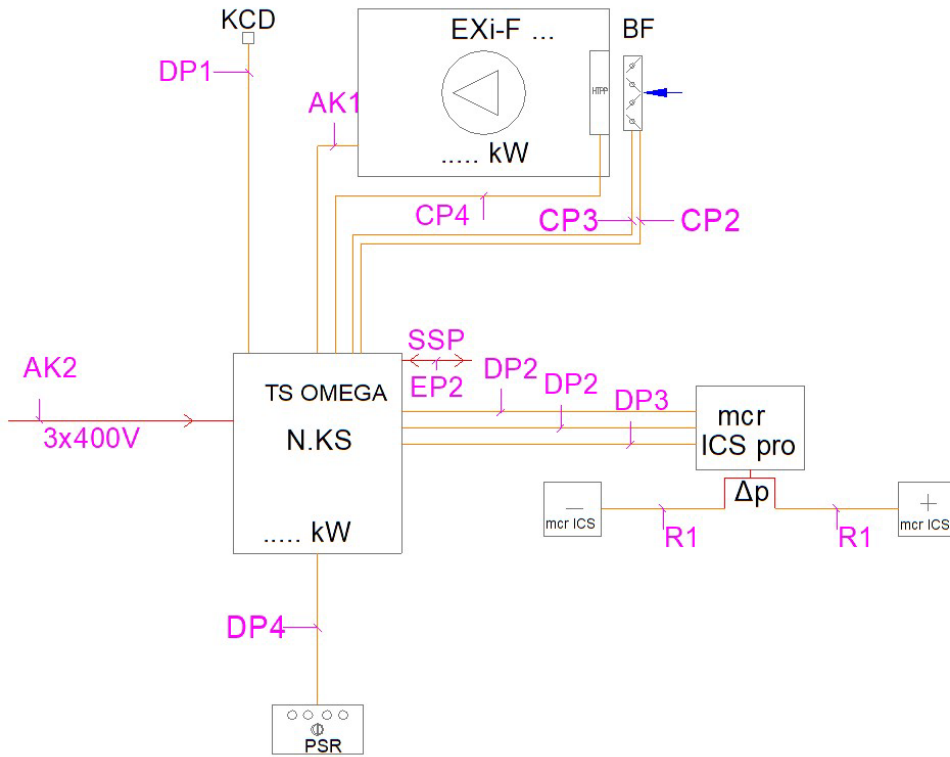

Figure 51 Schematic wiring diagram for a unit with the mcr HT anti-icing system.

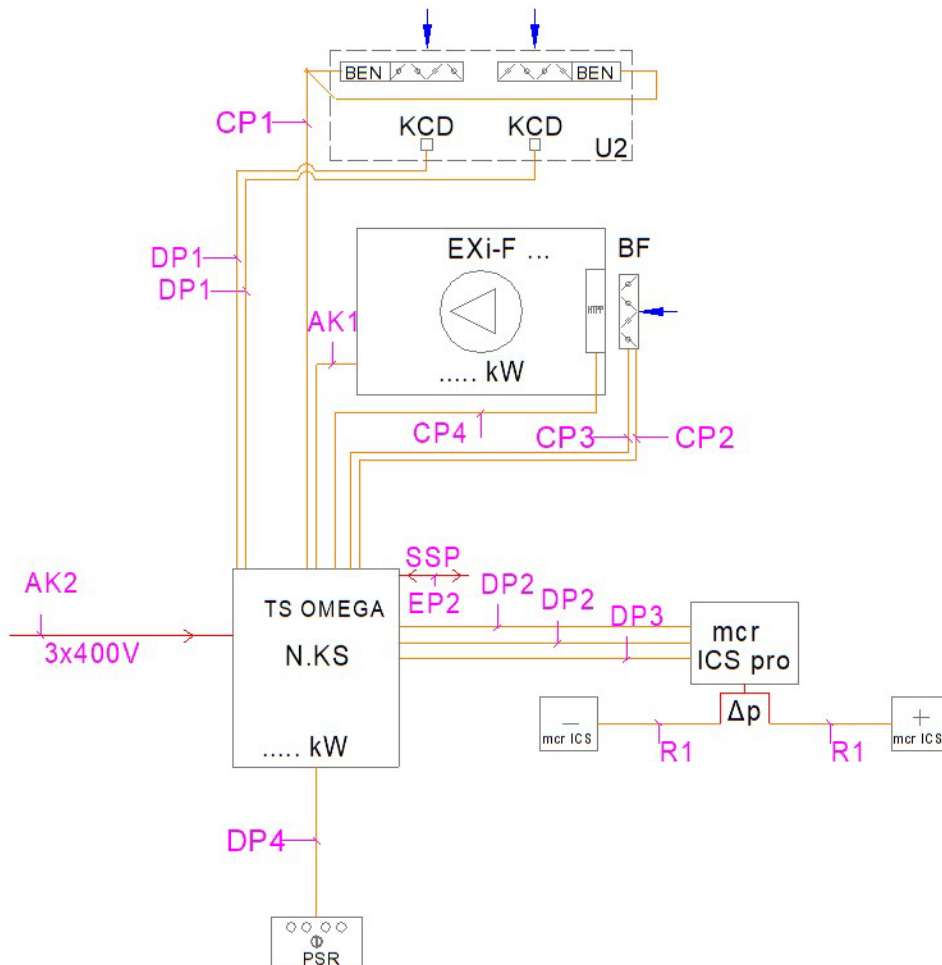

Figure 52 Schematic wiring diagram for a unit with a double intake vent system and mcr HT anti-icing system.

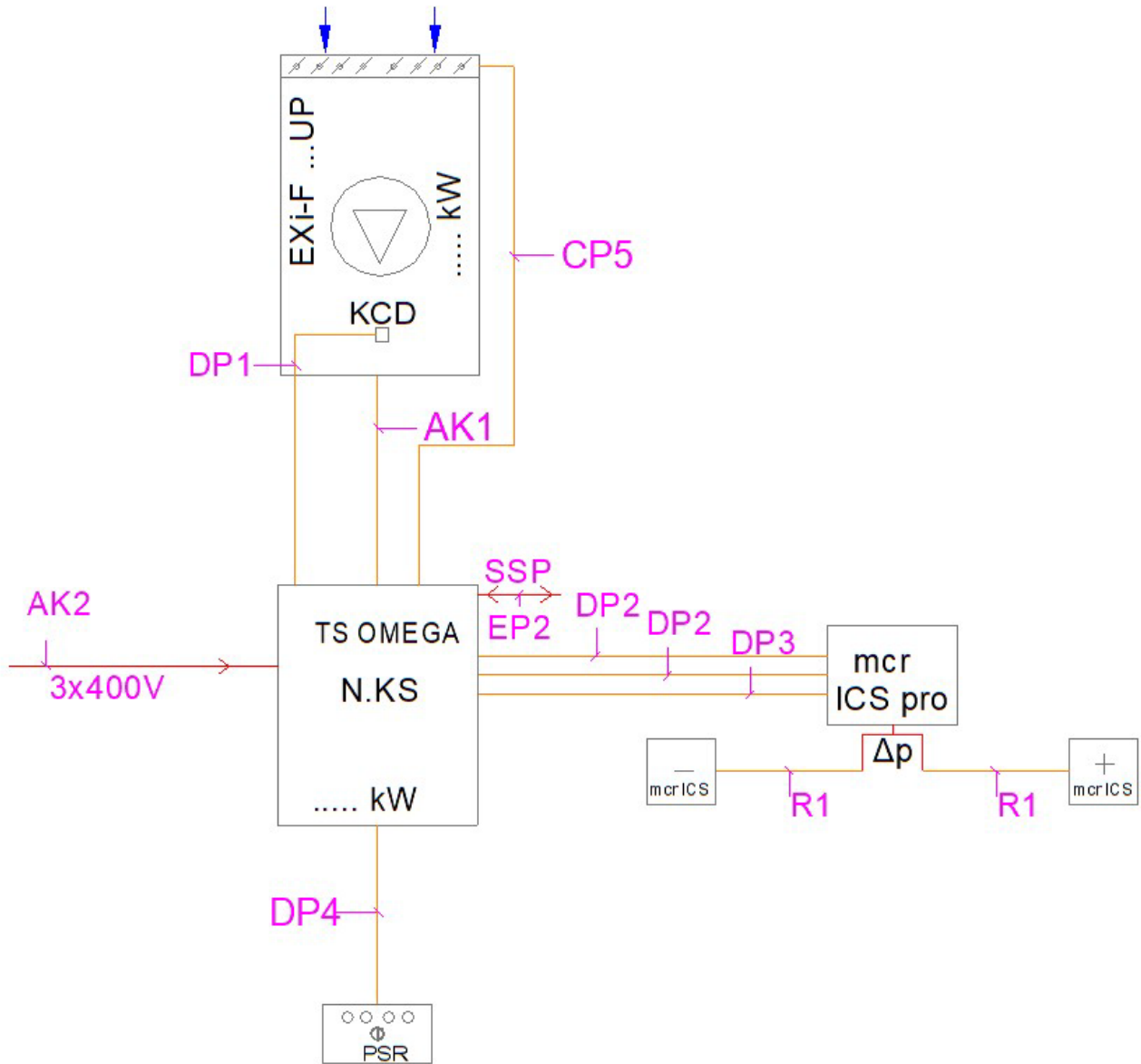

Figure 53 Schematic diagram of a vertical unit with a mcr LAM vent.

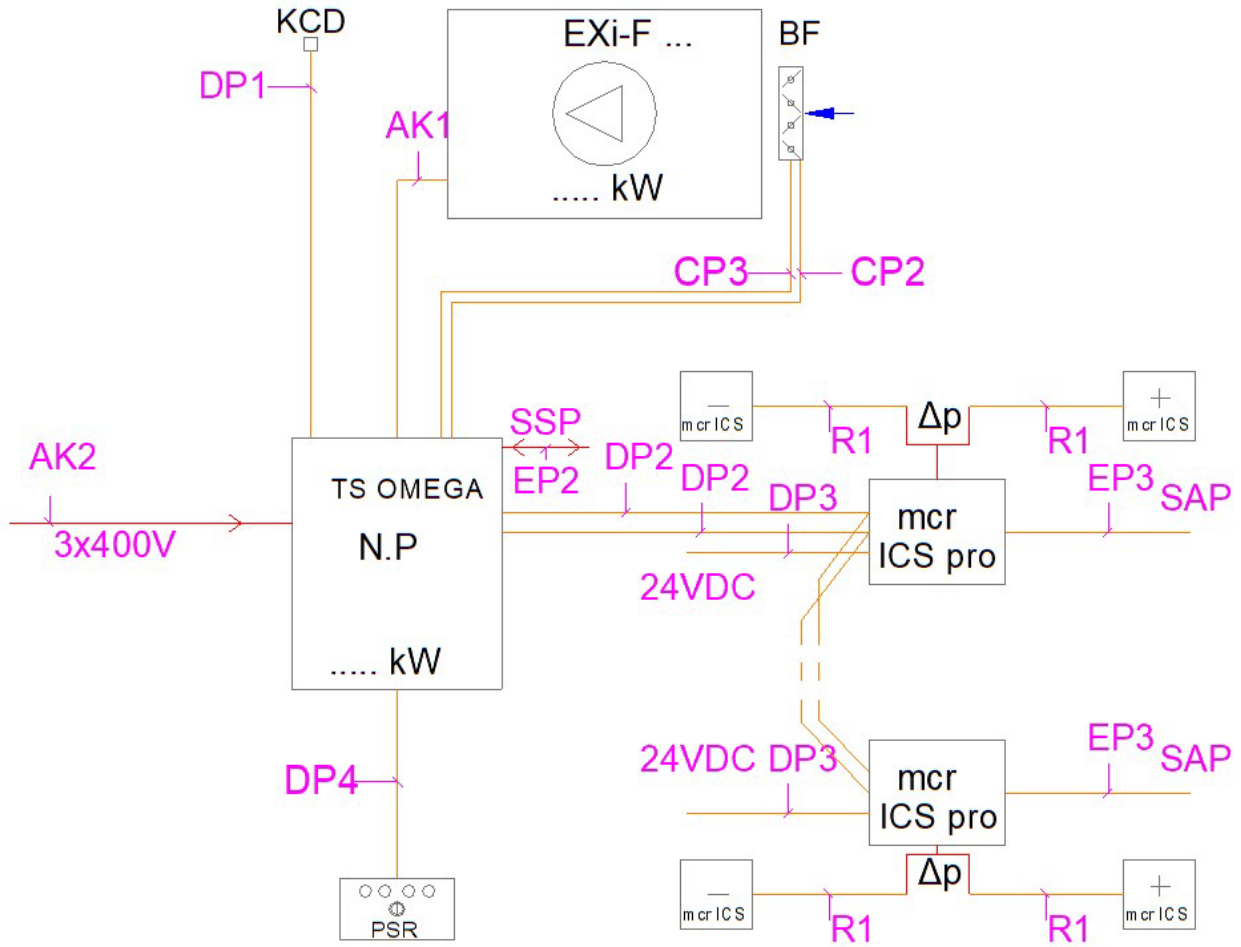

Figure 54 Schematic wiring diagram for lobby air supply.

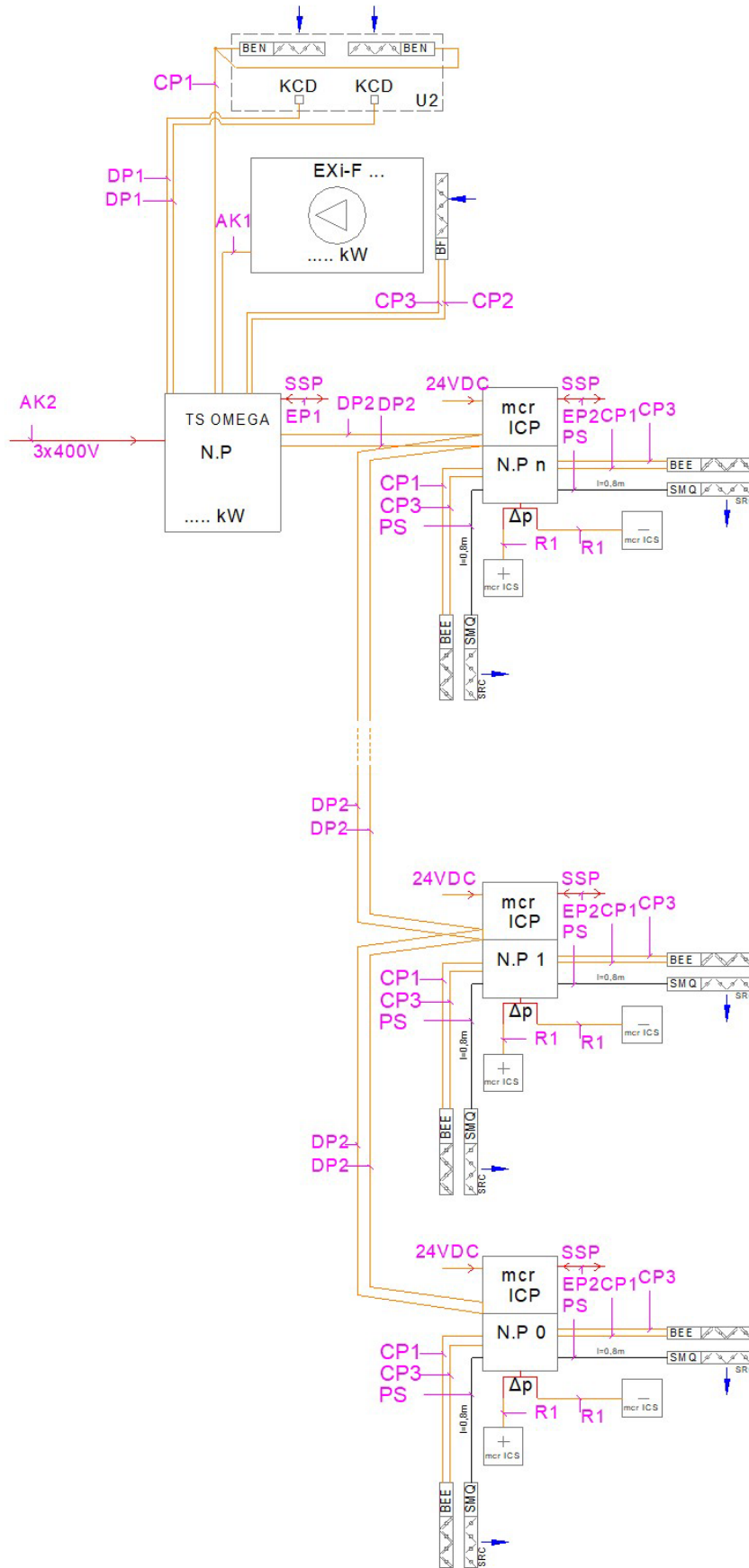

Figure 55 Schematic wiring diagram for a unit with high-speed mcr ICP dampers secured with smoke control system vents.

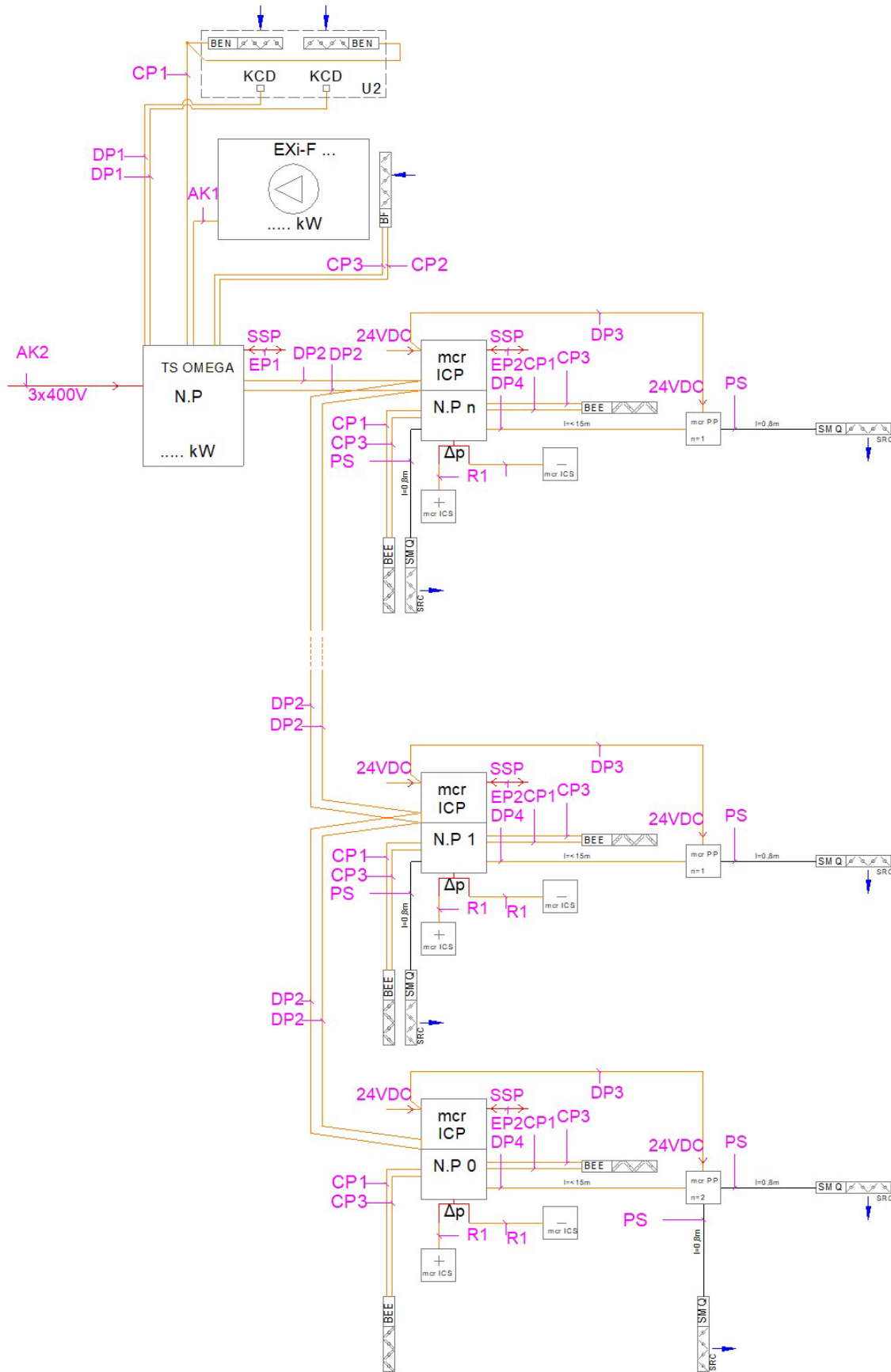

Figure 56 Schematic wiring diagram for a unit with high-speed mcr ICP dampers secured with smoke control system vents located at a higher distance from the regulator, using an mcr PP box.

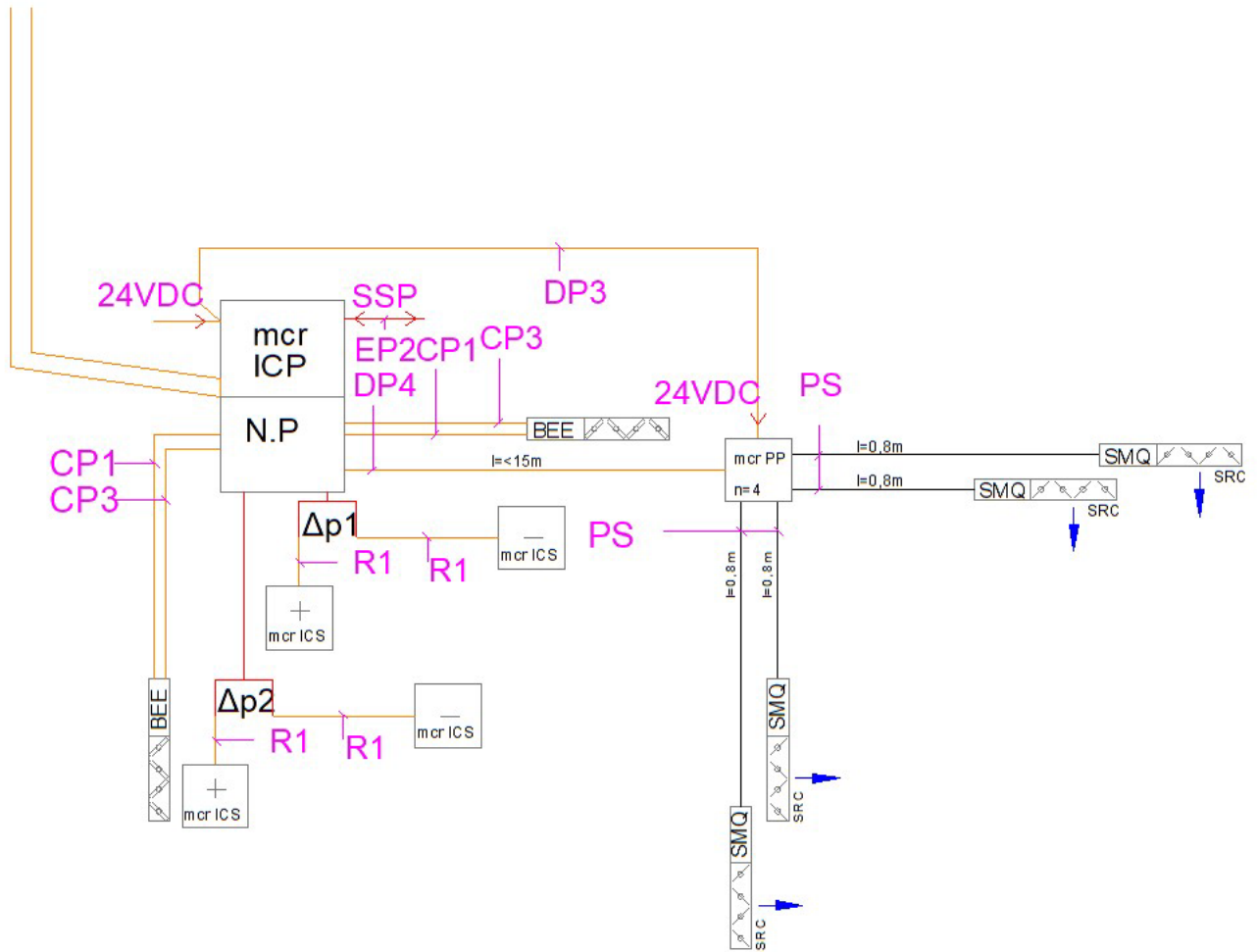

Figure 57 Schematic diagram for connecting four high-speed dampers to the mcr ICP high-speed damper regulator through a mcr PP box.

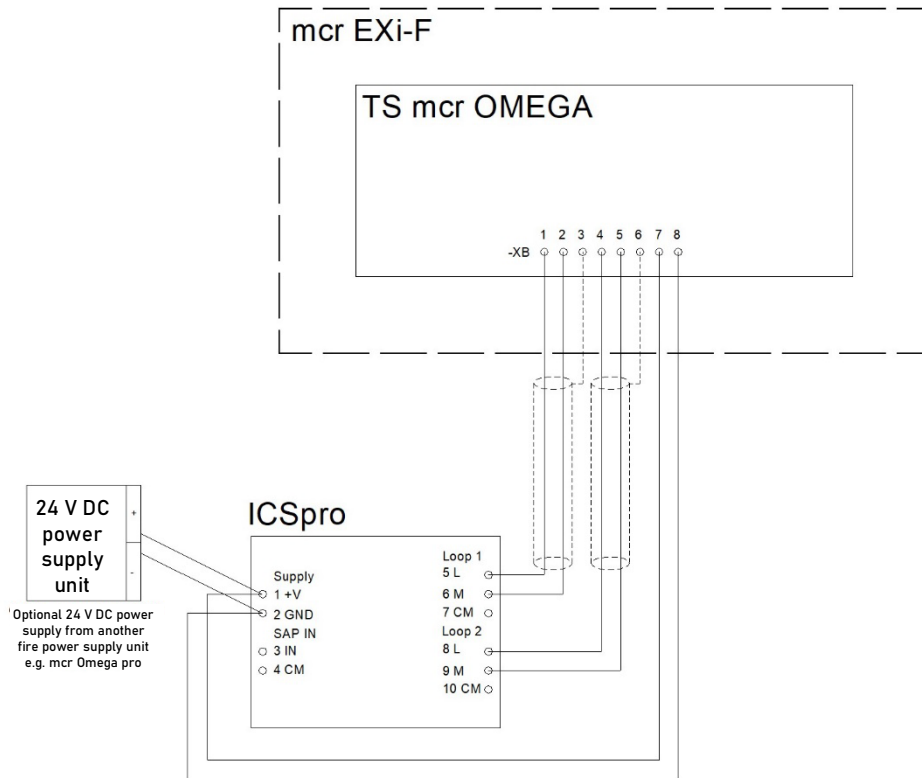

Figure 58 Block diagram for connecting a mcr ICS Pro pressure transmitter in a staircase-single transmitter setup.

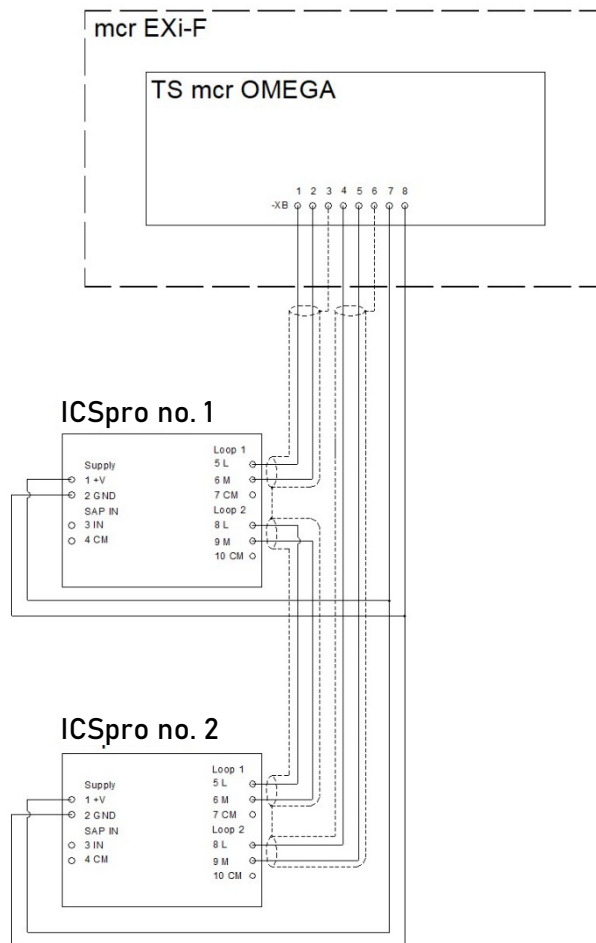
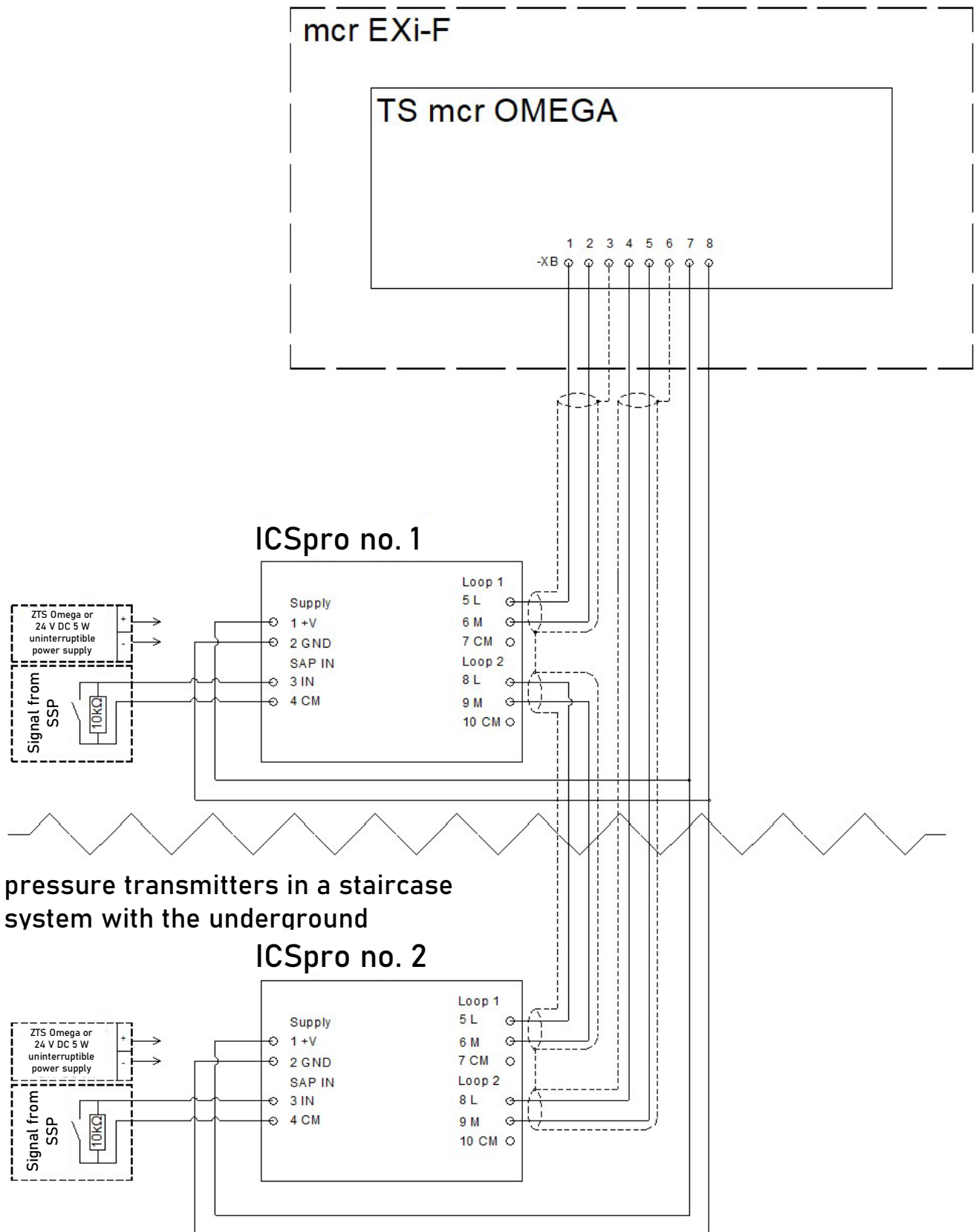

Figure 59 Block diagram for connecting mcr ICS Pro pressure transmitters in a staircase-two transmitters setup.



pressure transmitters in a staircase system with the underground

Figure 60 Block diagram for connecting mcr ICS Pro pressure transmitters in a staircase system with separate transmitters in the underground part triggered from the FSS.

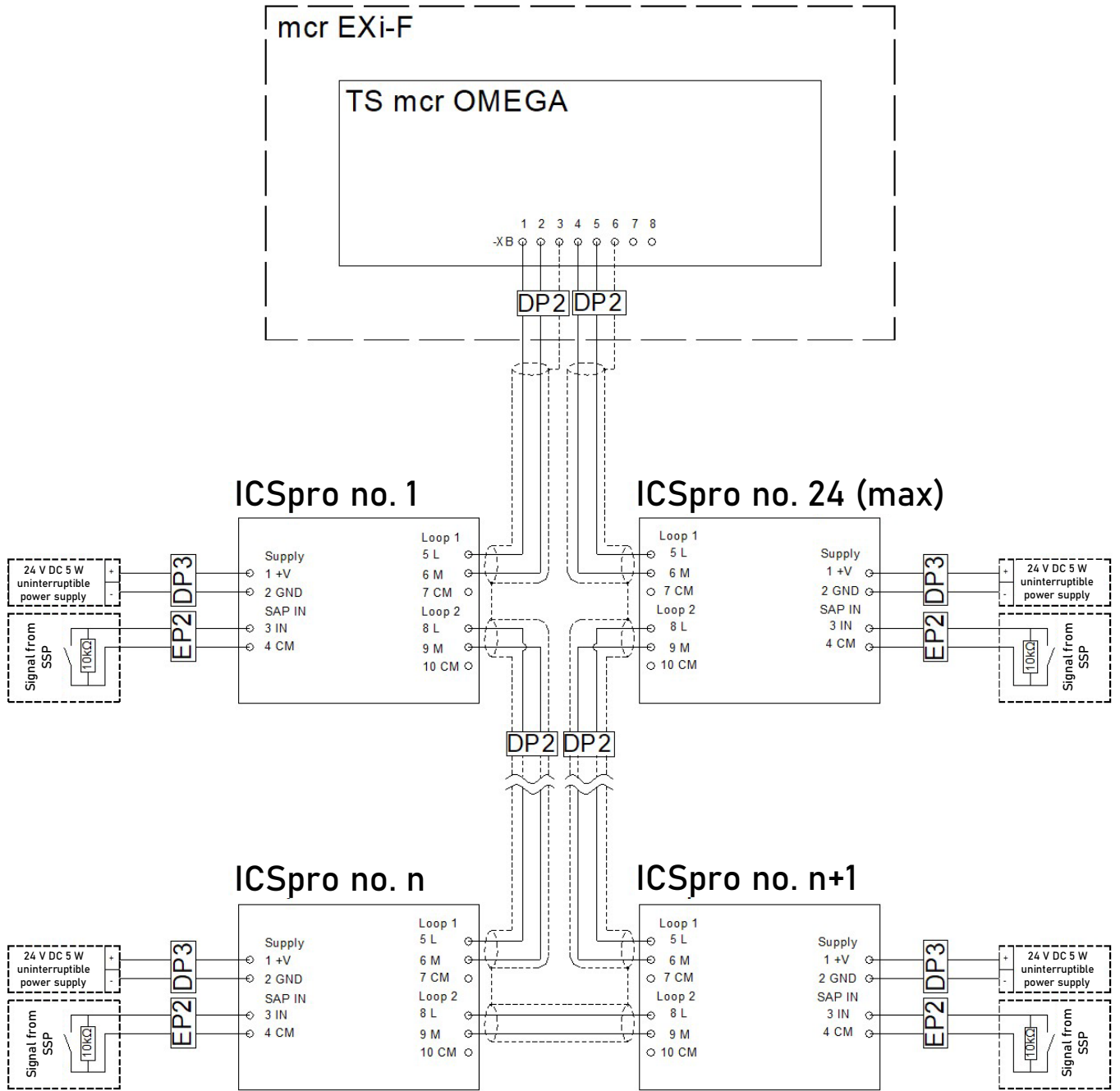

Figure 61 Block diagram for connecting mcr ICS Pro pressure transmitters in a lobby setup.

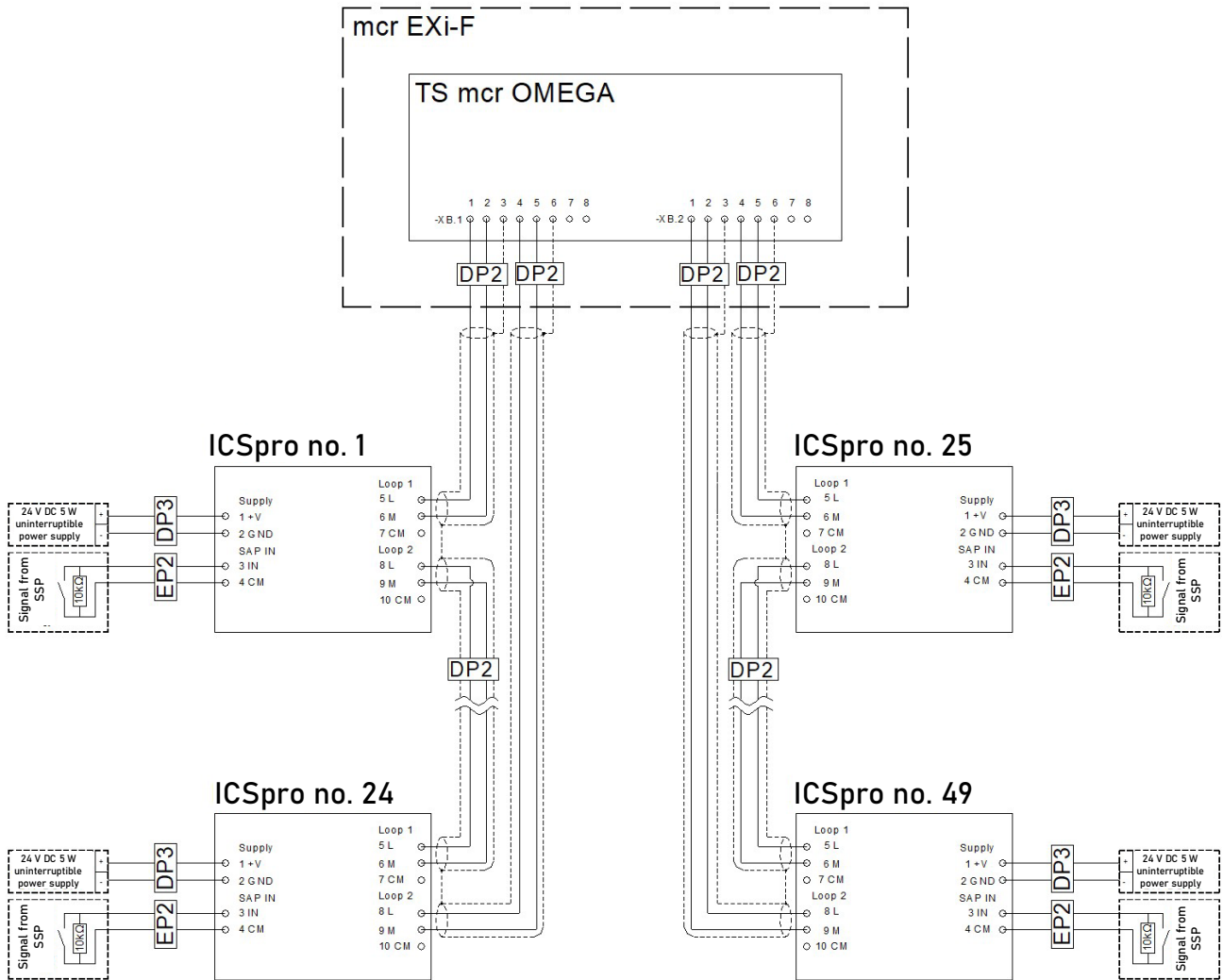

Figure 62 Block diagram for connecting mcr ICS Pro pressure transmitters in a lobby setup connected in two communication loops.

6.1. Electrical connections of devices to the mcr Omega panel

6.1.1. EXi-F unit air supply fan

Control panels are dedicated automation systems (selected based on the fan power) for each mcr EXi-F air supply unit. Detailed connection diagrams are provided with each control panel in the form of an attached document and stickers on the internal side of the mcr Omega cabinet door.

The fan motor is supplied with 3x400 V AC from the mcr Omega panel.

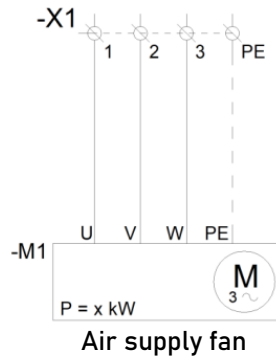

Figure 63 Fan connections circuit diagram.

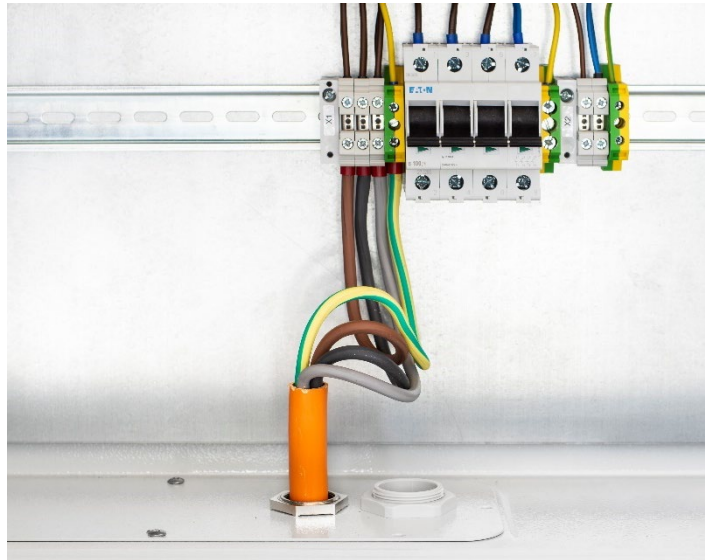
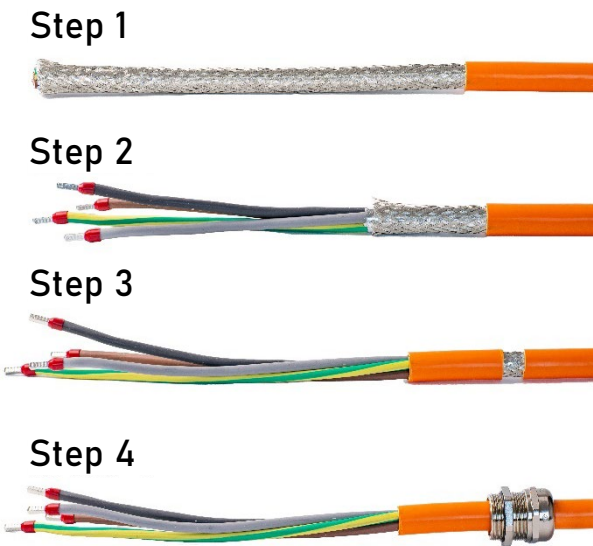

Figure 64 Step by step wire preparation guide.

6.1.2. Service disconnector

mcr EXi-F air supply units may be equipped with service disconnectors, which are used to disconnect power supply to the fan if an inspection or maintenance is necessary.

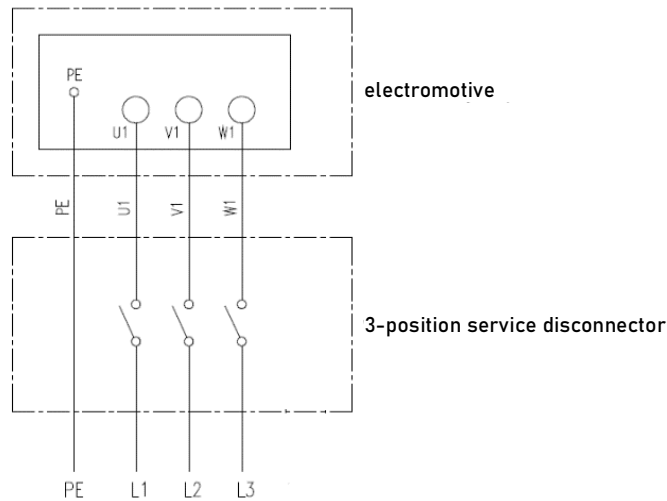

Figure 65 Electrical diagram of the service disconnector for the air supply unit fan.

CAUTION:

Using the service disconnector during operation of the air supply unit is prohibited. Using a service disconnector when an air supply unit is in operation will damage the rpm regulator located on the mcr Omega control panel.

6.1.3. Shut-off damper

mcr EXi-F system air supply units may be equipped with multi-blade dampers with a BF/BFL/BFN or Mercor MF/MLF series actuator. When no alarm is active, the damper remains closed, preventing heat seeping from the protected space. Loss of voltage causes the dampers to open (safe position).

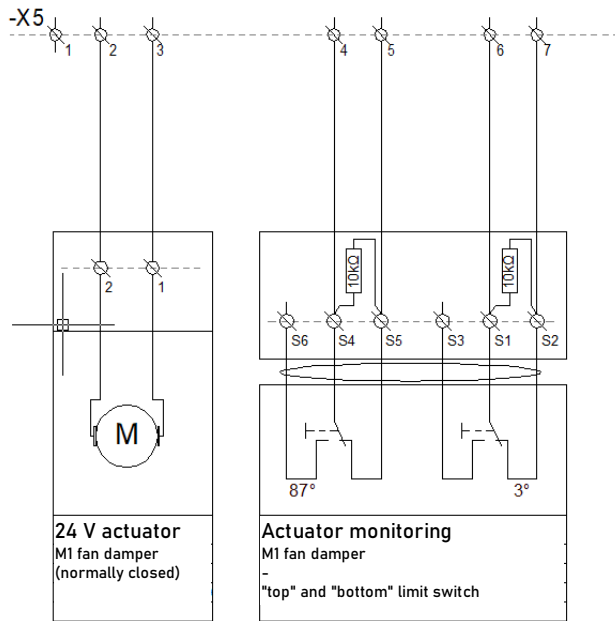

Figure 66 Shut-off damper actuator connections circuit diagram.

6.1.4. mcr PLD explosion pressure relief panels

As standard, devices are equipped with multi-blade dampers (material: aluminum, type: reverse-action) with an actuator (type: BF /BFL /BFN, 24 V DC power supply), which are used as elements that counteract the free flow of air while the devices are not in operation.

Loss of voltage causes the dampers to open (safe position).

The kit may also be equipped with anti-icing systems.

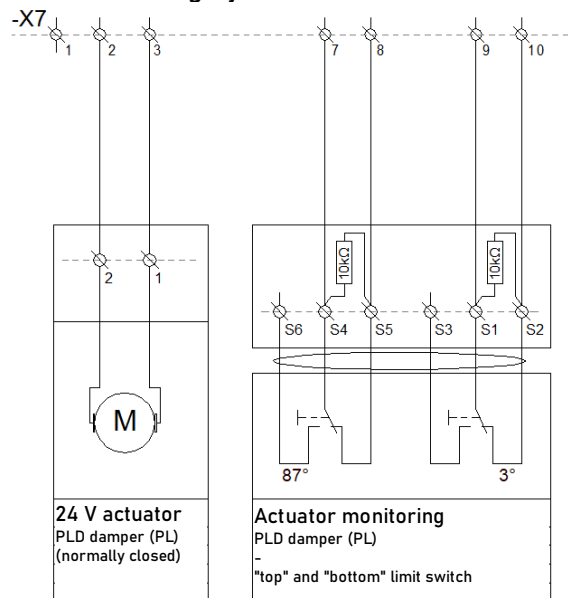

Figure 67 Connections circuit diagram for the Belimo BF, BFL, BFN series actuator.

6.1.5. mcr RPC system permanent unsealing module

As standard, devices are equipped with multi-blade dampers with an actuator (type: BF /BFL /BFN, 24 V DC power supply), which are used as elements that counteract the free flow of air while the devices are not in operation. Loss of voltage causes the dampers to open (safe position).

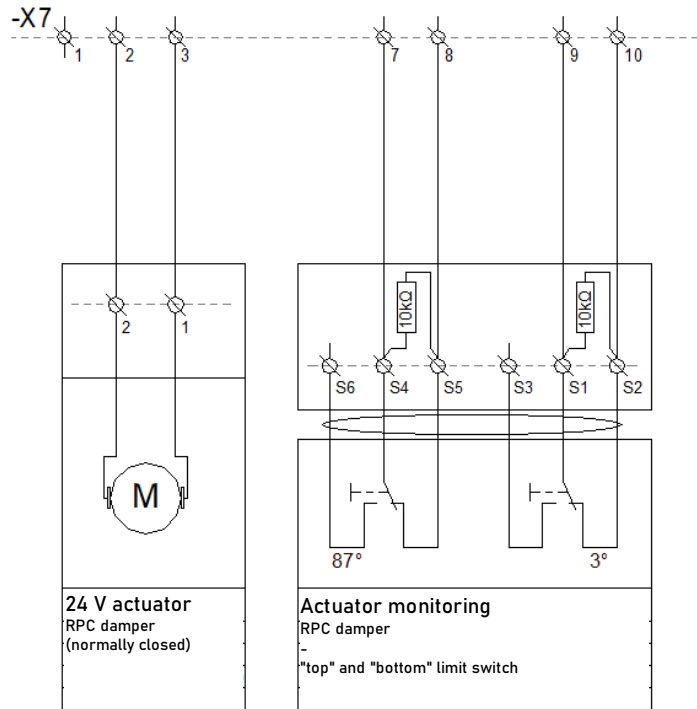

Figure 68 mcr RPC connections circuit diagram.

6.1.6. Connection of the mcr Omega control panel from FSS

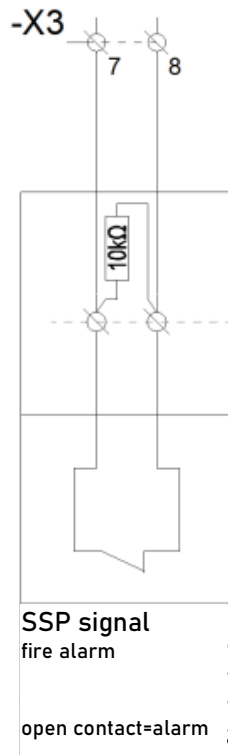

Figure 69 Connection of SSP signal (fire ALARM) to the EXi-F panel.

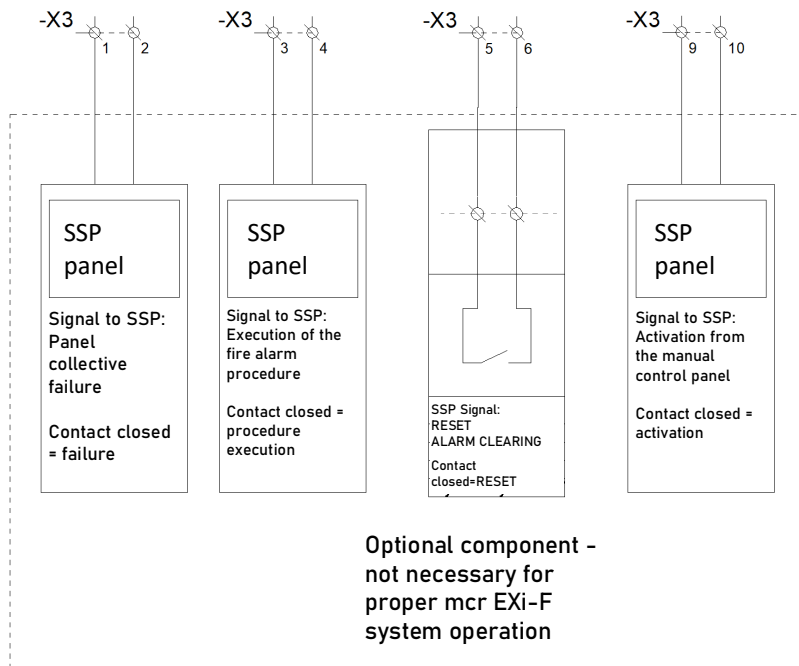

Figure 70 Connecting optional SSP signals to the mcr Omega panel.

6.1.7. Connection diagram for automation with backup fan

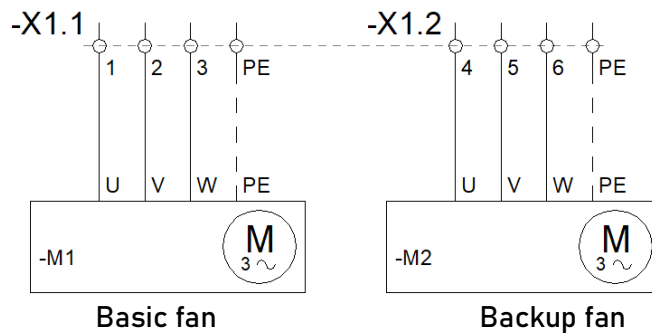

Figure 71 Fans connections circuit diagram.

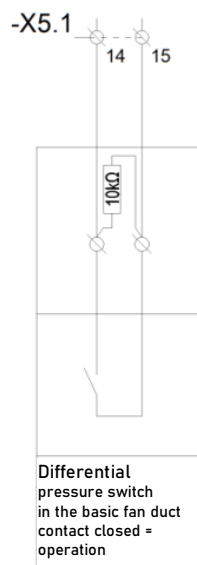

Figure 72 Pressure switch connections circuit diagram.

6.1.8. Automation connection diagram for vertical fans

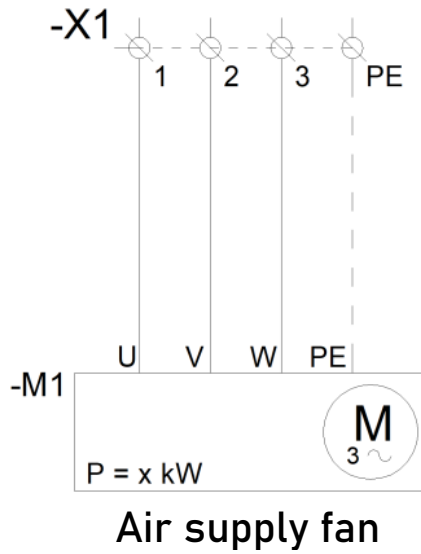
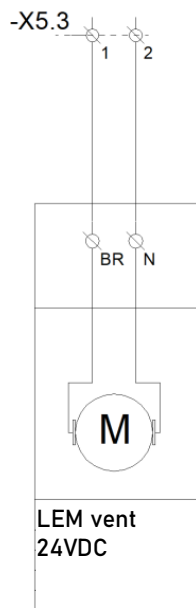

Figure 73 Fan connections circuit diagram



Vent opening - brown, - blue
 Vent closing - - brown "+" - blue

Figure 74 Circuit diagram for wiring the LAM vent.

mcr LAM connection specifications			
Type of element	Feature	Power supply unit	Cable types (suggested for up to 50 m)
mcr LAM	Power supply	mcr Omega panel	HDGs 2x2,5

6.1.9. Automation connection diagram for switching system / double intake vent

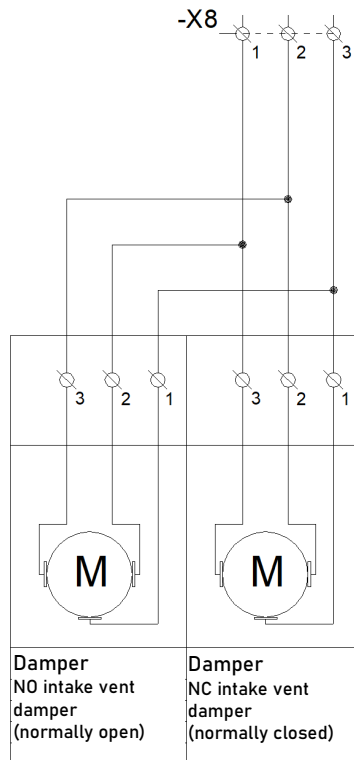
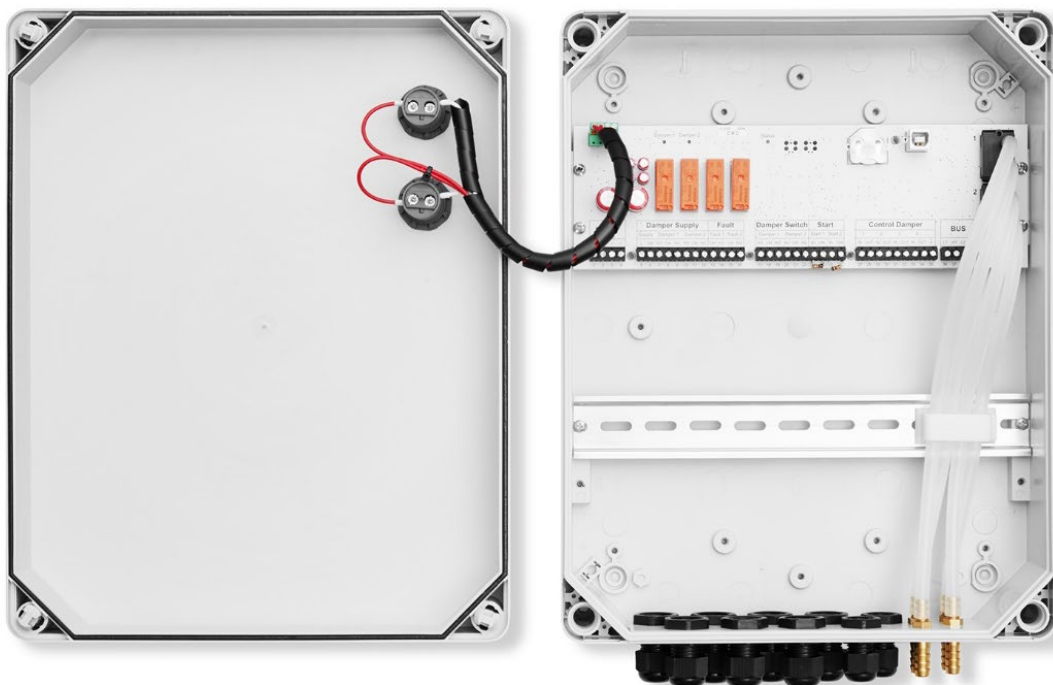

Figure 75 Connections circuit diagram for two dampers in the intake vent switching system.

6.1.10. Automation connection diagram for lobby system



An example connection diagram is presented in Figure 31. Actuators are connected to the regulator only through a dedicated connection box. The box is equipped with a thermal fuse. The total length of cables between the regulator and the actuator must not exceed 15 m.

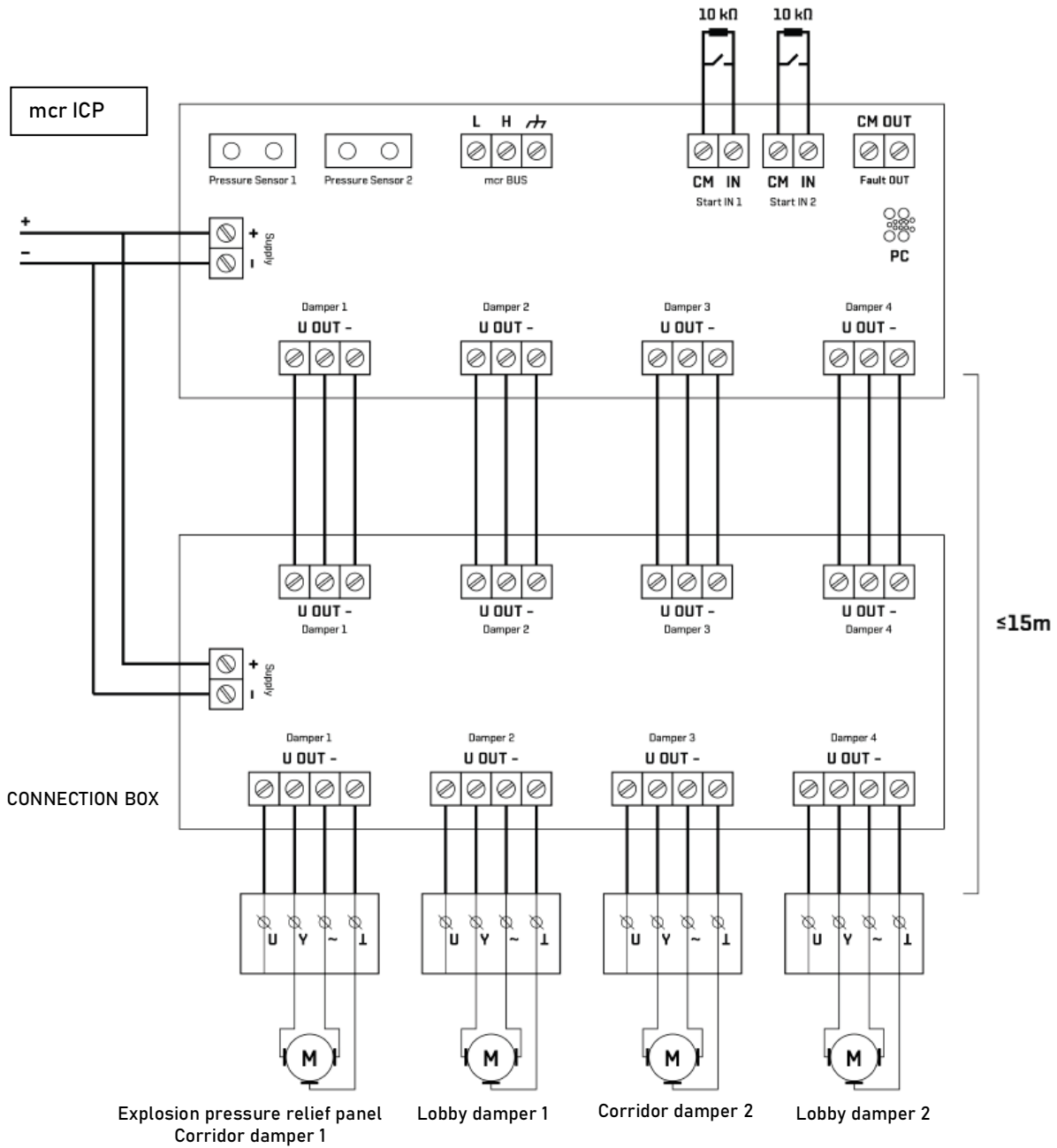

Figure 76 General block diagram for connecting mcr ICP and mcr PP regulators (support for 4 lobby dampers).

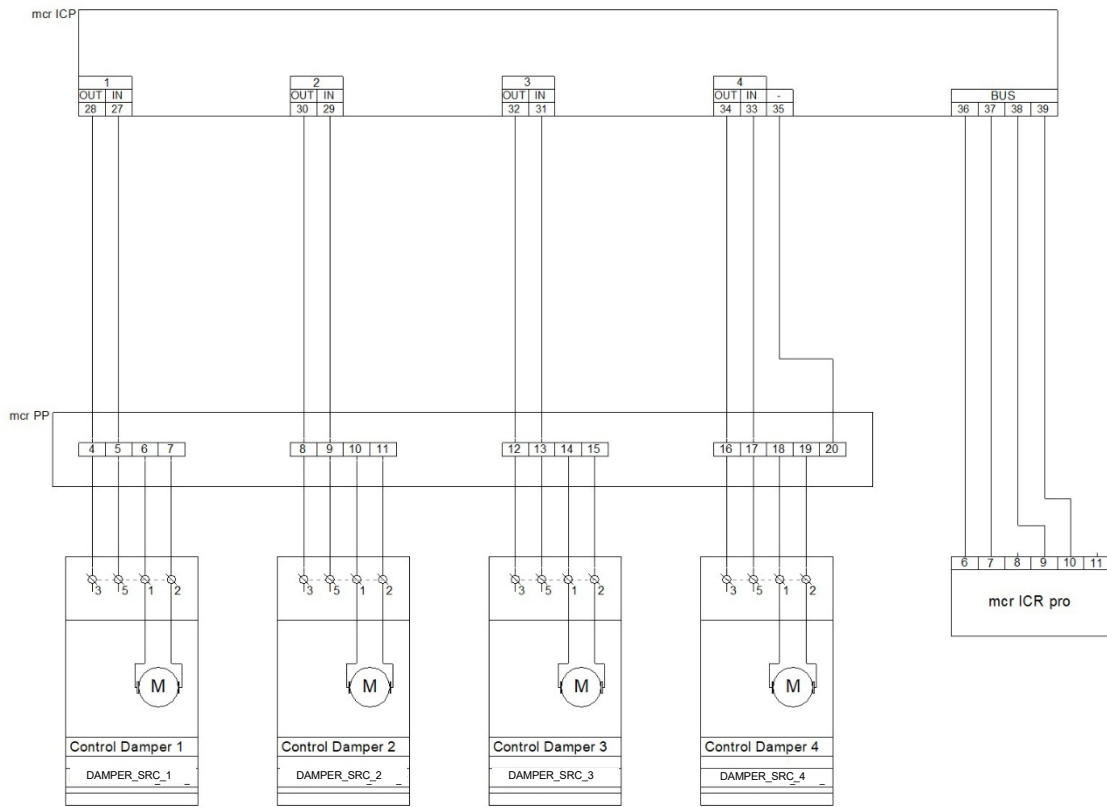

Figure 77 Block diagram for connecting a mcr ICP regulator in the communications network with mcr Omega.

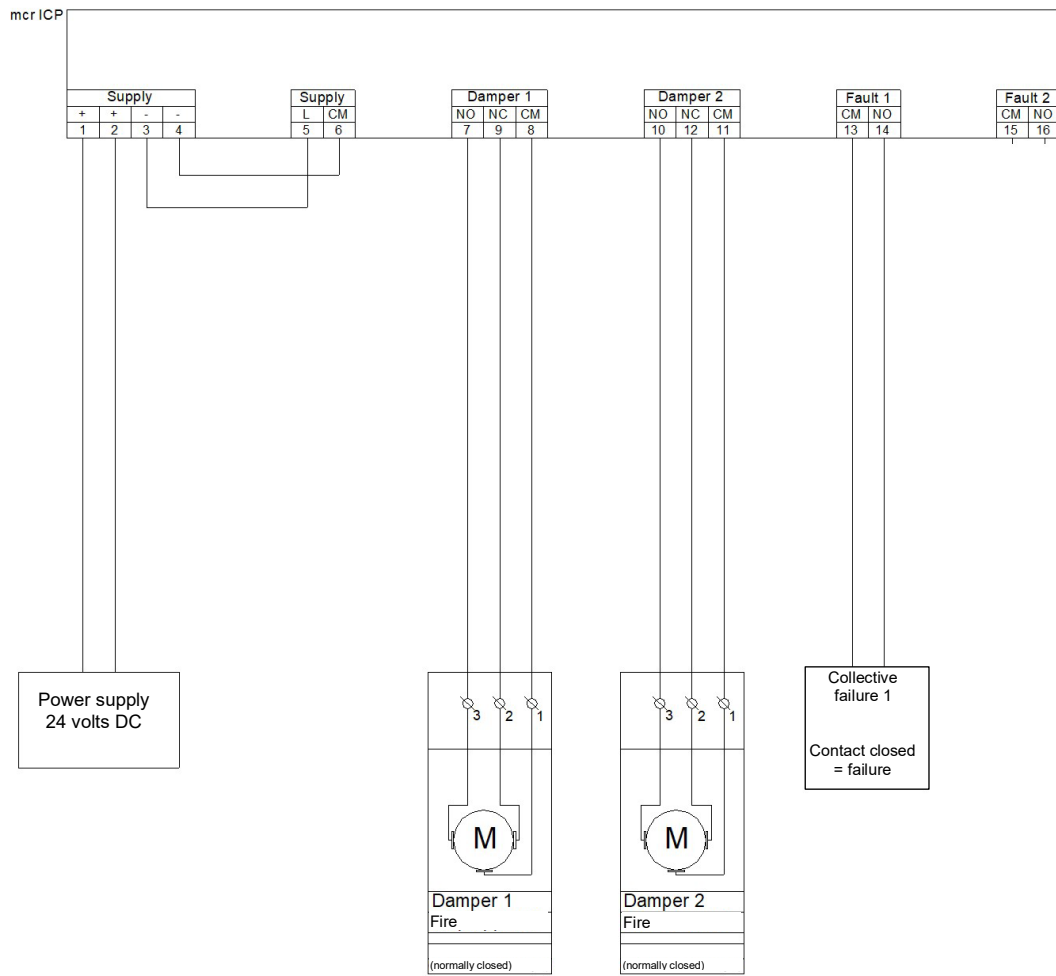

Figure 78 Block diagram for connecting a mcr ICP regulator – option with support for fire ventilation vents.

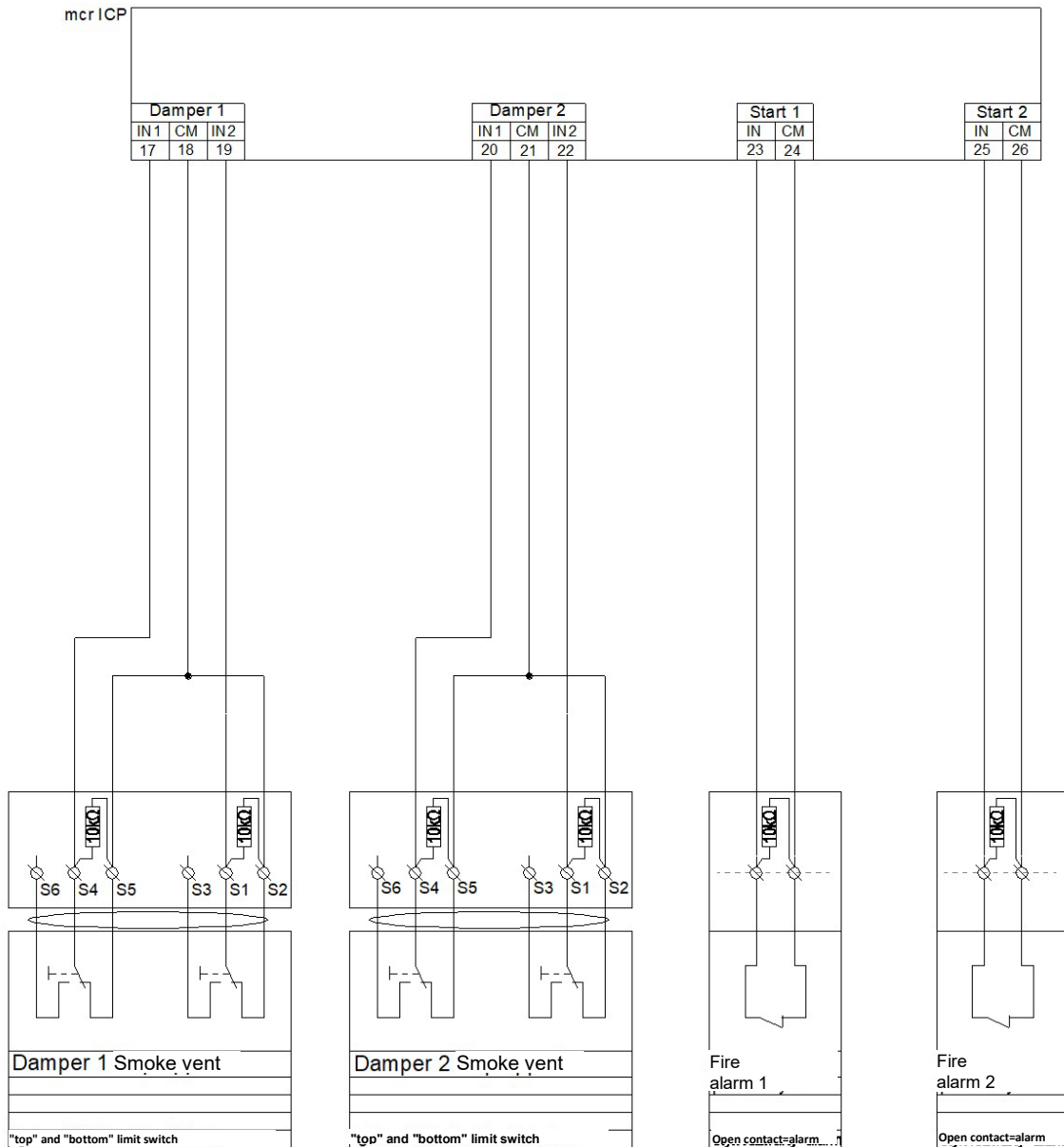

Figure 79 Connection diagram for fire ventilation vent limit switches and SSP alarms.

CAUTION:

A regulator that has not yet been configured is working as an explosion pressure relief panel and is configured to maintain an overpressure of 50 Pa. The mcr ICR pro regulator is only visible in the configuration application from the mcr ICR level once an address has been assigned to it (set in the controller configuration application). Changes may only be introduced into the mcr ICP lobby regulators configuration from the configuration application once they are physically connected to a computer. It is only possible to view the status (operation parameters configured) of the controller from the mcr ICR configuration application. If the default setting is not appropriate, modify the controller configuration. The first step is to select the proper operating mode and to assign an address to the controller in case of network operation. Then, for modes II, III and IV, calibration must be performed. Failure to perform calibration is indicated by a red indicator light on the device and in the app. Without calibration, the device will not respond to signals from the FSS system.

The above works are performed by authorized "MERCOR" S.A. service.

NMQ/LMQ/SMQ actuators are installed in the case of dampers used for lobby systems, where high-speed dampers are used.

6.1.11. mcr ICS pro differential pressure transmitter

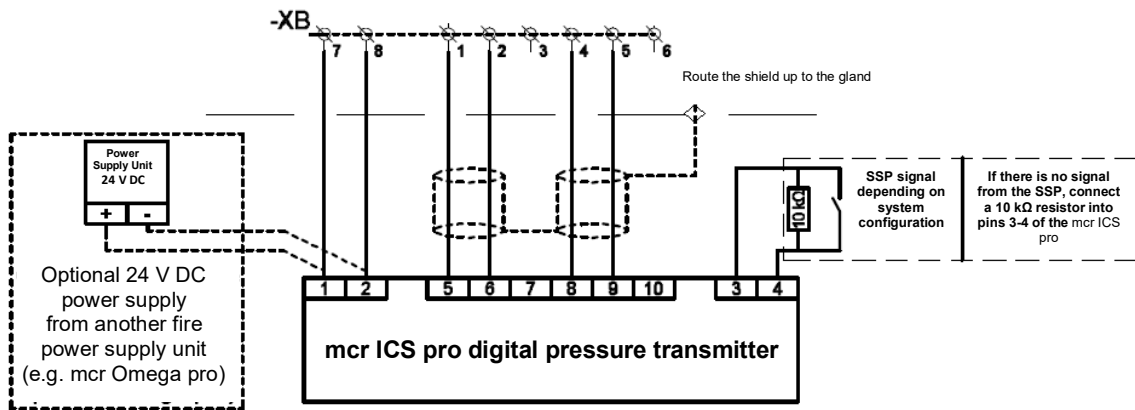

Figure 80 mcr ICS pro differential pressure transmitter connections circuit diagram

Transmitters working in a lobby setup should have proper addresses assigned. For this purpose, a code setter located on a board inside the device is used:



Code setter setup	No jumper or jumper on the left side	Jumper in the ADDR+10 position (right side)
0	0	10
1	1	11
2	2	12
3	3	13
4	4	14
5	5	15
6	6	16
7	7	17
8	8	18
9	9	19
A	10	20
B	11	21
C	12	22
D	13	23
E	14	(!) 23
F	15	(!) 23

Transmitters with the proper addresses assigned can be quickly located, which significantly reduces the system configuration and adjustment time as per the Following explanation:

- level " 0" - address 0, level "+1" - address 01, etc.
- level "-1" - address 21, level "-2" - address 22, etc.

CAUTION:

Remember about the end-of-line (INPUT) resistors - 10 kΩ, supplied with the device.

6.1.12. mcr PSR / mcr PSRC manual control panel

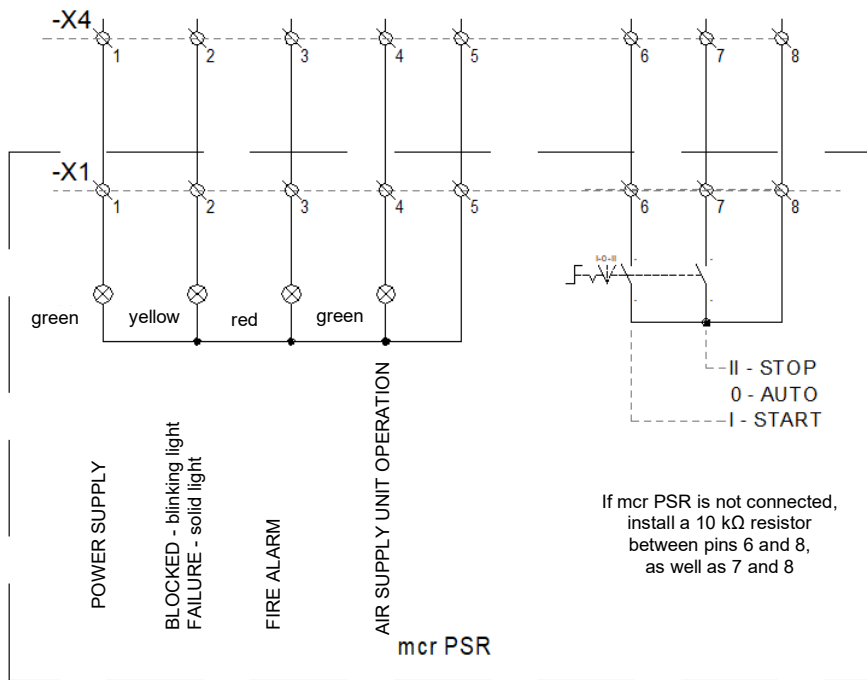

Figure 81 mcr PSR manual control panel connections circuit diagram.

mcr Omega

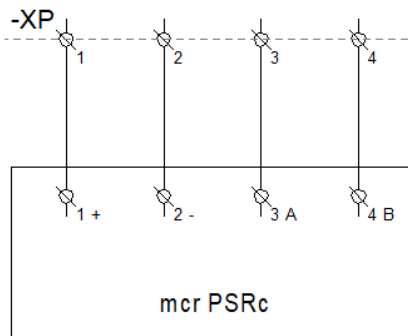

Figure 82 mcr PSRC manual control panel connections circuit diagram.

Proper mcr PSRC operation requires an RS485 expansion card to be inserted into the mcr MMS pro [A0] module. In order to activate mcr PSRC control from the panel, set the S5 switch into position II.

6.1.13. mcr WPS elevated control panel

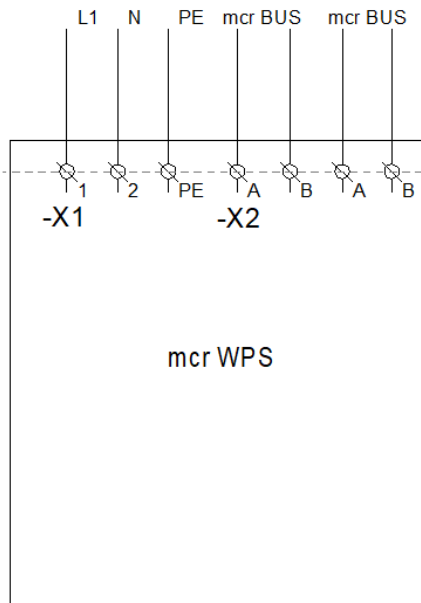

Figure 83 Electrical connection of the mcr WPS panel (U=230 V AC).

6.1.14. Duct smoke detector

The duct smoke detector is equipped with relay outputs that signal an alarm (smoke detection) and signal a technical alarm (service/failure, only for the UG-3-A4 sensor).

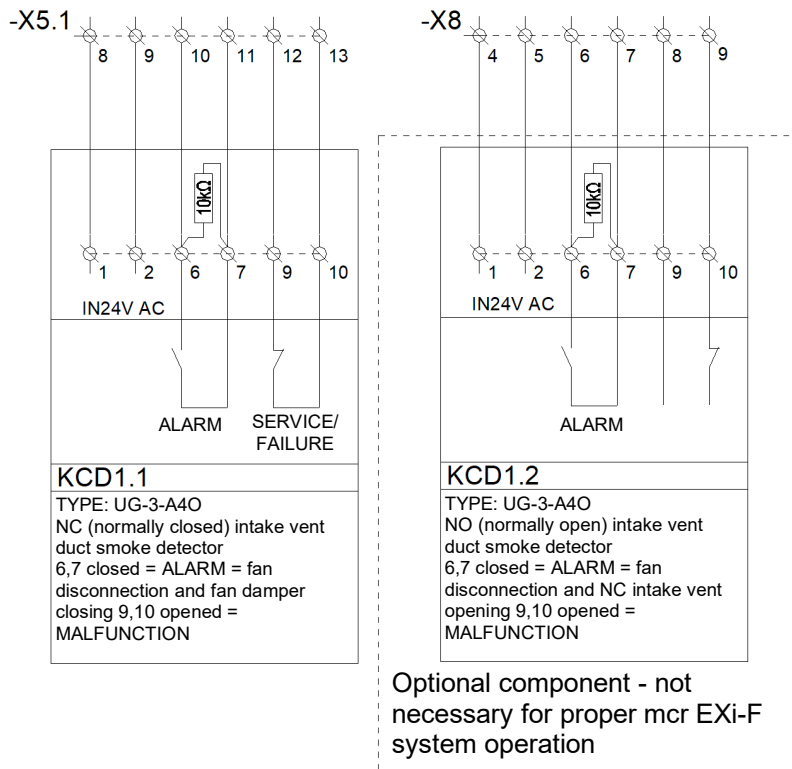

Figure 84 UG-3-A4 duct smoke detector connections circuit diagram.

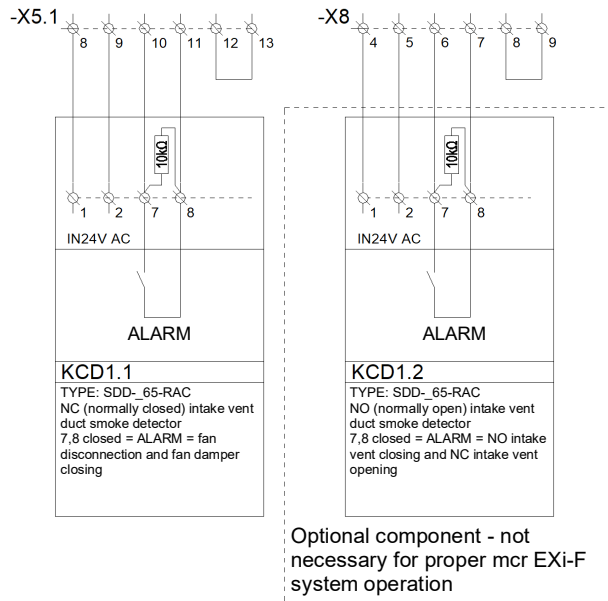

Figure 85 SDD-65-RAC duct smoke detector connections circuit diagram.

6.1.15. mcr HT anti-icing system

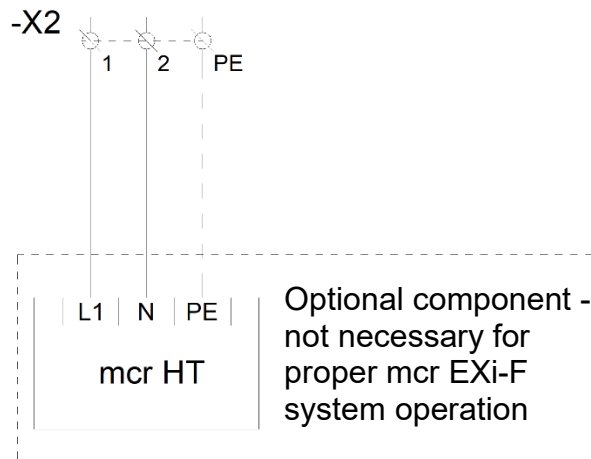

Figure 86 Electrical connection of the mcr Omega panel for the anti-icing system.

6.1.16. Connection of mcr EXi-F actuators

6.1.16.1. Actuators with return spring

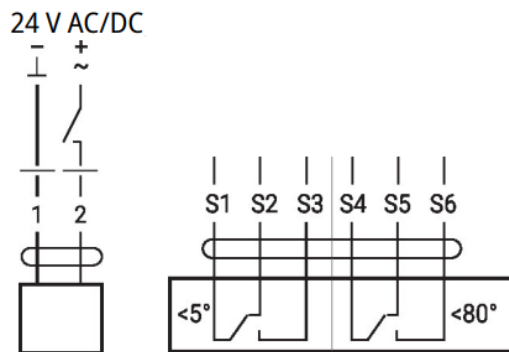

Figure 87 Connections circuit diagram for the Belimo BF/BFL/BFN series actuator. Actuators used in shut-off dampers at mcr EXi-F air supply units.

6.1.16.2. Actuators without return spring

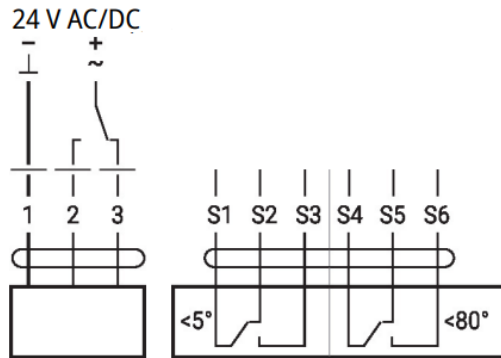

Figure 88 Connections circuit diagram for the Belimo BE/BEE/BLE series actuator. Actuators used in dampers in double intake vent systems.

6.1.16.3. High-speed actuators for the mcr ICP lobby regulator

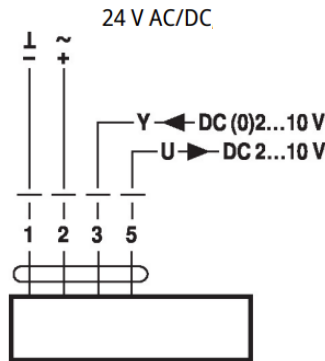
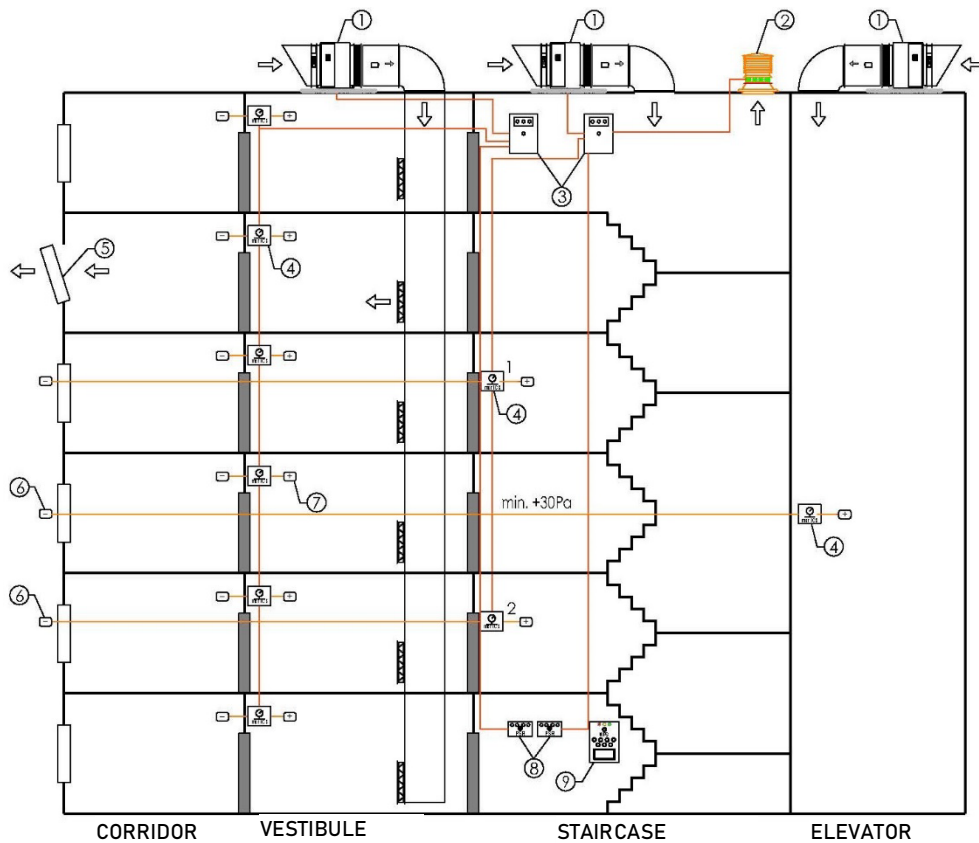

Figure 89 Connections circuit diagram for the Belimo NMQ/LMQ/SMQ series actuator.

7. PNEUMATIC CONNECTION

An outdoor pressure system should be routed in silicone tubing (resistant to low temperatures) with an internal diameter of 8 mm and a maximum length of 12 m. Endings of hydraulic lines should be secured against accidental obstruction. This purpose is fulfilled by protection boxes - pressure measurement points supplied with the mcr ICS transmitter. Correct polarity '+' - space with increased pressure, '-' reference space.

When routing pressure lines, special attention should be paid to the method of installation. Lines should be laid with a slope from the mcr ICS transmitter towards the pressure measurement points. Lines should not be installed in a way that reduces flow. It is recommended to use connecting elements and route pressure lines in installation tubing, e.g. RL surface-mounted or flush-mounted, as additional protection against mechanical damage.



- ① air supply unit with damper and smoke detector
- ② mcr RPC protected space unsealing module (optional)
- ③ mcr Omega control panel(s)
- ④ differential pressure transmitter
- ⑤ air relief
- ⑥ pressure measurement point located in the external area
- ⑦ pressure measurement point located in the usable floor space
- ⑧ PSR manual control panel
- ⑨ WPS elevated control panel
- ⇒ air flow direction
- cabling



Figure 90 Principle for routing pressure hoses.

When pressure measurement points are located at a significant distance from the pressure transmitter, an additional set of hoses with a length of 5 m and a diameter of 8 mm may be used (maximum total length of pressure hoses should not exceed 12 m). An additional set of hoses is equipped with 4 connecting elements (2 elbow connectors, 2 straight connectors).

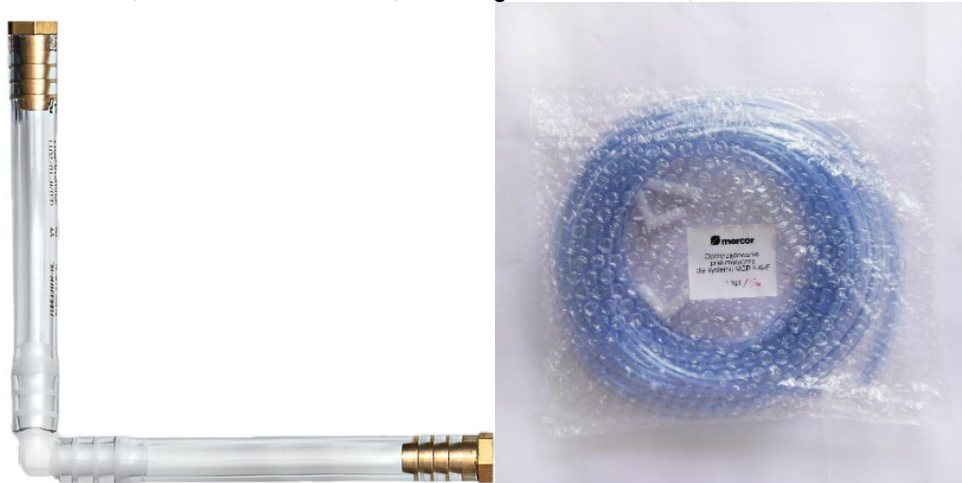

Figure 91 Additional set of pressure hoses with accessories.

7.1. Connection of a mcr ICS pro differential pressure transmitter

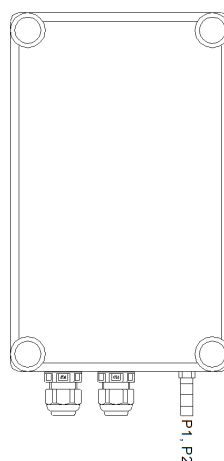

Figure 92 View of the mcr ICS pro differential pressure transmitter.



Figure 93 Pressure measurement points.

7.2. Connecting the mcr ICP lobby regulator

The device offers two input pairs that receive silicone hoses leading to zones where the pressure difference is to be measured. The first two connections on the right are for zone 1 (P1 upper input, P2 lower input), while the other two connections are for zone 2 (P3 upper input, P4 lower input).

- P1 - space with increased pressure - lobby
- P2 - reference space - corridor 1
- P3 - space with increased pressure - lobby
- P4 - reference space - corridor 2

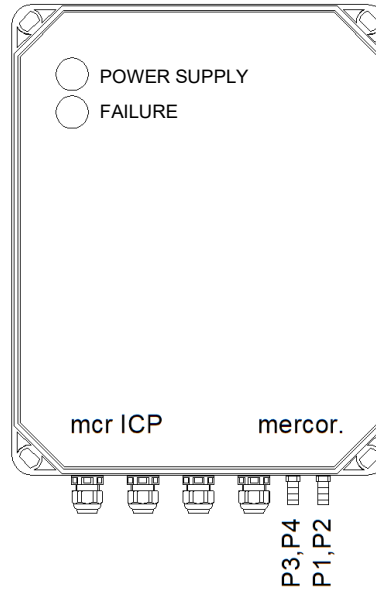
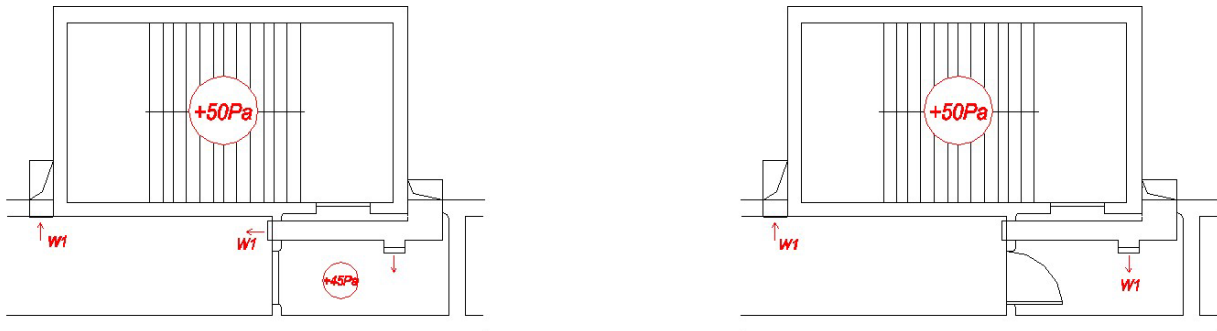
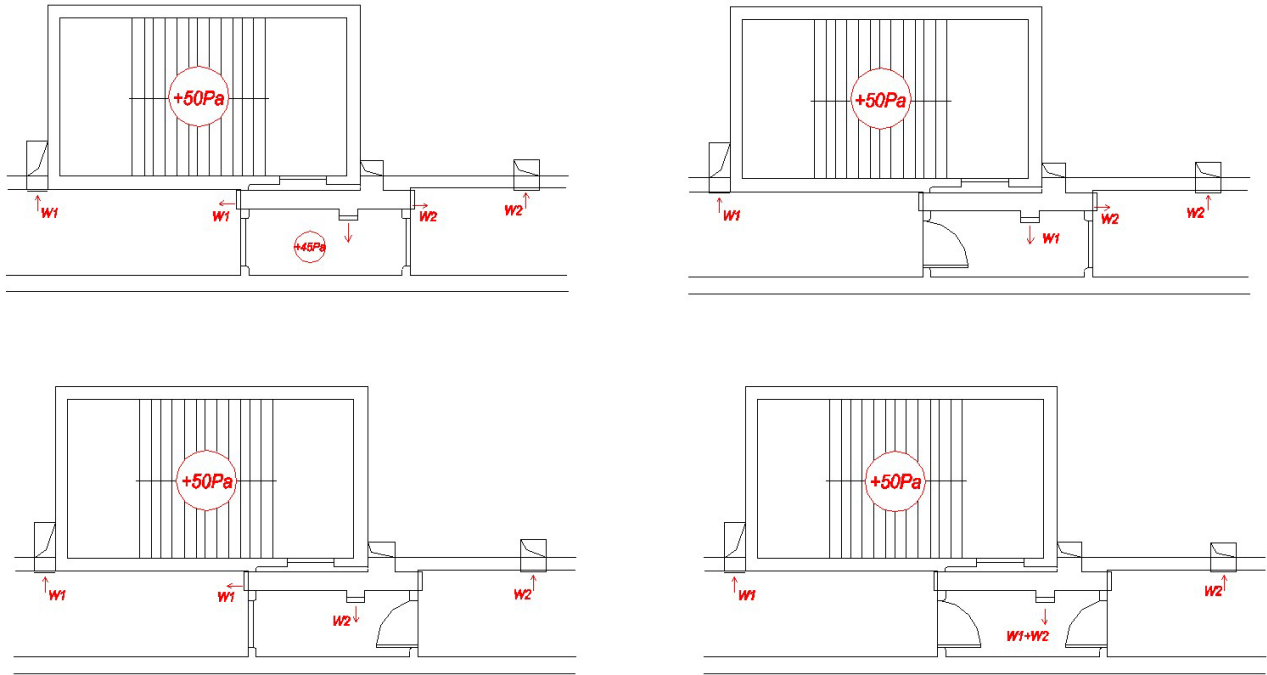

Figure 94 View of the mcr ICP lobby regulator.

Lobby with one corridor



Lobby with two corridors



8. MECHANICAL CONNECTION OF SYSTEM COMPONENTS

8.1. mcr Monsun air supply units

The following diagram presents standard horizontal installation of a set of mcr EXi-F system components. The type and number of components may be different than what is presented in the figure, depending on the selected final system configuration.

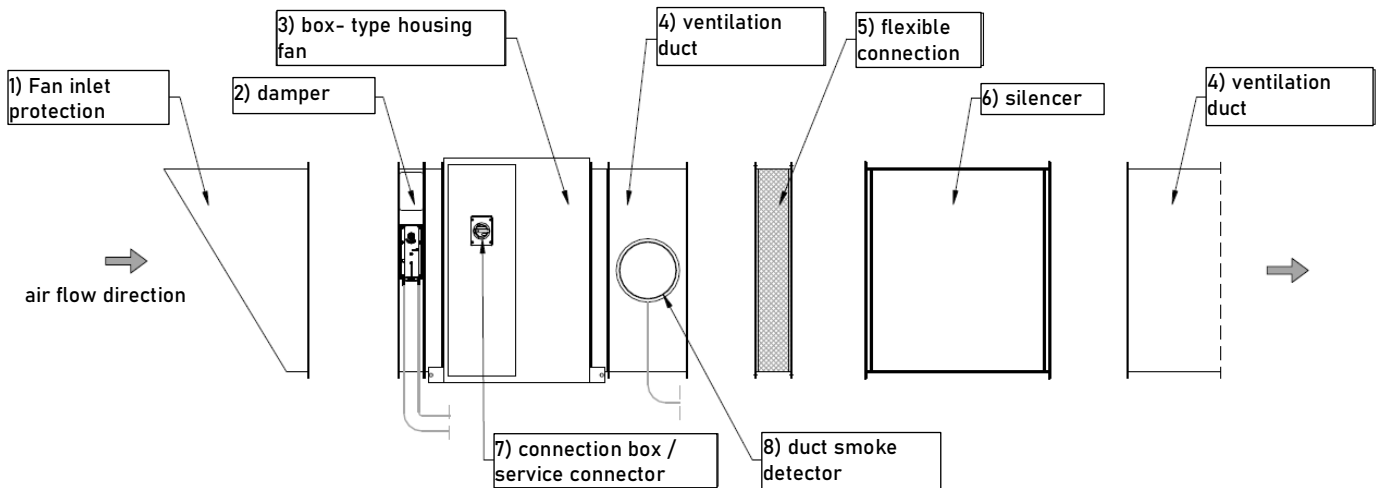

Figure 95 Sample standard horizontal installation of a set of mcr EXi-F system components: 1 - fan inlet protection, 2 - damper, 3 - mcr Monsun E1 fan in a box-type housing 4 - ventilation duct (pipe), 5 - flexible connection, 6 - silencer, 7 - connection box / service connector, 8 - duct smoke detector.

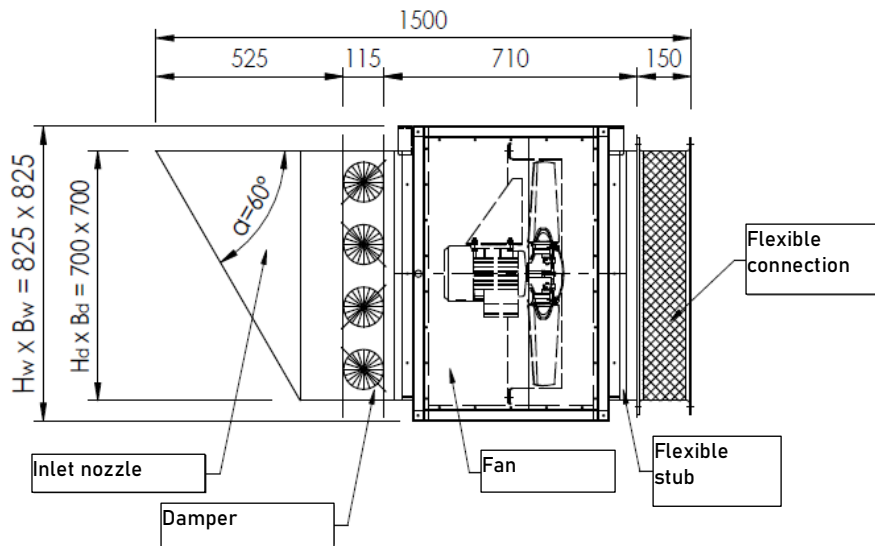

Figure 96 Basic dimensions of the standard mcr EXi-F 63-1 air supply units in a box-type housing - horizontal installation.

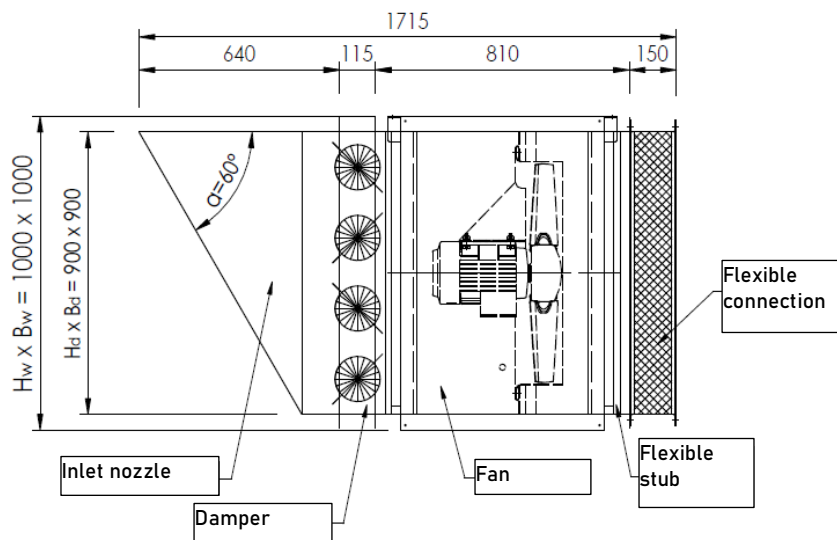

Figure 97 Basic dimensions of the standard mcr EXi-F 80-1S, 71-1S, 71-2S air supply units in a box-type housing - horizontal installation.

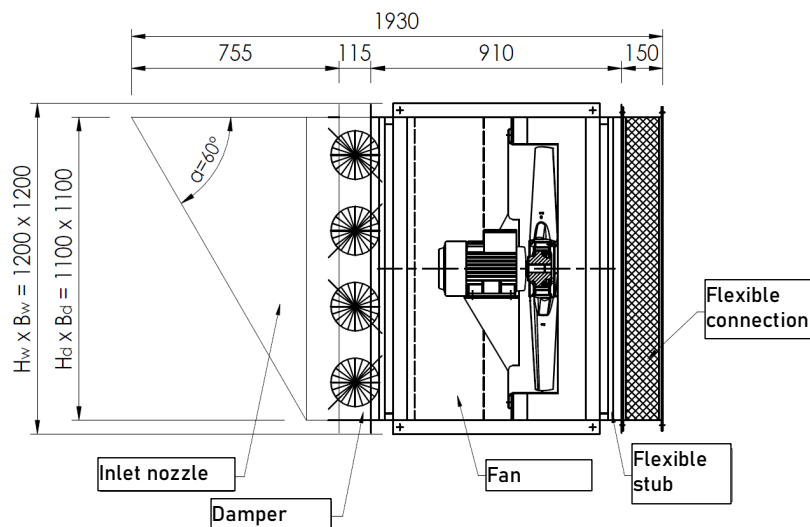

Figure 98 Basic dimensions of the standard mcr EXi-F 90-1S, 90-2S, 100-1S, 100-2S air supply units in a box-type housing - horizontal installation.

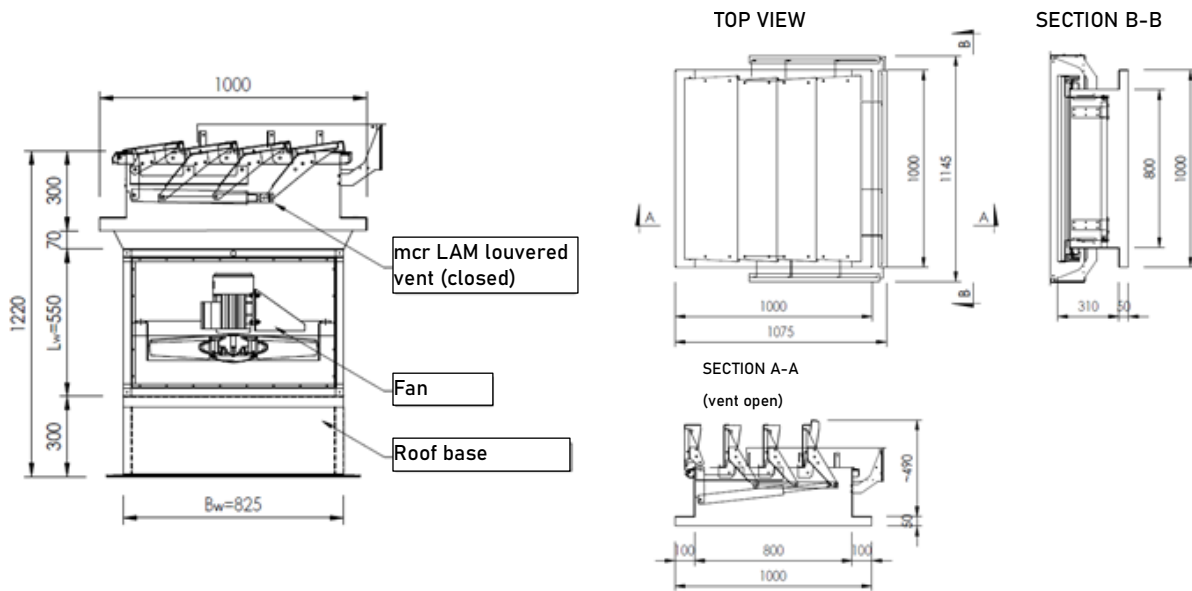

Figure 99 Vertical installation with louvered vent: mcr EXi-F 63- 1S UP.

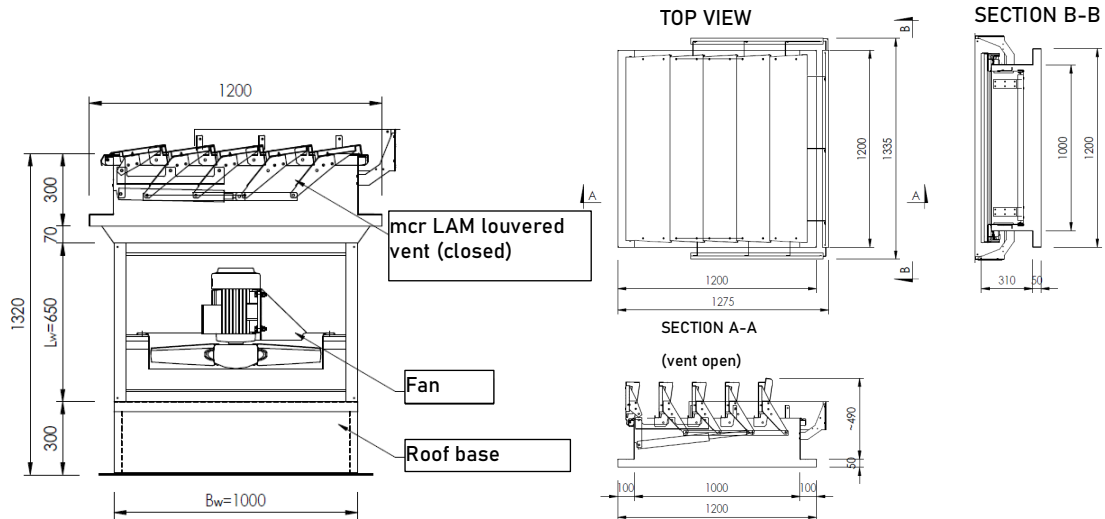

Figure 100. Vertical installation with louvered vent: mcr EXi-F 71-1S UP, 71-2S UP, 80-1S UP.

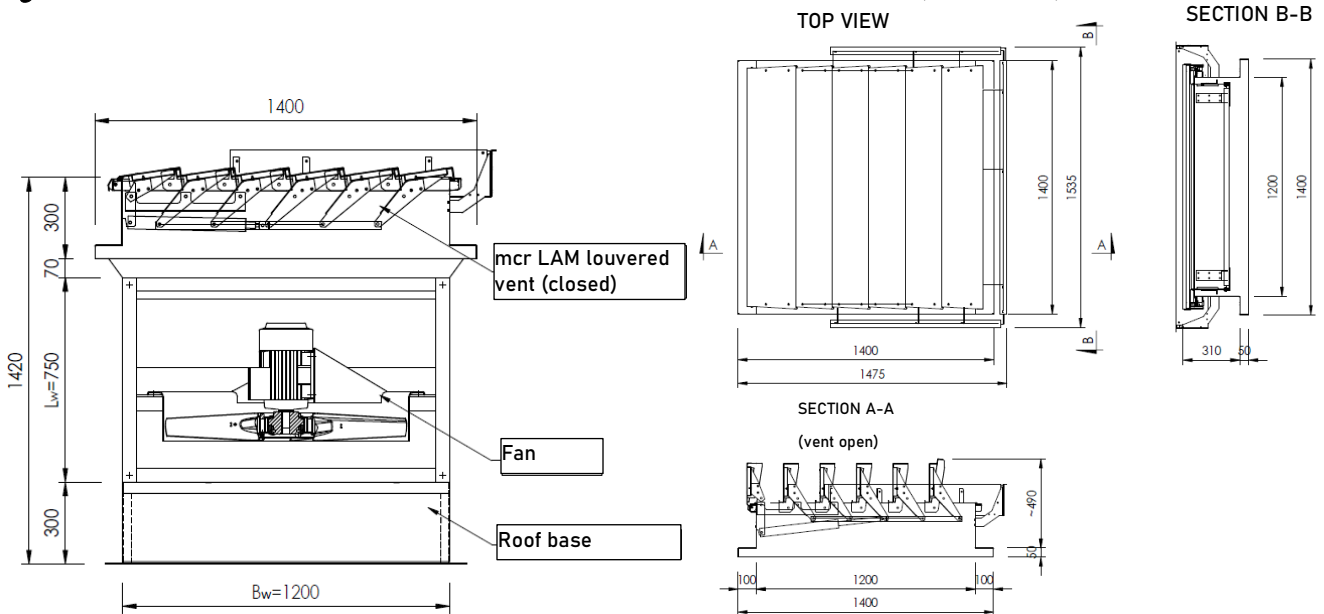

Figure 101 Vertical installation with louvered vent: mcr EXi-F 90-1S UP,90-2S UP,100-1S UP,100-2 S UP.

Prior to installing a vertical system, an opening should be prepared in the ceiling, as per the technical design.

Type	maximum ceiling opening
mcr EXi-F 63-1S UP	700x700
mcr EXi-F 70-1S UP, 70-2S UP, 80-1S UP	900x900
mcr EXi-F 90-1S UP, 90-2S UP, 100-1S UP, 100-2S UP	1100x1100

8.2. Control panel mcr Omega

As a standard, the control panel is attached to the wall using installation studs or to installation systems using 4xM10 screws.

8.3. mcr ICS pro differential pressure transmitter

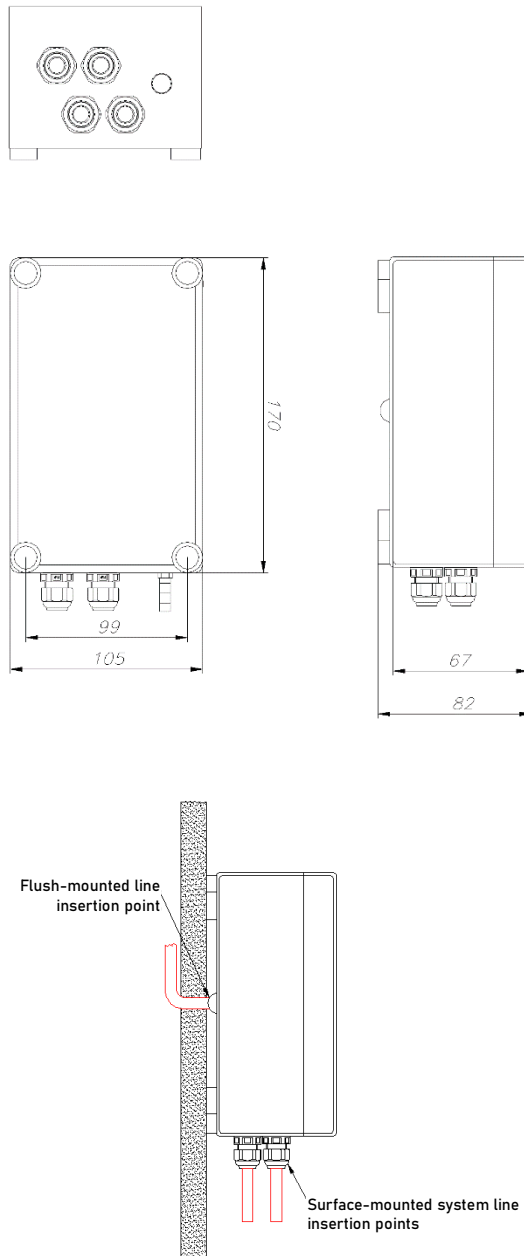

Figure 102 ICS pro transmitter installation dimensions.

8.4. mcr PSR / mcr PSRC manual control panel

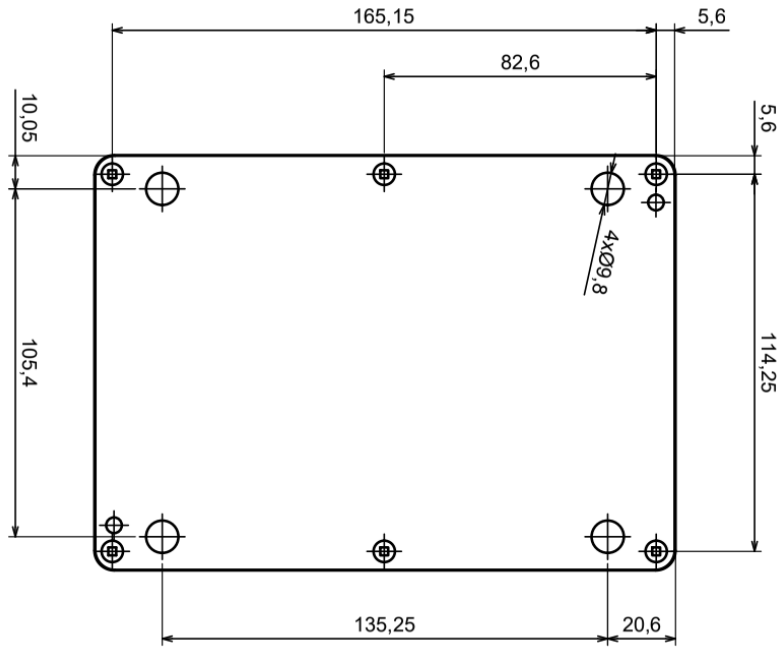

Figure 103 Dimensions of available mcr PSR/PRSC installation holes.

PSR may be installed with the sides adjacent - housings have beveled openings for wires that may be routed between panels.

8.5. Duct smoke detector

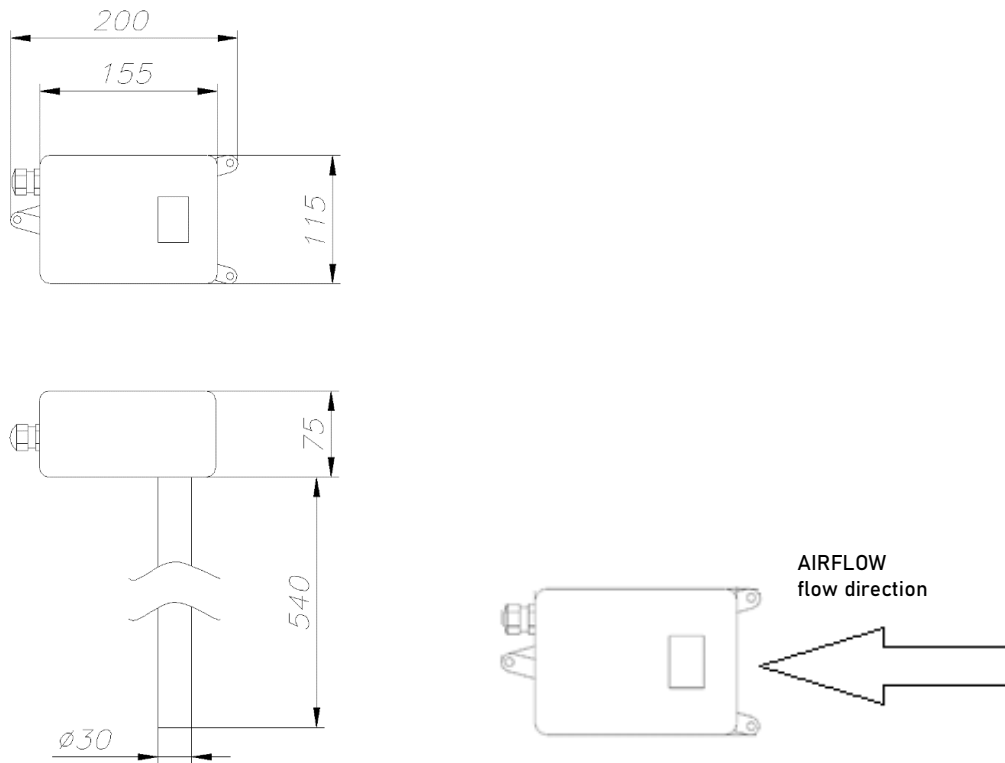

Figure 104 Installation rules along with dimensions of the SDD series sensor.

8.6. mcr ICP lobby regulator

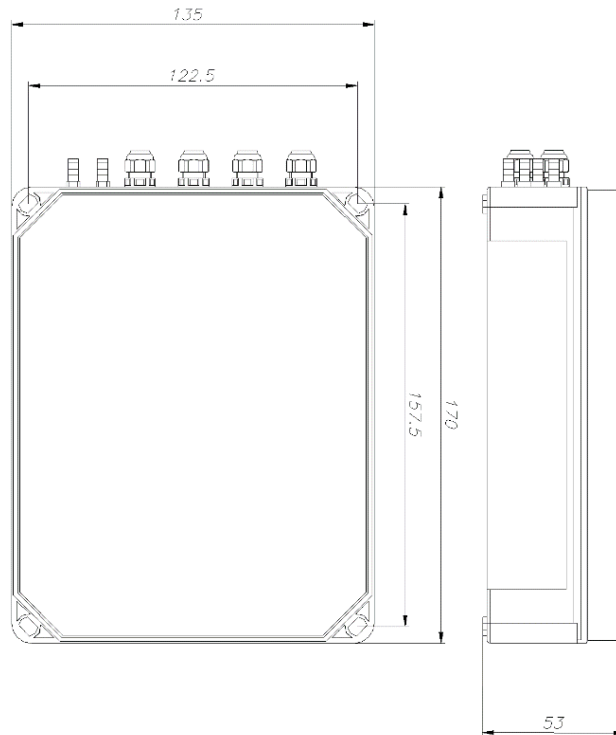

Figure 105 Dimensions of mcr ICP regulator installation holes.

8.7. mcr PP connection box

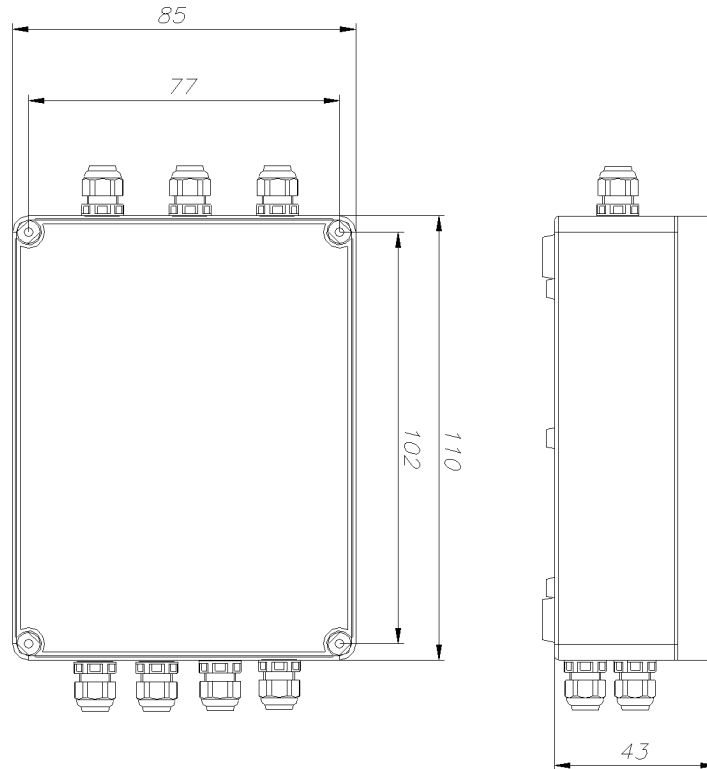

Figure 106 Dimensions of mcr PP connection box installation holes.

mcr SEP network separators

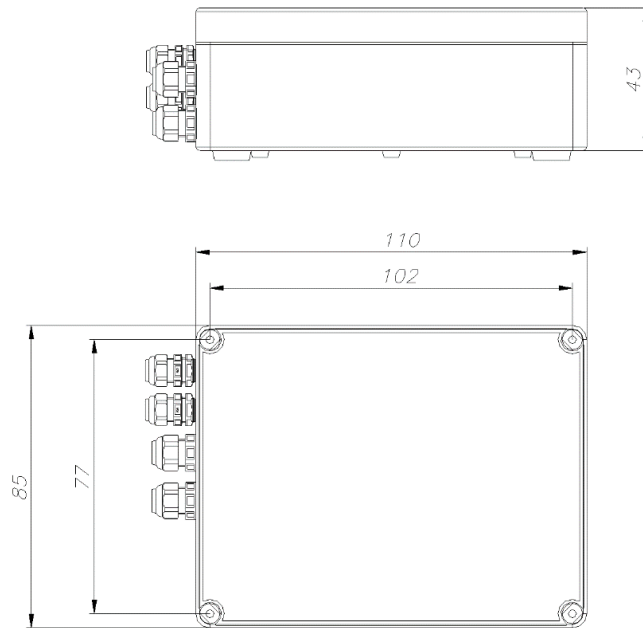

Figure 107 Dimensions of mcr SEP network separator installation holes.

8.8. Magnetic sensors (reeds)

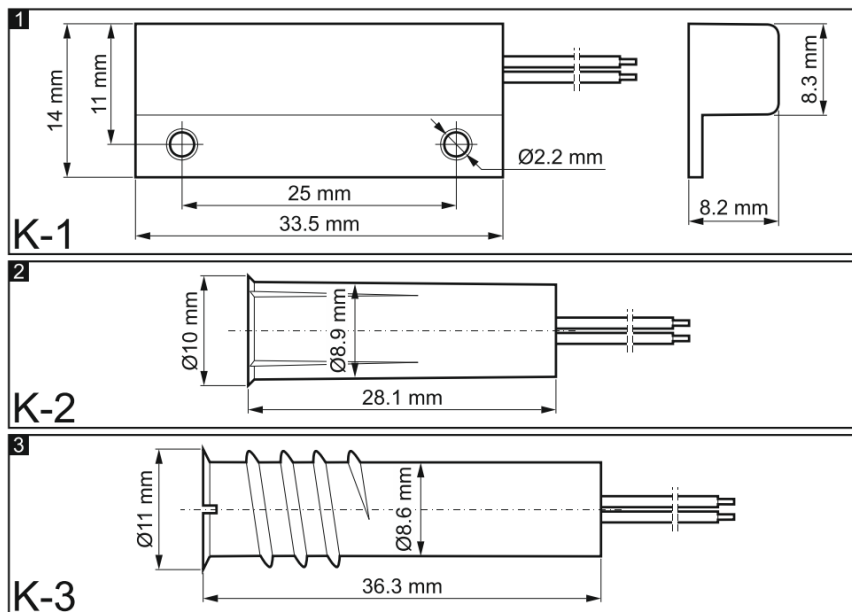

Figure 108 K-x series sensor installation dimensions.

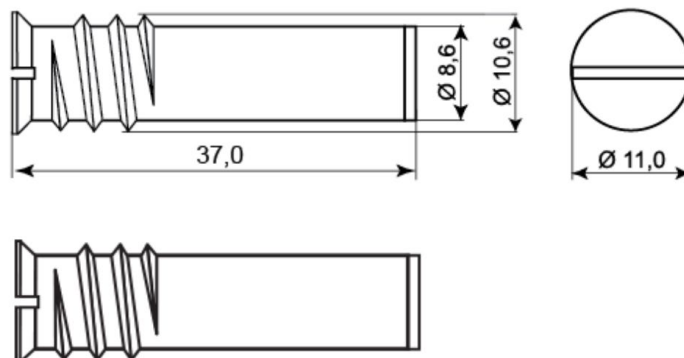
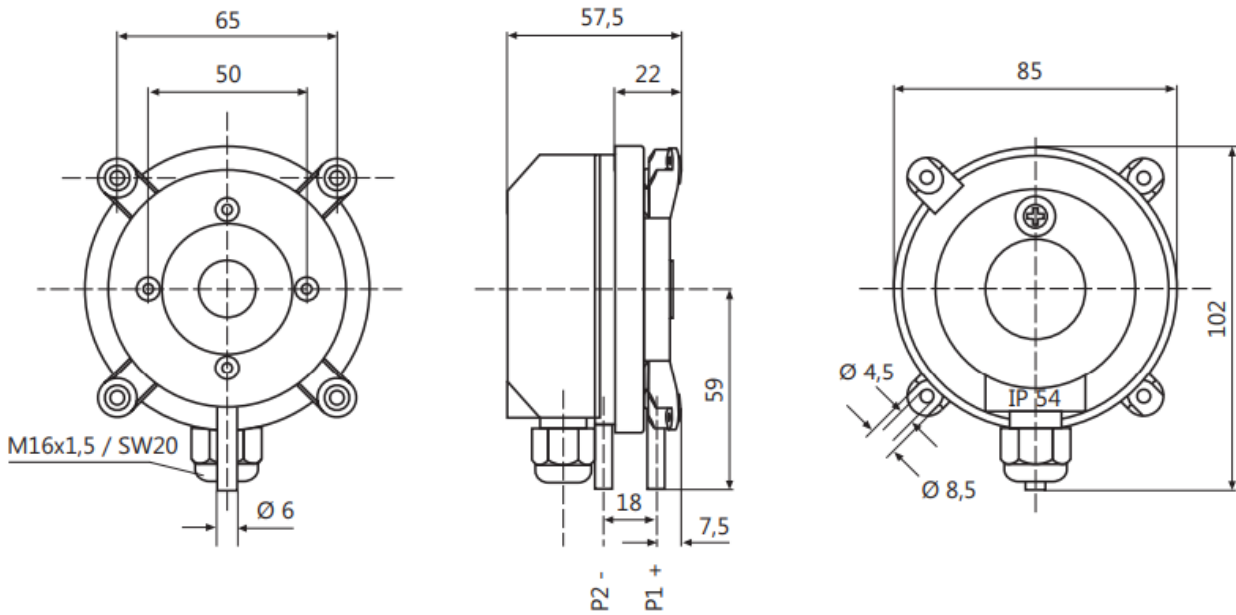

Figure 109 Installation dimensions of MC-240 series sensors.

8.9. Differential pressure switch



*Pressure input P1 (+) is connected downstream from the fan.
Pressure input P2 (-) is connected upstream from the fan.*

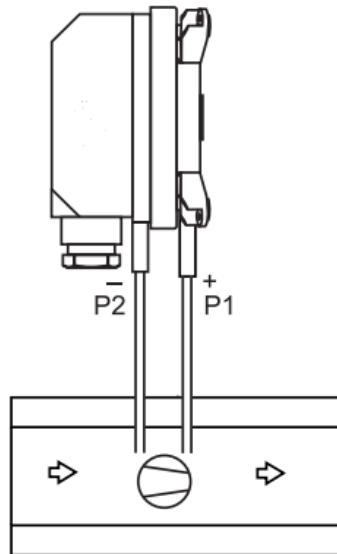

Figure 110 Installation diagram of a LF series differential pressure switch.

9. ACTIVATION OF THE MCR EXI-F SYSTEM

All devices operating in a mcr BUS loop must be marked with the same version. Detection of a device with a different version will result in the system reporting an error. The dedicated application version used for configuring the system should have the same or higher version than the devices used in the system.

The automation system is configured at 30% of the fan operation frequency (Hz) value. This allows safe initial starting of the fans in order to diagnose for potential damage, e.g. check the fan rotation direction.

9.1. mcr EXi-F application

Computer software prepared for working with mcr EXiF system equipment allows for the initial configuration and diagnostics within the following scope:

- configuration of the operating mode and parameters - including installation diagram,
- system operation preview via graphs and predictive mode adaptation,
- detected mcr ICS transmitters status preview,
- drafting a report and preview of saved data,
- access to recorded system errors history,
- access to recorded system configuration parameters changes history.

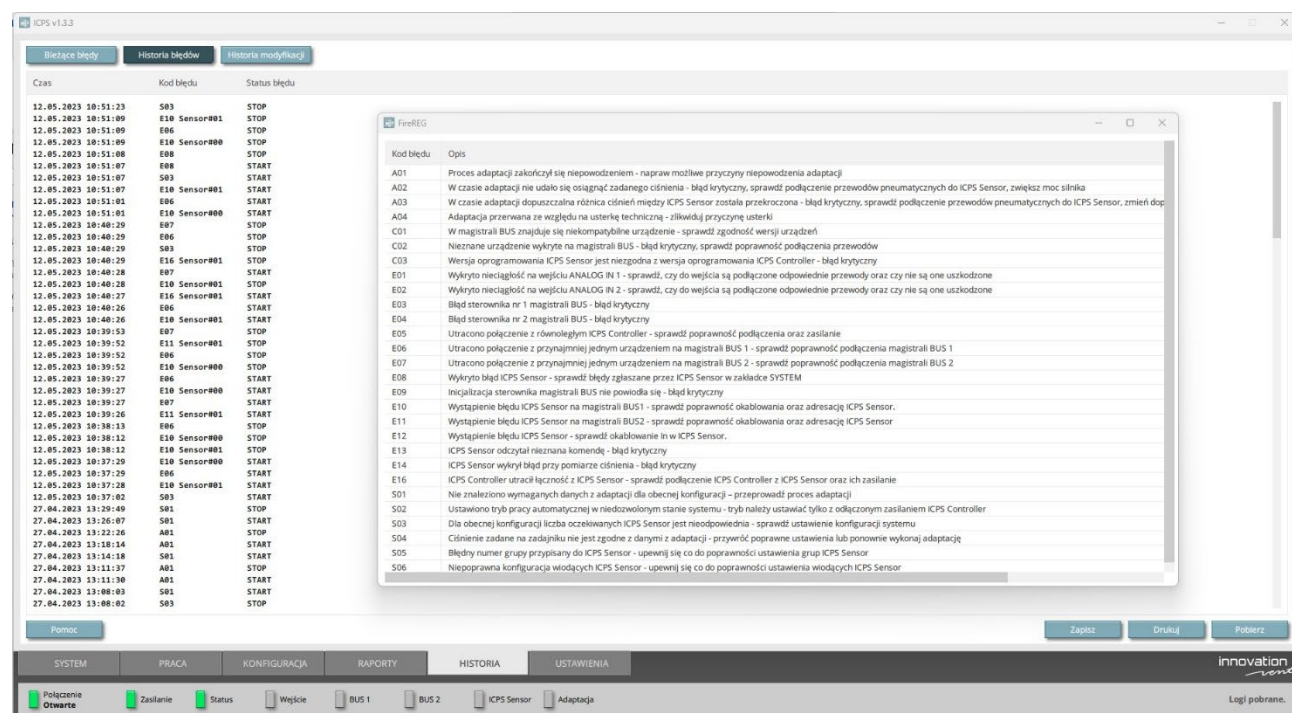
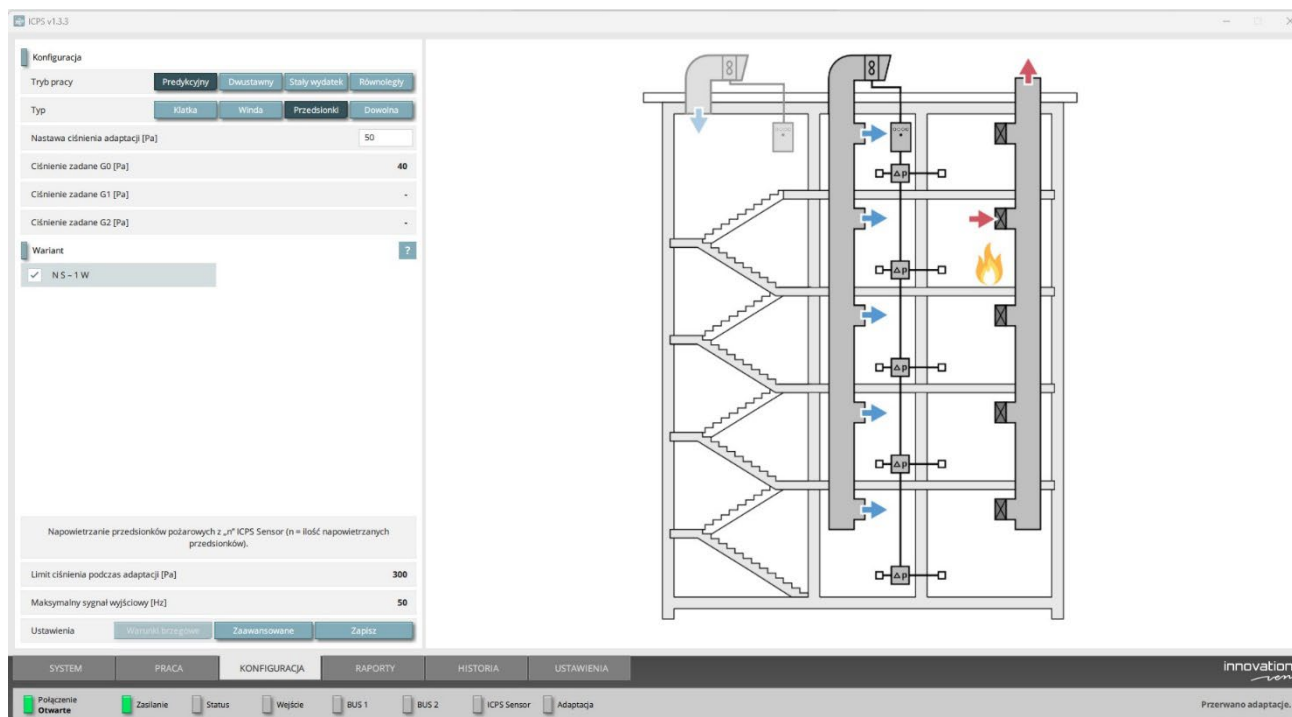

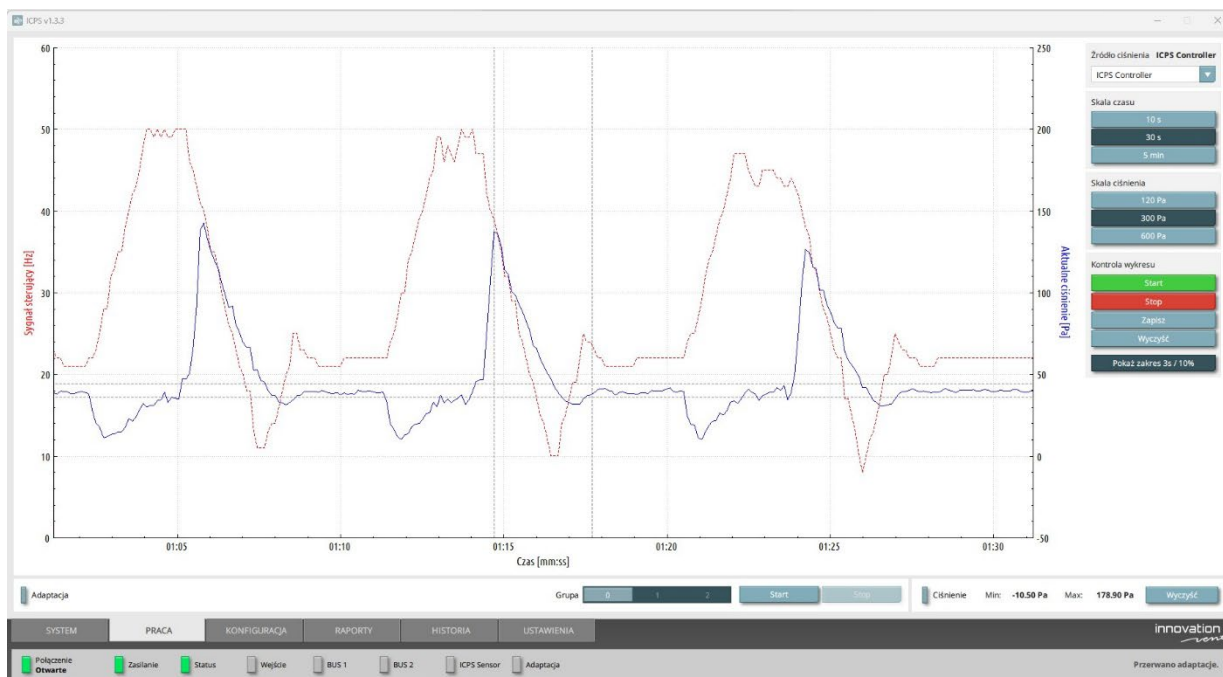

Figure 111 Sample screenshots of the mcr EXi-F application.

The software allows to monitor the system for correct operation - pressure values over time (system stabilization within 5 seconds).
 To access the application, please contact your account manager.

9.2. Commissioning, adjustments, measurements

In order for the mcr EXi-F system to operate properly, it must be commissioned according to the guidelines of Mercor S.A., which include a proper commissioning procedure, allowing for subsequent adjustment and measurements stages, which impact the stability and efficiency of the entire system, to be started seamlessly. Proper system commissioning is only possible following proper installation and connection of all the components, which is necessary for ensuring optimum efficiency of our system. Following the guidelines will allow to make maximum use of our system and will ensure long-term and reliable operation of the EXi-F system.

9.2.1. Guidelines

Prior to initiating system commissioning, adjustments and measurements, the following requirements must be met:

- All construction, installation and connection works should be performed in line with the applicable mcr EXi-F system design and the operation and maintenance manual (OMM) for the system and the individual devices.
- Commissioning of the system can only be carried out after proper installation and connection.

Adjustments and measurements, on the other hand, can only be carried out after proper commissioning. Apart from the conditions necessary for their completion, adjustment and measurements are subject to the following requirements:

- mcr EXi-F system devices must be installed in accordance with the OMM for the mcr EXi-F system
- Air distribution installations must be provided
- mcr EXi-F system devices must be connected to the air distribution system
- Air extraction installations must be provided

All shut-off dampers and fire ventilation elements must be installed and their mechanical operation must be confirmed
A pneumatic system must be provided
All the pressure measurement points must be installed and connected to the pneumatic system as per the mcr EXI-F system OMM
Power supply must be provided to all mcr EXI-F system devices (400 V AC, 230 V AC, 24 V AC)
Power supply must be provided to all devices working with the mcr EXI-F system (400 V AC, 230 V AC, 24 V AC) as per the design
All fire penetrations in the walls must be completed
The 400 V AC uninterruptible power supply system was ready to deliver voltage to the equipment
The 24 V DC uninterruptible power supply system was ready to deliver voltage to the equipment
mcr BUS system for the mcr EXI-F system must be installed
mcr BUS connections for the mcr EXI-F system must be completed
Programming has been completed according to an up-to-date and approved building fire scenario and the proper operation of the fire signaling system (FSS) has been confirmed
Connect the mcr EXI-F system devices to the FSS and confirm proper interoperation as per the mcr EXI-F system OMM
Connect the air evacuation system elements to the FSS and confirm proper interoperation
Connect shut-off dampers and fire ventilation vents to the FSS and confirm proper interoperation as per the building's fire scenario
FSS is ready to deliver a signal to the mcr EXI-F system as per the building's fire scenario
The building has an access control system that was connected to the FSS and their proper interoperation has been confirmed
Elevators have been connected to the FSS and follow an algorithm as per the building's fire scenario
A person responsible for energizing the mcr EXI-F devices and connected devices (400 V AC, 230 V AC, 24 V DC) is provided for the purposes and for the duration of the commissioning
A person responsible for connecting and energizing the mcr EXI-F devices and connected devices is provided for the purposes and for the duration of the commissioning
A person responsible for the FSS is provided for the purposes and for the duration of the commissioning

Before making adjustments and taking measurements, the following are necessary:

Complete all construction and finishing works, i.e. plasters, flooring, sealing openings, fire penetrations
Complete all installation works in staircases, i.e. doors, sealings, threshold battens, door closers, door locks, door bolts, handles

Complete adjustment of all door closers to a minimum closing force not exceeding 40 N

The following conditions should be met during adjustment and measurements:

1. No works may be carried out at the sites where adjustments and measurements are performed and no third parties may be present there, i.e. in staircases, staircase lobbies, elevator lobbies, elevator shafts.
2. Persons responsible for the connected systems must be available on site, i.e. FSS, access control system, air distribution and evacuation system, as well as the power supply system.

CAUTION!

Should the actual preparations of the facility be inconsistent with the declarations, "MERCOR" S.A. will not perform works due to the failure to provide a job site and the party reporting readiness will be charged with the costs (travel costs and employee costs) as per the service price list of "MERCOR" S.A.

9.2.2. Most common errors

This section covers the identification and effective solutions for frequent installation errors. The situations described here and the relevant guidelines should help avoid any potential difficulties during the installation of mcr EXi-F system components. The following items indicate the most common errors.

1. Proper operation of each vents in the system should be inspected and confirmed, as well as whether the vents operate in accordance with the fire scenario
2. Transmitters should be assigned proper addresses, allowing for their swift localization, which will significantly reduce the system configuration time. Addresses should be assigned according to the following scheme:
 - level " 0" - address 0, level "+1" - address 01, etc.
 - level "-1" - address 21, level "-2" - address 22, etc.

Code setter setup	No jumper or jumper on the left side	Jumper in the ADDR+10 position (right side)	
0		0	10
1		1	11
2		2	12
3		3	13
4		4	14
5		5	15
6		6	16
7		7	17
8		8	18
9		9	19
A	10		20
B	11		21
C	12		22
D	13		23
E	14	(!)	23
F	15	(!)	23



3. Connection of system components should be in line with the connection diagram available in paper format inside the mcr Omega panel. Instructions with connection diagrams for the

individual system components have been placed as stickers on the internal side of the mcr Omega control panel door.

- End-of-line resistors with a rating of 10 kΩ should be installed. mcr ICS pro control panel, duct smoke detectors, etc.

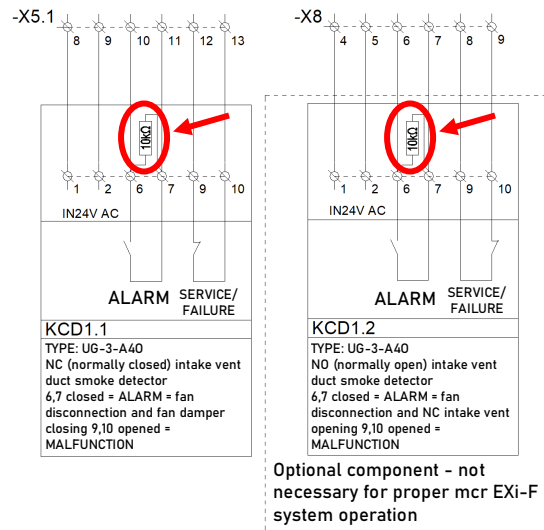
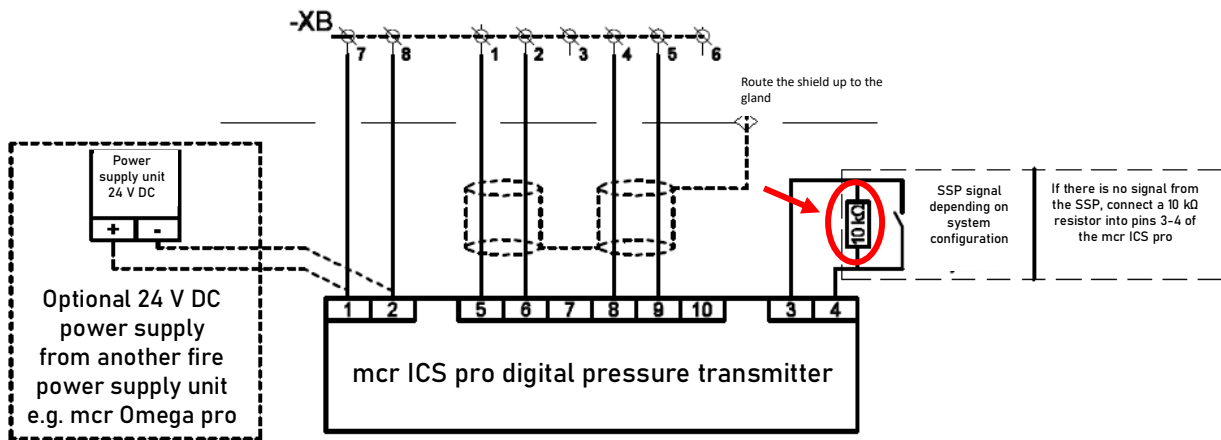

- The pneumatic system should be routed using silicone tubing with a diameter of 8 mm and a length of up to 12 m. The tubing diameter may not be reduced. Do not bend the tubing – use connection elements supplied with the tubing if changing the tubing direction. The pneumatic system may be extended, but appropriate notice must be given to „MERCOR” S.A. Below are example of incorrect and correct (using connection elements) cases of changing tubing directions.

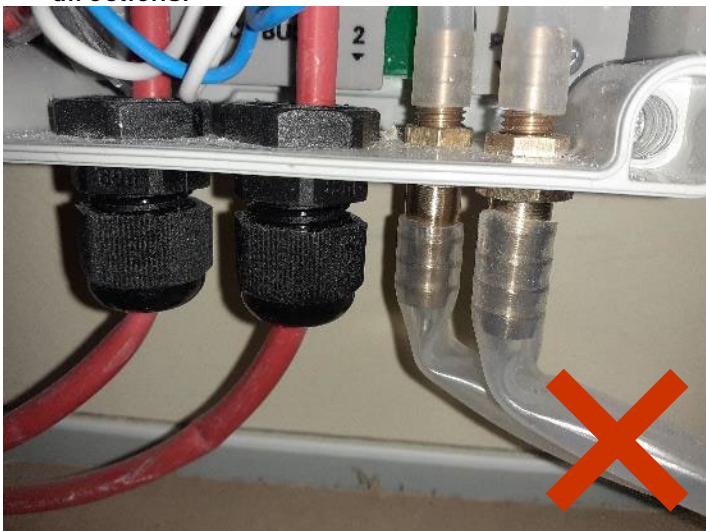

6. Pressure measuring points - reference, must be unobstructed (e.g. painting tape removed). If there are several mcr ICS Pro transmitters on a floor, check that the measuring points corresponding to the respective protected spaces (e.g. staircases, lobbies, elevators) are connected correctly. Incorrectly connected measurement points are shown below.



7. mcr ICS Pro pressure transmitters should be installed with the connection stubs of the pneumatic system facing downwards, which prevents the penetration of dust resulting from work carried out on site. The drawing below indicates the site where dust penetrates due to incorrect installation with the connection stubs facing upwards, which will eventually result in incorrect parameter readings due to the accumulation of dust.



8. Once the system components are connected and any "damage" is eliminated, inspect the proper operation of the air supply fan – direction of rotation. mcr Omega control panels delivered to the site are programmed at 30% of the air supply unit rpm regulator operating frequency, which prevents damage that may be caused e.g. by closed vents or dampers located on air supply ducts.
9. Signal and power cables (mcr Omega, air supply units) should be routed separately.



10. Do not leave batteries connected without a main power supply source for the mcr Omega control panel, as this will discharge the batteries (replacement not covered by the guarantee). Batteries should only be connected once the final power supply is connected. Batteries can be connected by "MERCOR" service during system adjustment.

10. SYSTEM ELEMENTS MARKING SCHEME

mcr EXi-F 1_2_3_ 4_5_6_7_8_9_10_11_12_13_14_15_16_17_18_19_20_21_22_23_24_25_26_27_28_29

NO.	Position	Symbol	Explanation
1	air supply unit type	100-1S	
		100-2S	
		90-1S	
		90-2S	
		80-1S	
		71-1S	
		71-2S	
		63-1S	
2	UP vertical fan	UP	mcr Monsun E1 fan in a box-type housing, with damper
3	system with backup fan	UR	second unit, with the same parameters as the basic unit
4	control and power supply automation system	S	standard version - basic unit
		R	version for a system with a basic unit and backup unit
		P	version for a vertical air supply unit - UP
		PR	version for a vertical air supply unit and backup unit
5	execution	STD	standard (painted fan, unpainted galvanized steel accessories)
		ML	painted elements (painted fan and accessories)
		SN	fan housing elements and accessories made of stainless steel
6	air supply unit fan vibration dampers	AM + pcs.	fan vibration dampers pcs.
7	air supply unit fan installation feet	Bfoot + pcs.	Big Foot installation feet pcs. ..
8	pressure transmitter pressure line	E + set	5 m pressure hose with connectors set
9	mechanical differential pressure switch	PRE	backup unit pressure switch
10	service disconnecter for air supply unit fan+	WS	service disconnecter for air supply unit installation
11	system silencer	Tp + pcs.	silencer, rectangular pcs. ..
12	shut-off damper with actuator	P	damper with Belimo actuator as standard
13	flexible system stub	KP	rectangular flexible stub on the suction side
14	flexible system stub	KP	rectangular flexible stub on the delivery side
15	shut-off damper with actuator	P	

16	inlet nozzle	DWP + pcs.	beveled rectangular duct 60o for mcr Monsun fan B0 pcs.
17	pressure transmitter	PC + pcs.	digital pressure transmitter, pcs. ... + set of 2 m cables with connectors and two pressure measuring points
18	intake vent switching system	U2	set includes two dampers with actuators
19	duct smoke detector for indoor use	C + pcs.	duct smoke detector pcs. ..
20	system manual control panel	PSR	
21	duct smoke detector for outdoor use	CW + pcs.	duct smoke detector pcs. ..
22	network separator	SEP1 +pc	SEP1 - mcr BUS
		SEP2 +pc	SEP2 - RS485
23	magnetic detector/reed	KT	
24	temperature transmitter	CT	
25	radiator	HT500 HT1000	
26	outdoor power supply cabinet	wZ	
27	automatic transfer switch	aTS	
28	network operation	KS	
29	dual ICR	2ICR + pcs.	

If a particular accessory is not available, an "X" appears in the circuit code instead of a number. If the accessory is available, the accessory designation appears in the circuit code instead of the number. Accessories are marked with the number pieces or sets. If the system also includes mcr PLD or mcr PL dampers or an mcr RPC permanent unsealing module, separate specifications should be drafted for these elements.

11. TRANSPORT AND STORAGE CONDITIONS

Each mcr ICS control panel is packaged separately. It is placed in a cardboard box and protected from damage. In case of large panels, the cardboard box is placed on a wooden pallet and attached to the pallet. An mcr Omega panel may be transported using means of transport, provided that it is secured against weather impact. For the duration of transport, the panel must be placed on its installation slab (cannot be resting on the optical indicators nor control connections). A visual inspection of the device should be carried out following each transport operation. The mcr OMEGA control panel should be stored in closed rooms, ensuring protection against atmospheric conditions. If possible, ensure that the device is isolated.

Air supply units with additional elements (duct smoke detectors, shut-off dampers) of the mcr EXi-F system are placed on pallets (for the duration of transport and storage). During loading and transportation, the packaging should not be thrown nor knocked over. Fans may be transported using means of transport, provided that it is secured against weather impact. Fans placed on means of transport should be secured against shifting during transport. A visual inspection of each device should be carried out after each transport.

Storage premises should ensure:

- no access for dust, gases, acidic fumes and other aggressive chemical vapors that have a destructive impact on insulation elements, structural elements;
- no direct exposure of vents to sunlight and UV radiation;
- maximum relative humidity not exceeding 80% at +20°C;

- ambient temperature between -20°C and +40°C;
- no vibrations.

12. MAINTENANCE AND SERVICE

„MERCOR” S.A. equipment should undergo periodical technical inspections and maintenance activities not less frequently than every 12 months during the entire period of operation, i.e. during the warranty and guarantee period, as well as thereafter. Inspections and maintenance should be performed by the manufacturer or companies authorized to service „MERCOR” S.A. equipment.

The obligation to provide regular service inspections of fire protection equipment results from the provisions of paragraph 3 section 3 of the Regulation of the Minister of Interior and Administration of June 7, 2010 on fire protection of buildings, other civil structures and areas (Journal of Laws of 2010 No. 109, item 719).

The user should perform the following during the intervals between inspections:

- Inspect the condition of electrical connections, paying particular attention to mechanical damage.
- Inspect correct supply voltage values for the equipment, with the following admissible tolerances:
 - 24 V±10% for electric actuators
 - 24 V±2% for electromagnetic release mechanisms
 - 230 V ±10% for electric actuators
 - 230 V±2% for electromagnetic release mechanisms
- Inspect the condition of the body of the equipment, paying particular attention to mechanical damage.
- Check for obstacles that could affect the proper operation of the equipment.
- Inspect the condition of seals.

In order for the service inspection and the service itself to be possible (including as part of warranty/guarantee claims), including visual inspections or repairs, the User (party ordering the inspection or repair) must ensure physical access to the equipment, for example by means of removing thermal insulation, removing suspended ceilings, removing others systems, if those prevent free access to the device etc. In case of equipment installed in ducts it is recommended to provide an inspection opening, such as the mcr KRW. If equipment is installed on the roof or at a height, a ladder or platform must be provided.

In matters related to technical inspections, maintenance and service of equipment, please contact the „MERCOR” S.A. Service Department at serwis@mercor.com.pl, tel. 058/ 341 42 45 w. 170 or fax 058/ 341 39 85 between 8 a.m. and 4 p.m. (Monday to Friday).

13. WARRANTY AND GUARANTEE CONDITIONS

1. „MERCOR” S.A. provides a 12-month quality guarantee and warranty for equipment, calculated as of the purchase date, unless stipulated otherwise in the contract.
2. A guarantee/warranty claim should be submitted to "MERCOR" S.A. within 7 days from the date when a defect covered by the guarantee (and/or warranty) becomes evident.
3. Claims can be reported via phone to 58/341-42-45, fax: 58/341-39-85, e-mail: reklamacje@mercor.com.pl or by sending a letter to: „MERCOR” S.A., ul. Grzegorza z Sanoka 2, 80-408 Gdańsk.
4. Should physical defects covered by the guarantee and/or warranty become evident during the term of the guarantee/warranty, "MERCOR" S.A. shall remove those within the shortest possible time frame, calculated from the date of receiving a written report and providing proof of purchase (contract, invoice, delivery document), subject to the provisions of item 10.
5. "MERCOR" S.A. reserves the right to extend the repair time in case of complicated repairs or those that require purchase of non-standard components or spare parts.
6. Liability under the guarantee and warranty only covers defects resulting from causes inherent to the equipment sold.

7. In case of defects resulting from improper operation of the equipment (in violation of the OMM) or from other causes mentioned under item 10, the Buyer/party authorized under the guarantee may be charged with the repair costs.
8. The condition for removing defects is for the reporting party to provide an unobstructed job site, including, but not limited to ensuring: a platform where equipment is installed at a height of more than 3 m; free access to the rooms where the equipment is installed and the necessary inspection openings; removal of thermal insulation, removal of suspended ceilings, removal of other systems, if those prevent free access to the device.
9. Where it is impossible to repair equipment at its installation site, "MERCOR" S.A. reserves the right to remove the equipment, have it delivered to the address indicated by "MERCOR" S.A. and have it reinstalled. The cost of these activities shall be the responsibility of the Buyer/party authorized under the guarantee.
10. The warranty and guarantee does not include:
 - damage and malfunctions of equipment caused by improper operation (in violation of the OMM), interference of the user or other parties not authorized by "MERCOR" S.A., failure to provide periodical technical inspections, failure to carry out the maintenance activities mentioned under the "SERVICE AND MAINTENANCE" section of this document;
 - damage caused by circumstances beyond the control of "MERCOR" S.A., including, but not limited to: fortuitous events such as: rainstorms, floods, hurricanes, flooding, lighting strikes, surges in the power grid, explosions, hail, aircraft falling down, fire, avalanches, landslides and secondary damage resulting from these events. A rainstorm shall be rain with an efficiency ratio of at least 4, as determined by the Polish IMiGW. Should it be impossible to determine the ratio mentioned in the preceding sentence, the factual circumstances and extent of damage at the place of their occurrence shall be taken into consideration, whether they indicate a rainstorm. A hurricane shall be wind with a speed of no less than 17.5 m/s (damage is considered to have been caused by a hurricane if a hurricane has been identified in the vicinity);
 - damage caused by failure to promptly report an identified defect;
 - deterioration of coatings caused by natural aging processes;
 - defects caused by the use of abrasive or aggressive cleaning agents;
 - damage caused by the action of external aggressive factors, including, but not limited to chemical and biological factors or the origin of which is related to the production processes and business operated at or in the direct vicinity of the facility where the equipment is installed;
 - parts subject to natural wear during operation (e.g. seals), unless a factory defect occurred;
 - damage caused by improper transportation, unloading, storage of the device;
 - damage caused by installation that does not comply with the provisions of the OMM and construction rules;
 - equipment or its parts that have had their nameplates or guarantee seals removed or damaged.
11. The guarantee and warranty shall expire with immediate effect in the event that:
 - the Buyer/party authorized under the guarantee and warranty introduces structural changes on their own, without agreeing this with "MERCOR" S.A. beforehand;
 - periodical technical inspections and maintenance activities have not been performed in a timely manner or have been performed by unauthorized parties or a service organization not authorized by "MERCOR" S.A. or where equipment has been operated incorrectly;
 - there has been any interference from parties not authorized by "MERCOR" S.A. - this does not include activities within the normal scope of operation of equipment.
12. The Buyer/party authorized under the guarantee and warranty shall be required to operate the equipment properly (as per the OMM) and perform periodical technical inspections and maintenance activities, as per the rules stipulated in this document under the "SERVICE AND MAINTENANCE" section.

In matters not stipulated herein, the applicable provisions of the Polish Civil Code shall apply.