

OPERATION AND MAINTENANCE MANUAL

Skylights, ventilation vents and roof hatches
mcr ULTRA THERM

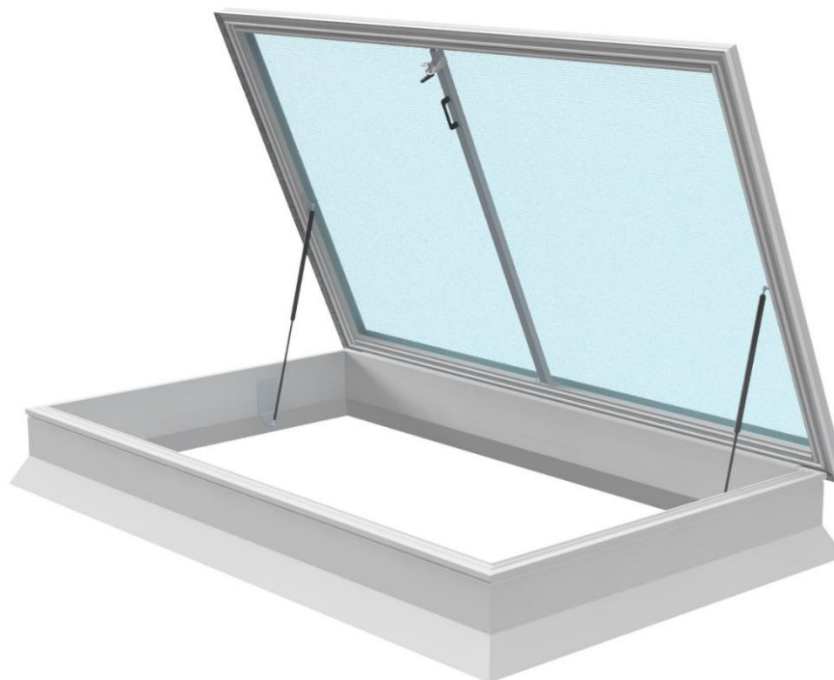
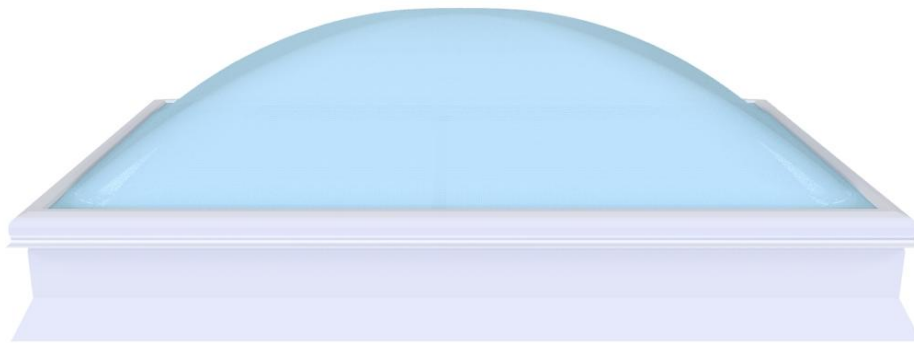

Table of Contents

- 1. INTRODUCTION 3
- 2. PURPOSE OF THE UNIT 3
- 3. CONSTRUCTION OF THE UNIT 3
 - 3.1 Construction details of fixed (non-opening) skylights 5
 - 3.2 Construction details of ventilation vents 7
 - 3.3 Construction details of roof hatches 8
- 4. TRANSPORT AND DELIVERY 10
- 5. ASSEMBLY OF THE UNIT 11
 - 5.1. Installation of the complete unit 11
 - 5.2. Assembling the unit delivered in parts 13
 - 5.2.1. Assembly of the base 13
 - 5.2.2. Installation details of a base in parts to be assembled with a PVC top flange 15
 - 5.2.3. Assembly of the fixed skylight (non-opening) 21
 - 5.2.4. Assembly of the fixed (non-opening) skylight, type FIX 23
 - 5.2.5. Assembly of the ventilation vent 25
 - 5.2.6. Assembly of the roof hatch 26
 - 5.3. Methods of the mounting the unit on the roof 29
- 6. USAGE OF THE UNIT 31
 - 6.1. Electric control 31
 - 6.2. Mechanical control 34
 - 6.3. Notes on operation 35
- 7. MAINTENANCE 35
- 8. WARRANTY AND SERVICE TERMS 35

1. INTRODUCTION

This Operation and maintenance Manual (OMM) will allow the user to learn the purpose, design, principle of operation, correct installation and maintenance of the mcr ULTRA THERM fixed and openable skylights. The documentation also contains additional information on the conditions of use, maintenance and warranty conditions of the product.

This technical and operational documentation covers:

- fixed skylights, type mcr ULTRA THERM
- ventilation vents - openable skylights, type mcr ULTRA THERM
- roof hatches - openable skylights, type mcr ULTRA THERM

Note: According to the PN-EN 1873 standard, ventilation vents and roof hatches are considered as openable skylights.

Observing the guidelines contained herein will ensure the proper functioning of systems in terms of their smoke exhausting and/or ventilation function, and the safety of system operators.

CAUTION

All work related to the assembly, operation, maintenance and servicing of skylights should be carried out in accordance with the health and safety rules and the use of appropriate personal protective equipment, including, in particular, protective equipment against falls from a height. Work related to staying at heights, connecting electrical units, etc., may only be performed by properly authorized personnel.

2. PURPOSE OF THE UNIT

The mcr ULTRA THERM skylights are units that perform the function of roof lighting, ventilation, and roof hatches. They are designed for flat and sloped roofs (up to 15°), covered with bitumen felt or PVC membrane / PVC foil.

The mcr ULTRA THERM skylights comply with the requirements of PN-EN 1873.

3. CONSTRUCTION OF THE UNIT

Depending on individual customer requirements, Mercor Light&Vent offers skylights on straight and skew bases, in a wide range of opening dimensions and base height.

Details of the construction of fixed (non-opening) skylights are presented in chapter 3.1.

Details of the construction of ventilation vents are presented in chapter 3.2.

Details of the construction of roof hatches are presented in chapter 3.3.

Basic components of skylights are:

1. Base – can come in different variants:
 - PVC base - made of extruded PVC profiles. The profiles are multi-chamber in order to obtain a low heat transfer coefficient as well as high stiffness and low weight. The height of the base ranges from 300 to 700 mm depending on the specifications of the order. The width of the base profile is 55 mm.
 - Steel base in parts to be assembled - made of galvanized sheet. Steel sheets used in ventilation vents, skylights and access roof hatches comply with the PN-EN 10346:2015-09 standard for surface type A. It can be delivered in parts

(for self-assembly) or already assembled. A top flange of base made of extruded PVC profiles is mounted on such a base. The total height of the base ranges from 200 or 300 mm to 700 mm depending on the specifications of the order. It is adapted to the installation of 50 mm thick thermal insulation.

- Welded aluminum base - made of aluminum sheet. The surfaces of the aluminum sheets used comply with the provisions of the PN-EN 485-1 standard. A top flange of base made of extruded PVC profiles is mounted on such a base. The total height of the base ranges from 200 or 300 mm to 700 mm depending on the specifications of the order. It is adapted to the installation of 50 mm thick thermal insulation.
2. Leaf - made of extruded PVC profiles. The profiles are multi-chamber for low heat transfer coefficient. To increase the stiffness, the leaf is reinforced with steel profiles. A steel profile crossbar is attached to the PVC leaf frame. The non-opening skylight leaf is equipped with segmented hinges on both sides, which are used for permanent connection with the base. In the case of openable skylights, the leaf is equipped with one long hinge.
 3. The filling is available in the following variants:
 - single or double sheet of multi-chamber (cellular) polycarbonate,
 - dome-shaped multi-chamber polycarbonate,
 - double or triple acrylic dome,
 - solid polycarbonate dome, double or triple,
 - mixed filling: multi-chamber polycarbonate sheet + dome,
 - ALU sandwich panel (aluminium – thermal insulation – aluminium).

NOTE:

Skylights with (PCA10 + PCA20) or (PCA16 + PCA16) filling or a sandwich panel can only be used on slopes $\geq 10^\circ$ or indoors (to eliminate water ponding on these flat surfaces).

4. Pressing frame – made of aluminum; available only in the FIX type skylight, which is not equipped with a PVC opening leaf. The frame is used to hold the filling – used only for multi-chamber polycarbonate sheets.
5. Opening mechanism - in the case of ventilation vents, these are electric actuators which, apart from opening and closing, also hold / lock the leaf in the closed position. On the other hand, in the case of roof hatches, the opening mechanism consists of gas springs, which support manual opening of the roof hatch. The hatch is equipped with a handle and a lock for safe and reliable locking in the closed position.

3.1 Construction details of fixed (non-opening) skylights

Fixed skylights of the mcr ULTRA THERM type are available in the following variants:

- a) with PVC base and PVC leaf → see Fig. 1, Fig. 2,
- b) with a metal base* and a PVC leaf → see Fig. 3, Fig. 4
- c) with a metal base* and a pressing frame (the FIX skylight) → see Fig. 5, Fig. 6.

* Metal base should be understood as a steel base to be assembled from parts or an aluminum welded base. It can be straight (type C, E) or skew (type NG-A).

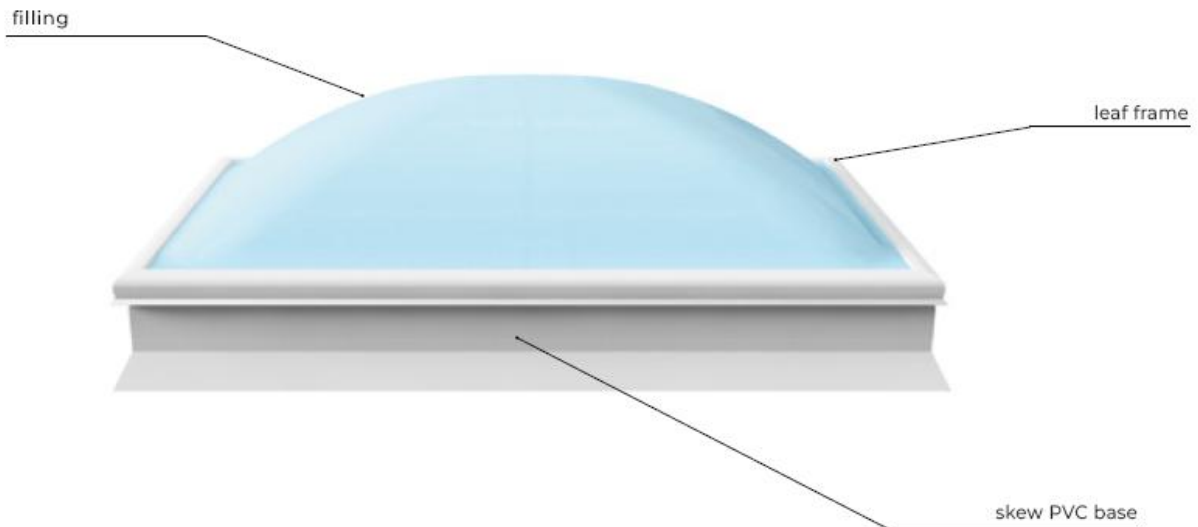

Fig. 1. Fixed skylight mcr ULTRA THERM type with skew PVC base and PVC leaf.

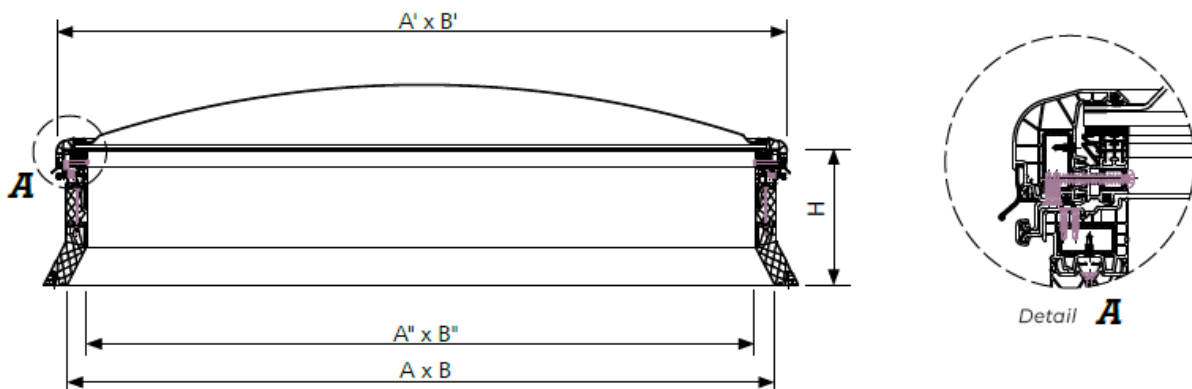

Fig. 2. Cross-section through fixed skylight of the mcr ULTRA THERM type with skew PVC base and PVC leaf.

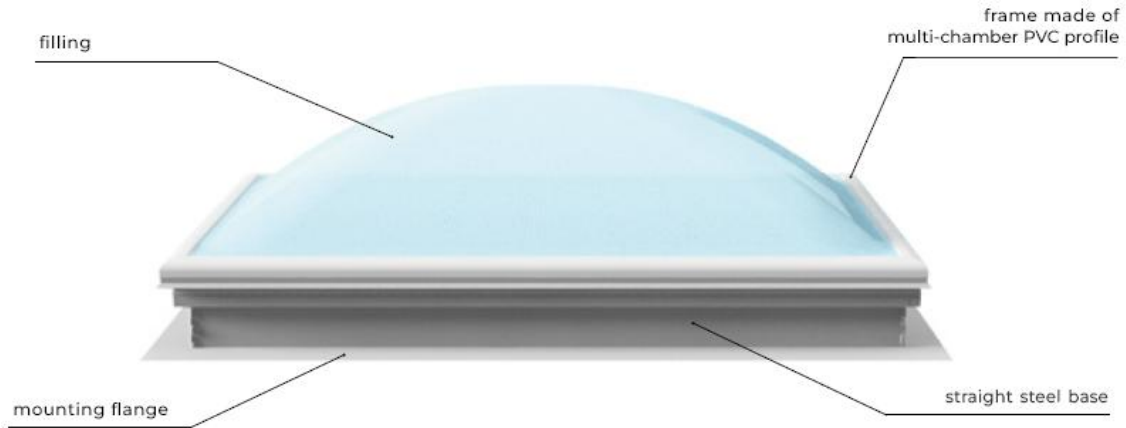

Fig. 3. Fixed skylight mcr ULTRA THERM type with straight steel base and PVC leaf.

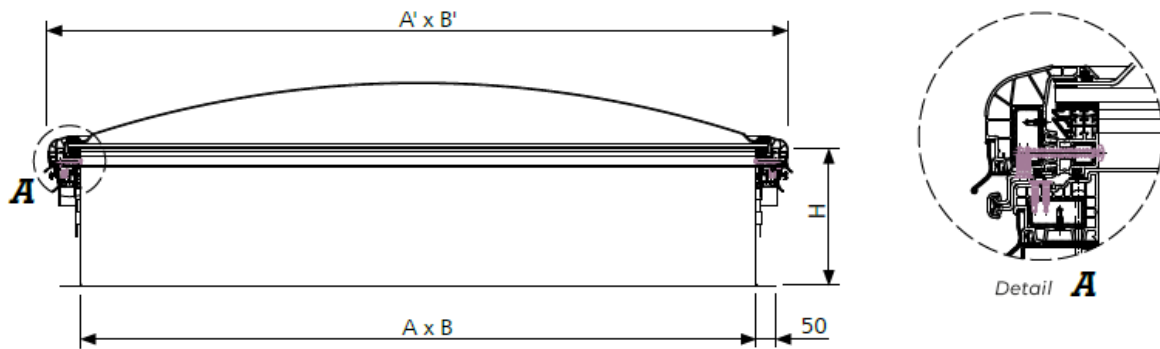

Fig. 4. Cross-section through fixed skylight of the mcr ULTRA THERM type with straight steel base and PVC leaf.

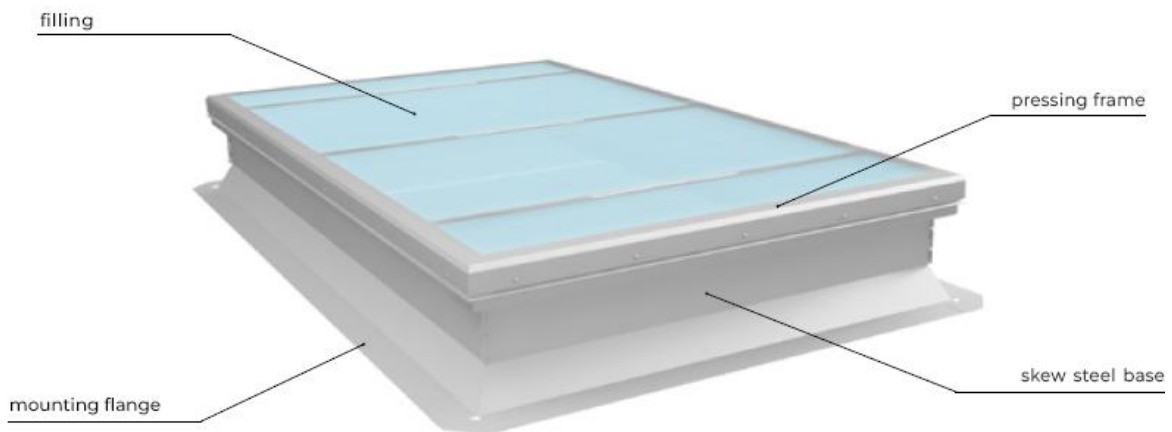

Fig. 5. Fixed skylight mcr ULTRA THERM FIX type with skew steel base and pressing frame.

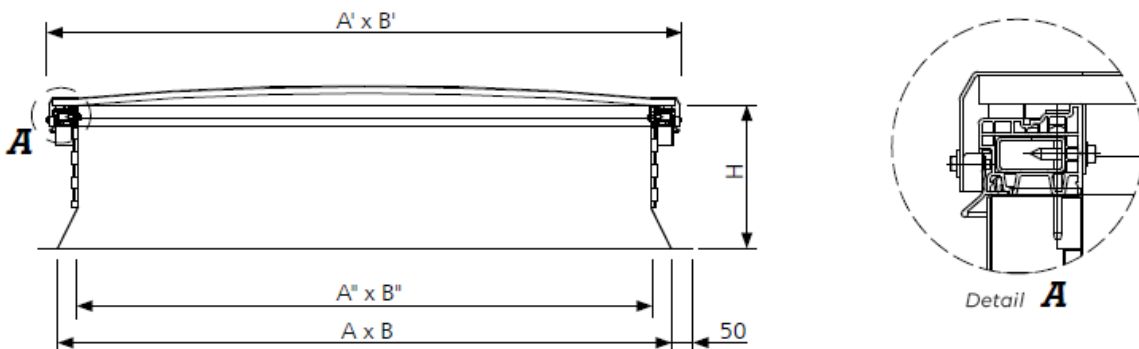

Fig. 6. Cross-section through fixed skylight of mcr ULTRA THERM FIX type with skew steel base and pressing frame.

3.2 Construction details of ventilation vents

Ventilation vents of mcr ULTRA THERM type are available in the following variants:

- a) with PVC base → see Fig. 7, Fig. 8,
- b) with metal base* → see Fig. 9, Fig. 10.

* Metal base should be understood as a steel base to be assembled from parts or an aluminum welded base. It can be straight (type C, E) or skew (type NG-A).

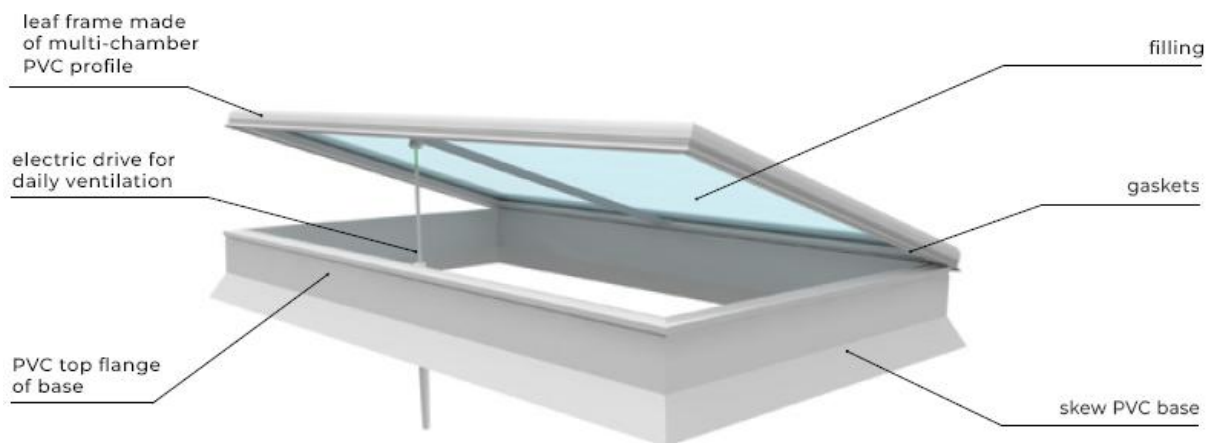

Fig. 7. Ventilation vent of mcr ULTRA THERM type with skew PVC base.

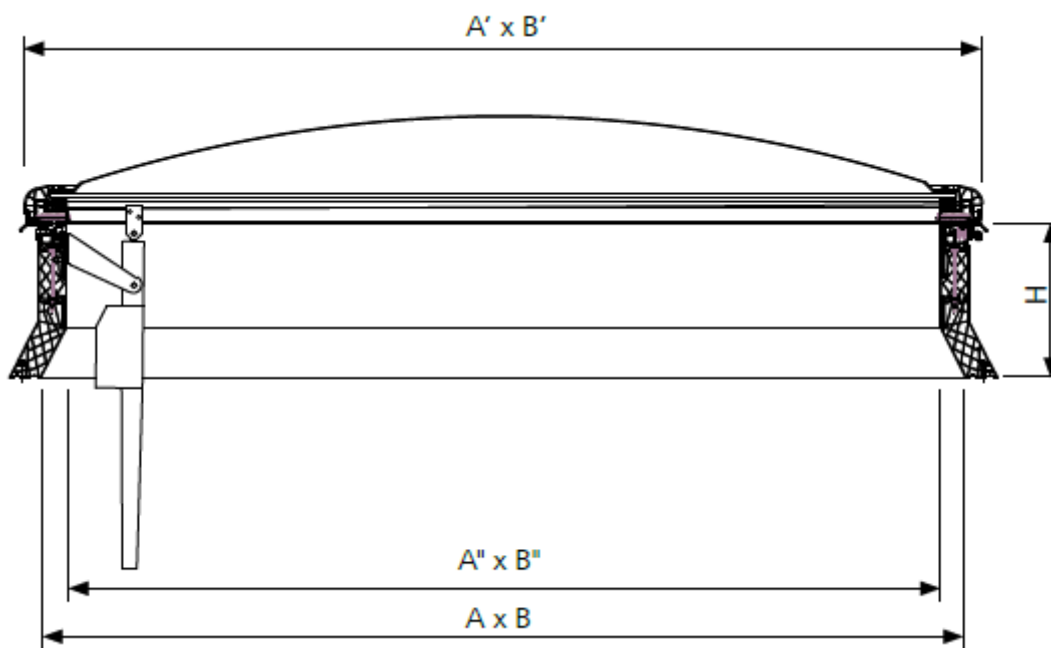

Fig. 8. Cross-section through ventilation vent of mcr ULTRA THERM type with skew PVC base.

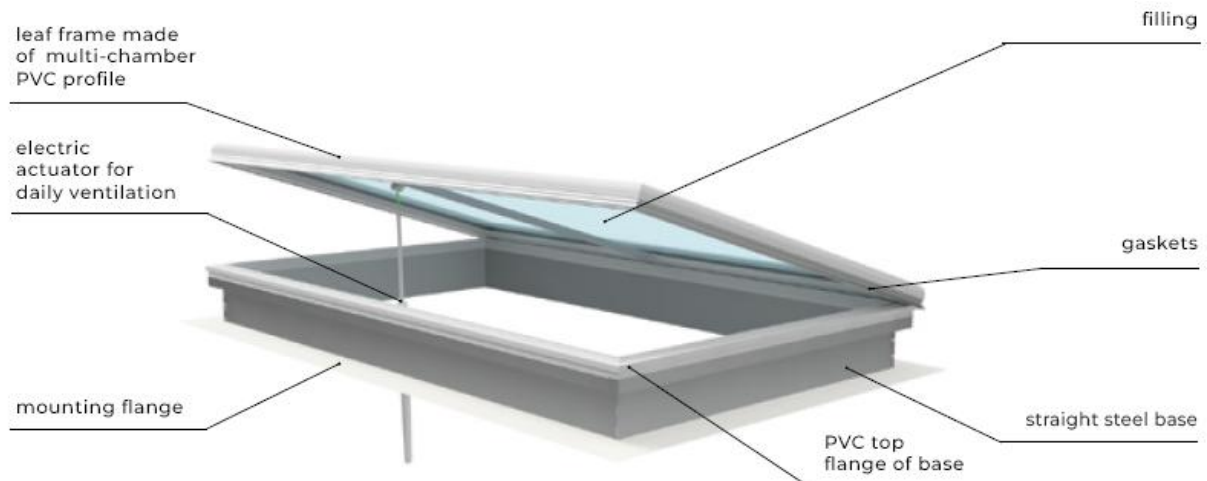

Fig. 9. Ventilation vent of mcr ULTRA THERM type with straight steel base.

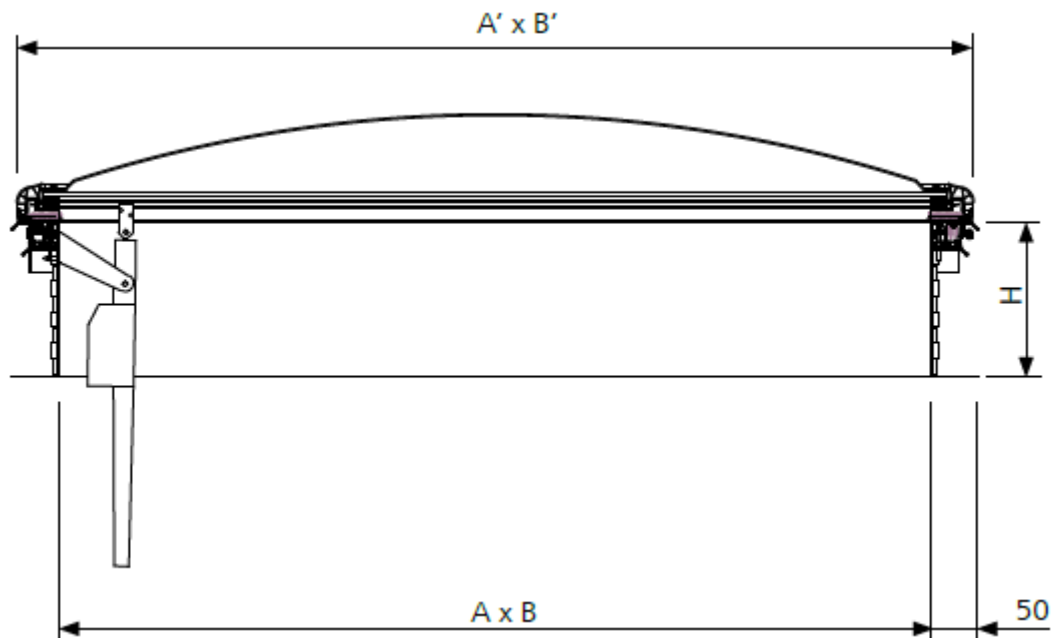

Fig. 10. Cross-section through ventilation vent of mcr ULTRA THERM type with straight steel base.

3.3 Construction details of roof hatches

Roof hatches of mcr ULTRA THERM type are available in the following variants:

- with PVC base → see Fig. 11, Fig. 13,
- with metal base* → see Fig. 13, Fig. 14.

* Metal base should be understood as a steel base to be assembled from parts or an aluminum welded base. It can be straight (type C, E) or skew (type NG-A).

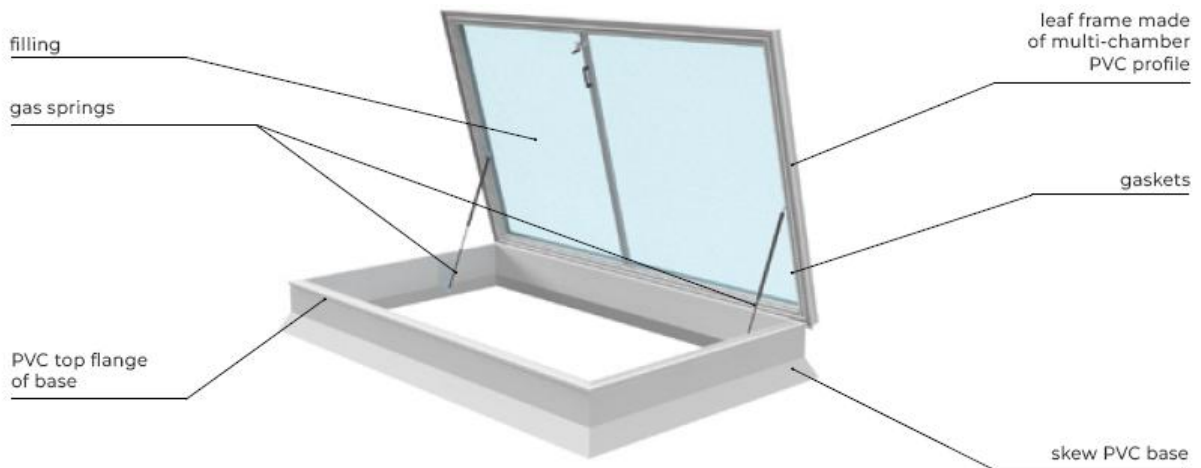

Fig. 11. Roof hatch of mcr ULTRA THERM type with skew PVC base.

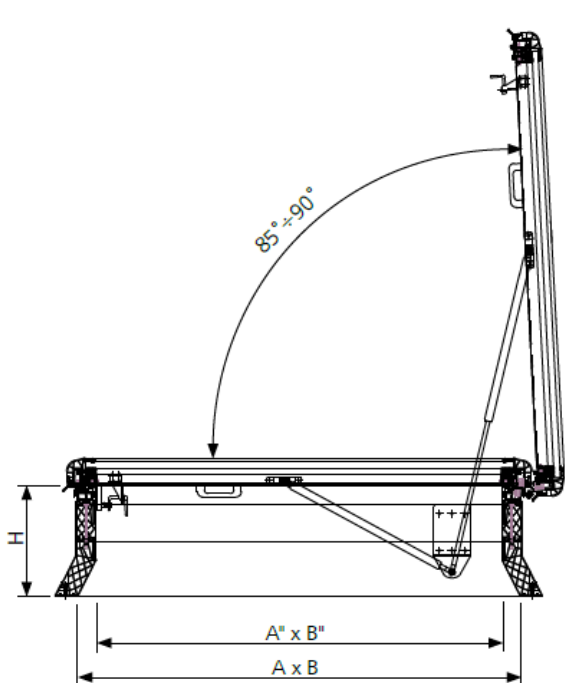

Fig. 13. Cross-section trough roof hatch of mcr ULTRA THERM type with straight steel base

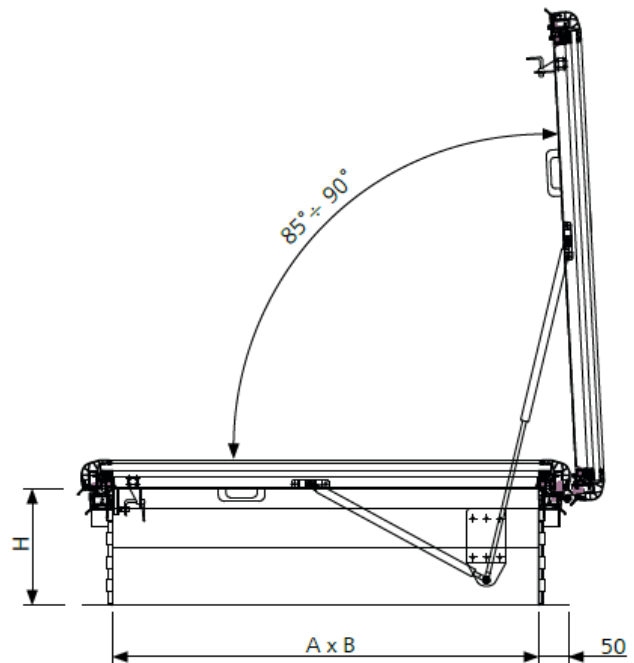

Fig. 12. Cross-section trough roof hatch of mcr ULTRA THERM type with straight steel base

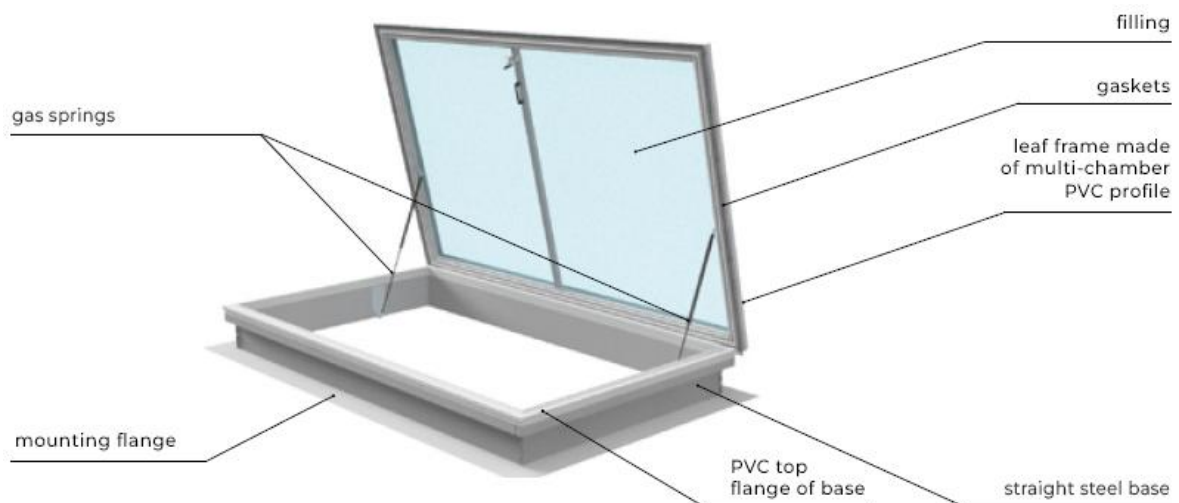

Fig. 14. Roof hatch of mcr ULTRA THERM type with straight steel base.

4. TRANSPORT AND DELIVERY

Skylights, ventilation vents and roof hatches of mcr ULTRA THERM type with PVC base can be delivered assembled (complete unit) or in parts. On the other hand, mcr ULTRA THERM units with metal base (steel base to be assembled or welded aluminum base) are always delivered in parts. The assembly is shown in chapter 5.

In the case of delivery in parts, check the completeness of the delivery according to Table 1. below.

Table 1. List of components when delivered in parts.

Base type	Non-openable skylight, type FIX (with pressing frame)	Fixed skylight	Ventilation vent	Roof hatch
PVC base	X	1) PVC base, 2) Plugs for PVC base, 3) Leaf (cover), 4) Hinge connectors, 5) grease, e.g. ŁT-43.	1) PVC base, 2) Plugs for PVC base, 3) Actuator mounting bracket, 4) self-drilling screws 6,3x19, 5) Actuator with screw connectors, 6) Leaf, 7) Hinge connectors, 8) Grease, e.g. ŁT-43.	1) PVC base, 2) Plugs for PVC base , 3) Base brackets, 4) Pin, 5) Pin console, 6) M12 nut, 7) Leaf, 8) Handle, 9) Handle with lock and a key, 10) Hook, 11) Actuator with screw connectors and washers, 12) self-drilling screws 6,3x19, 13) hinge connector, 14) Grease, e.g. ŁT-43.
Metal base*	1) Metal base*, 2) PVC top flange of base, 3) Crossbeam(s), 4) Filling, 5) Aluminum pressing frame, 6) PES gasket 40x3mm, 7) PES gasket 20x10mm, 8) Self-drilling screws 6,3x32, 9) Self-drilling screws 4,8x60, 10) Plugs for top flange of base, 11) M5 washers, 12) M5x20 screws 13) Label.	1) Metal base*, 2) PES gasket 40x3mm, 3) PVC top flange of base, 4) Screws 4,8x60 5) Plugs for top flange of base, 6) Leaf (cover), 7) Hinge connector, 7) Grease, e.g. ŁT-43, 8) Label.	1) Metal base*, 2) PES gasket 40x3mm, 3) PVC top flange of base, 4) Screws 4,8x60 5) Plugs for top flange of base, 6) Actuator mounting bracket, 7) Self-drilling screws 6,3x19, 8) Actuator with screw connectors, 9) Leaf, 10) Hinge connectors, 11) Grease, e.g. ŁT-43, 12) Label.	1) Metal base*, 2) PES gasket 40x3mm, 3) PVC top flange of base, 4) Screws 4,8x60 5) Plugs for top flange of base, 6) Base brackets, 7) Pin, 8) Pin console, 9) M12 nut, 10) Leaf, 11) Handle, 12) Handle with lock and key, 13) Hook, 14) Actuator with screw connectors and washers, 15) Self-drilling screws 6,3x19, 16) Hinge connector, 17) Grease e.g. ŁT-43, 18) Label.

* Metal base should be understood as a steel base to be assembled from parts or an aluminum welded base. It can be straight (type C, E) or skew (type NG-A).

NOTE: The hinge connectors, the opening protection connectors and the labels (quantity corresponding to that of the leaves) are packed on the same pallet as the leaves. They are attached to leaf crossbar of the top leaf.

Unloading of component parts should be carried out with the use of commonly available means of reloading appropriate for a given unit or manually, in compliance with the necessary health and safety rules.

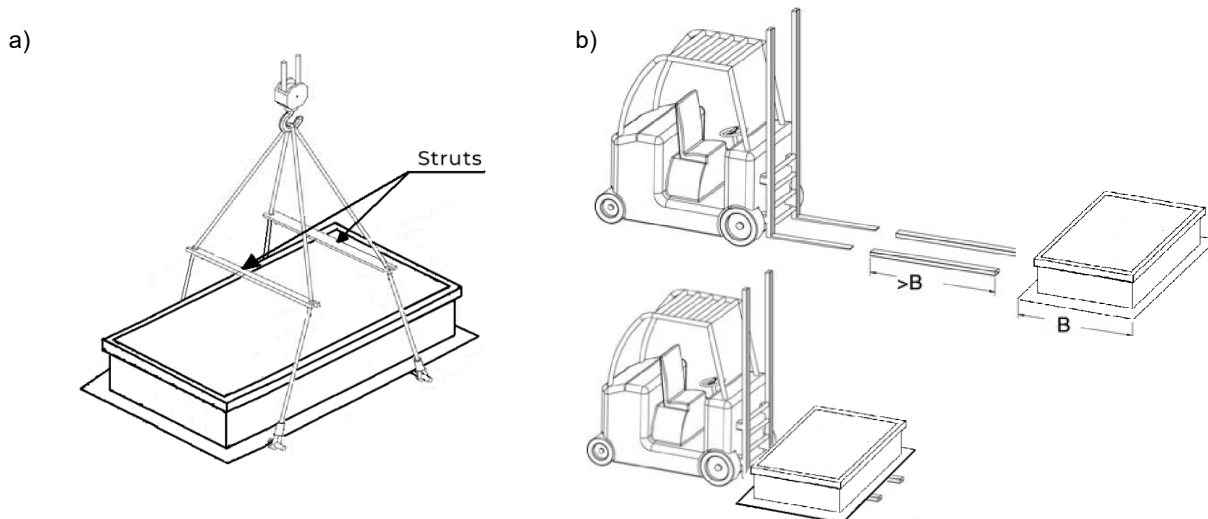

Fig. 15. Transport by crane (a) and forklift (b).

5. ASSEMBLY OF THE UNIT

The assembly should be performed in compliance with all applicable health and safety regulations, in particular those related to work at height, using appropriate personal protective equipment.

Skylights should be placed on structural elements of the roof, such as: purlins, trimmer beams, roof structural metal sheet, reinforced concrete plinth. Any elements causing a collision with the skylight leaf within its full range of motion should be removed.

The mcr ULTRA THERM skylights can be installed on roofs in a steel, concrete or wooden construction.

NOTE: the base to have continuous support along its entire perimeter.

5.1. Installation of the complete unit

Units delivered as complete units always have a PVC base. Installation of such a unit should be carried out in accordance with the description below.

- 1) Attach the base to the roof.

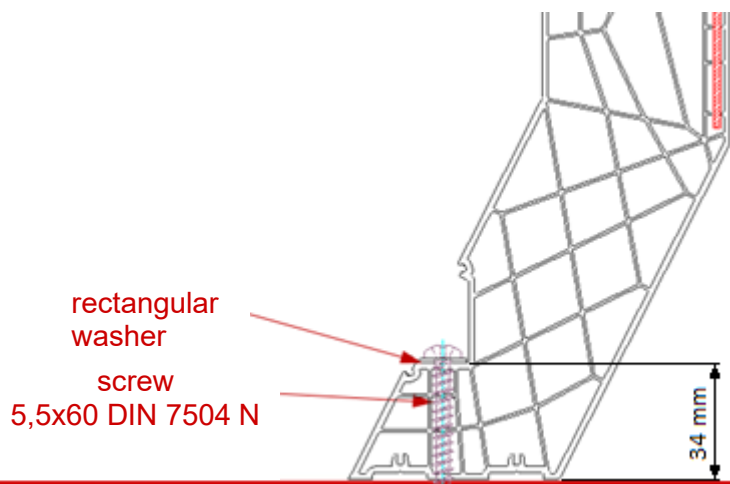

Fig. 16. Fixing the PVC base to the roof

2) Insert the lid profile in installation groove of the base.

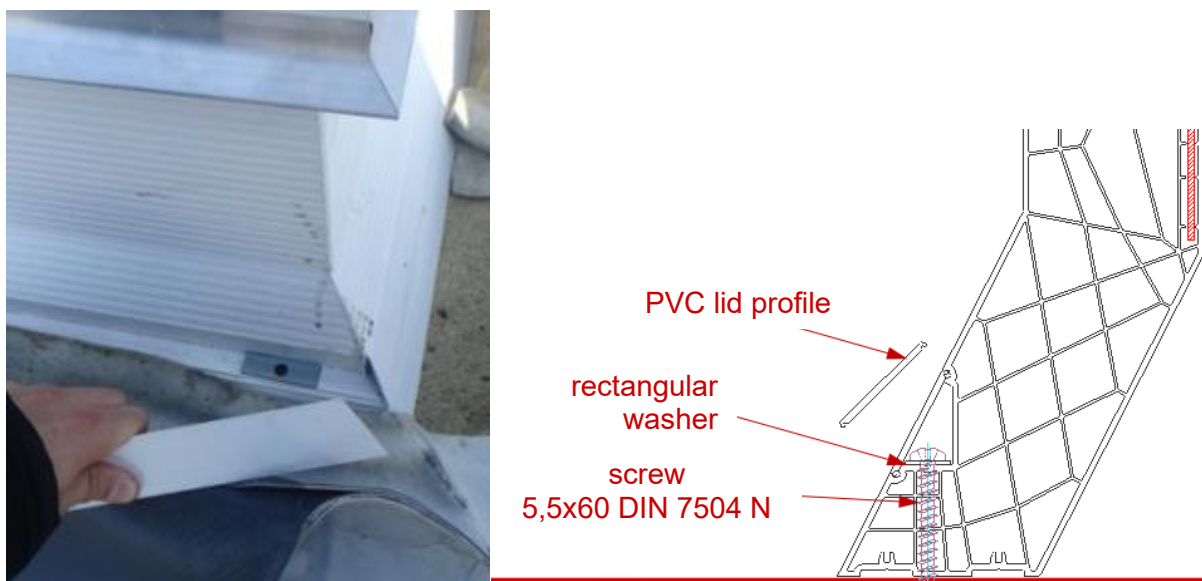

Fig. 17. Inserting the PVC lid into the installation groove.

3) Install / stick the roofing membrane.

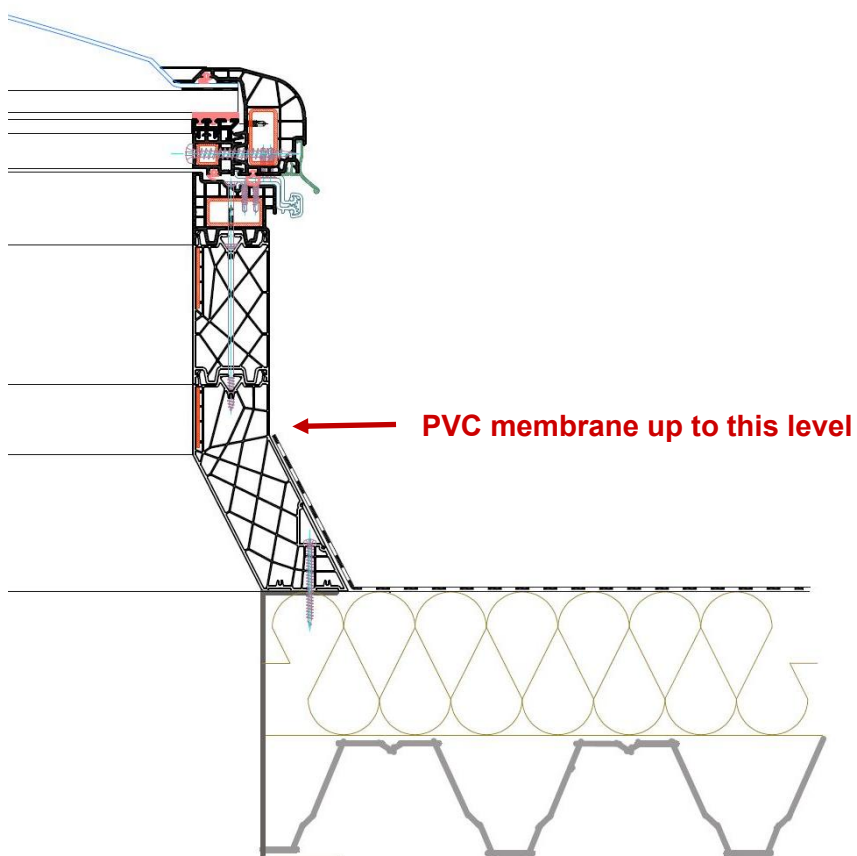

Fig. 18. Cross-section through the installed skylight / ventilation vent / roof hatch with an indication of where the roof membrane should reach.

4) Peel off the protective foil from the leaf, base and filling. Ready!



Fig. 19. Skylight / ventilation vent / roof hatch mcr ULTRA THERM after installation.

5.2. Assembling the unit delivered in parts

Units delivered in parts should be installed starting from the base - see chapters 5.2.1 and 5.2.2 - and then assembling subsequent components as described in the following chapters.

5.2.1. Assembly of the base

The base of the unit has a groove (shelf) in its lower part, which facilitates fastening to the supporting structure. For the PVC base, use only as many fasteners as there are mounting holes in this shelf. **Fasteners for attaching the PVC base are provided by the manufacturer (included in the delivery).** For a metal base, use connectors at a maximum spacing of 500 mm - with at least 3 connectors on one side of the base. Use ball or round head screws / bolts with a diameter according to the table below. **The manufacturer does not supply connectors for attaching metal bases!**

Table 2. Selection of fasteners for attaching the hatch base to the roof structure.

type of supporting structure	min. diameter of the fastener
steel	min. Ø5,5 mm
concrete	min. Ø6 mm
wood	min. Ø6 mm

For a base made of PVC profiles, a special 14x30 mm washer, supplied by the manufacturer, should be used under each screw head. The washer should be placed with its long side parallel to the edge of the base (see Fig. 16).

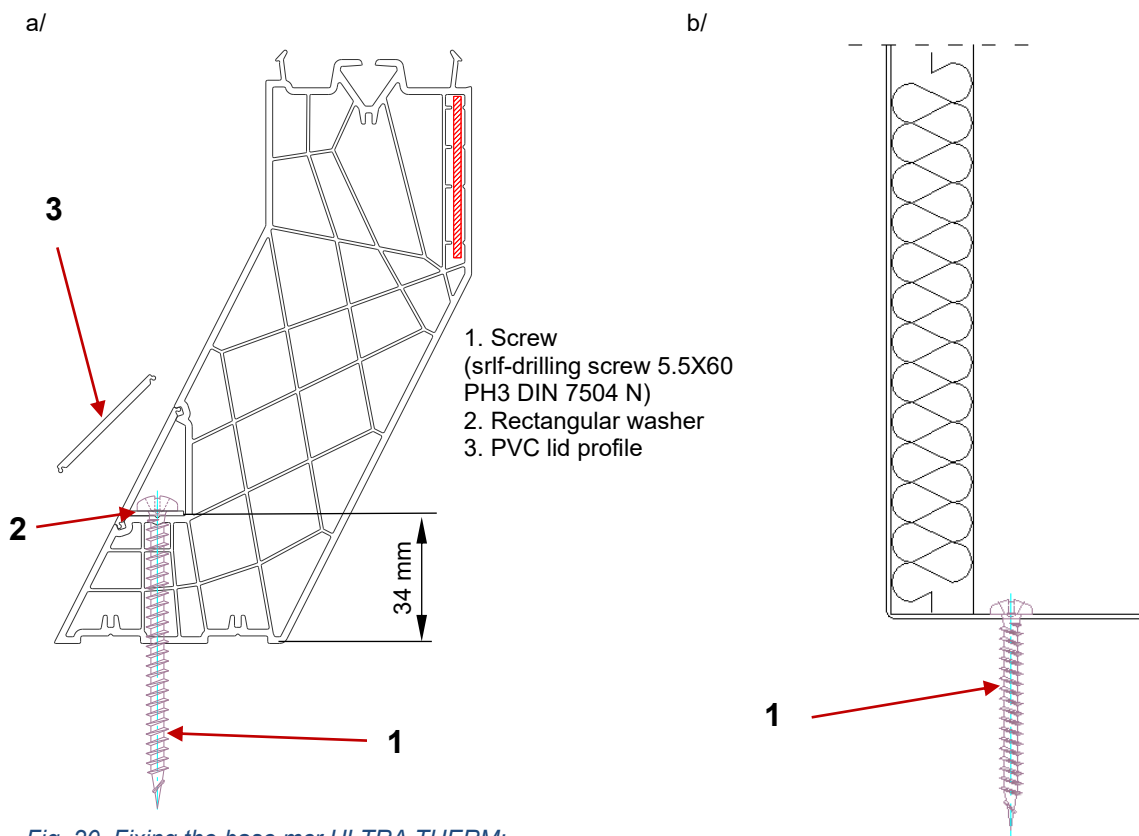

Fig. 20. Fixing the base mcr ULTRA THERM:
 a) PVC base,
 b) metal base (steel base to be assembled or welded aluminum base).

Mcr ULTRA THERM bases are suitable for roof flashings with a PVC membrane. For metal bases, before the treatment with PVC membrane, apply a thermal insulation with a thickness of 50 mm to the base. The height of the membrane flashing is shown in the figure below.

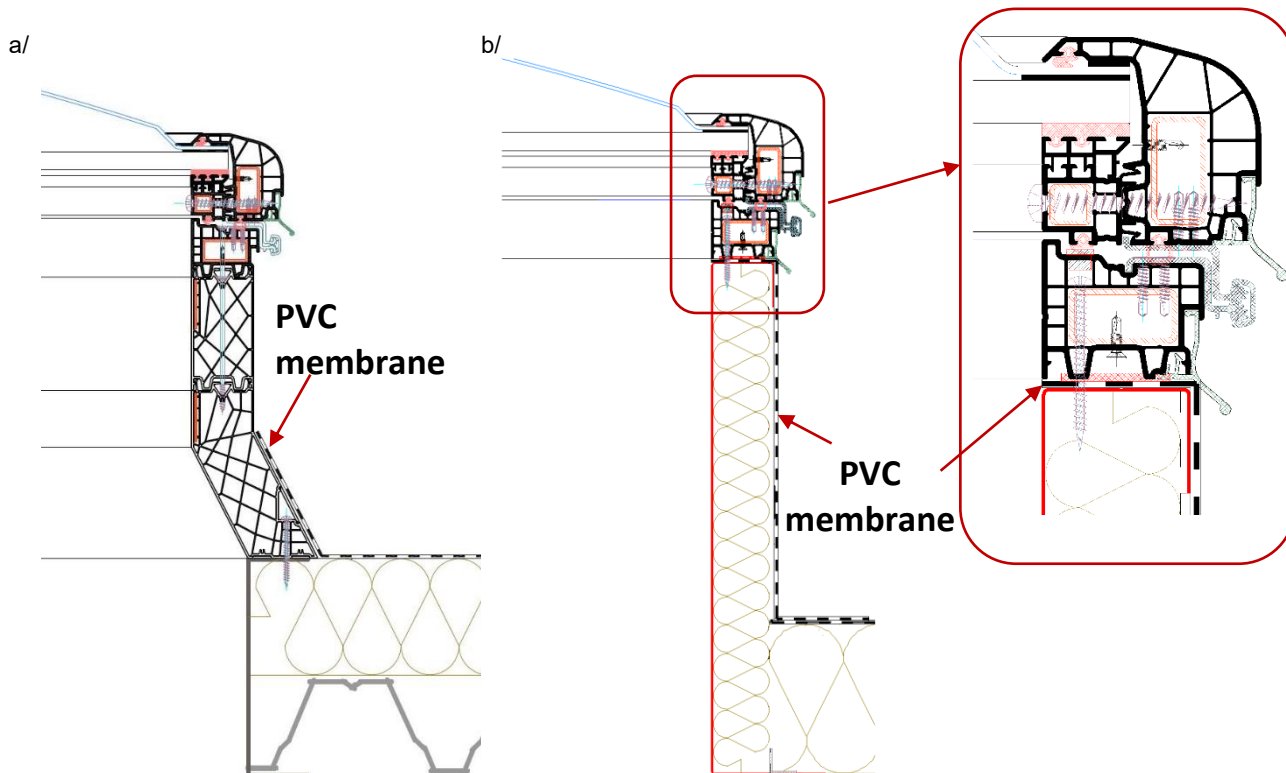

Fig. 21. The height of the membrane flashing on a PVC base (a) and on a steel / aluminum base (b).

5.2.2. Installation details of a base in parts to be assembled with a PVC top flange

Note the difference between base intended for fixed skylights and ventilation vents (Fig. 22) and bases intended for access roofs (Fig. 23).

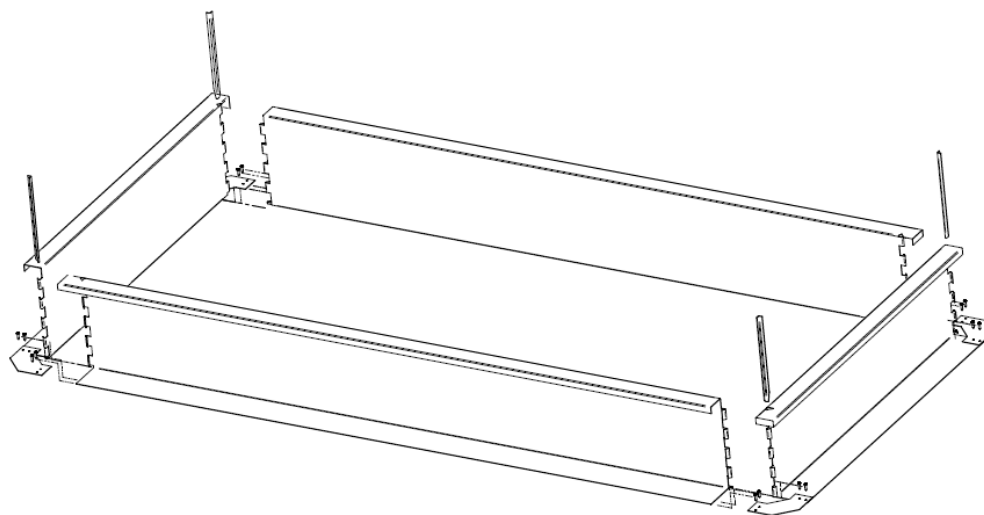

Fig. 22. Base delivered in parts intended for fixed skylight and ventilation vent.

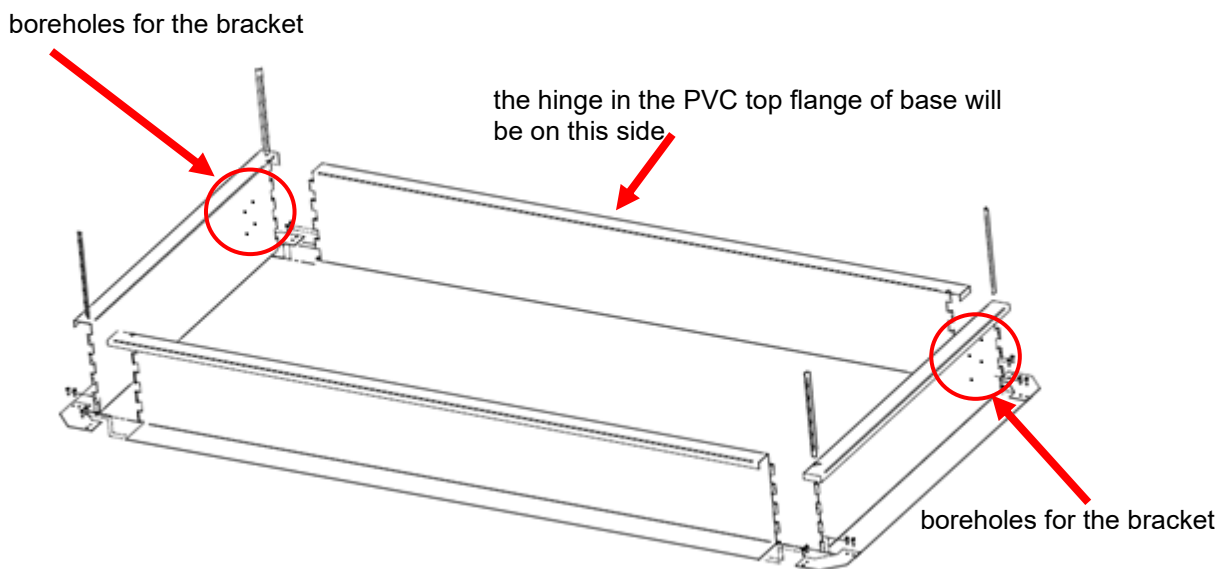

Fig. 23. Base delivered in parts intended for roof hatch.

Installation steps to be carried out in sequence according to the following instructions.

A) Assembling the base from parts.

1) Putting together the walls parts.

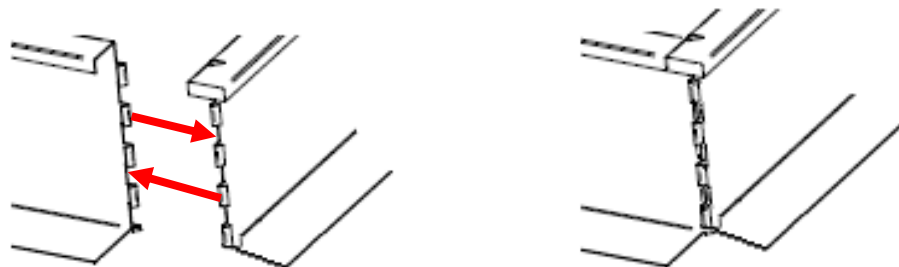

Fig. 24. Putting together the walls of the base.



Fig. 25. Properly connected walls.

2) Connecting the corners.

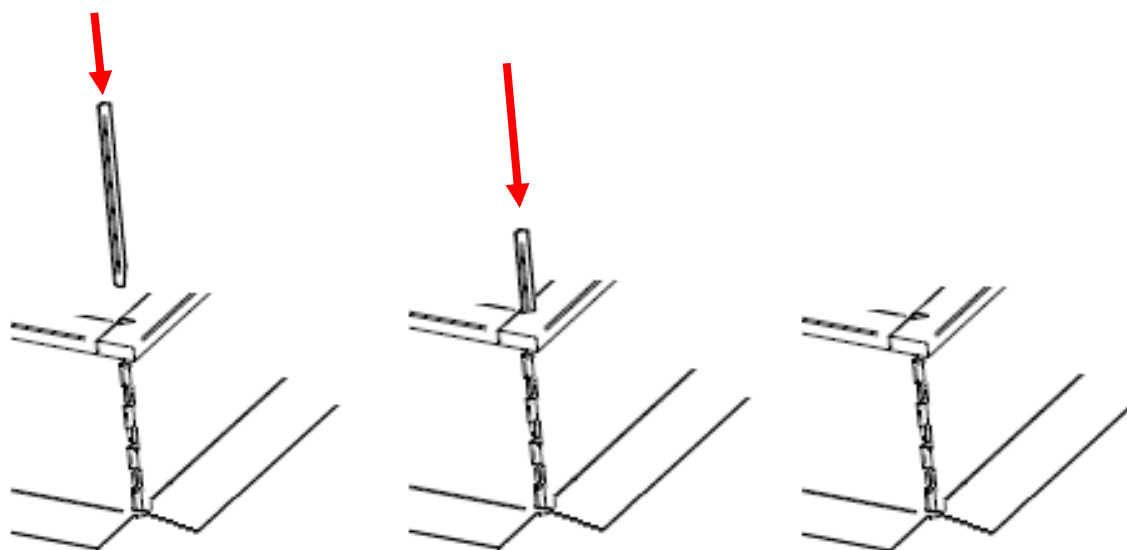

Fig. 26. Inserting the connector.

3) Screwing the corners together (using self-drilling screws 4,2x13).

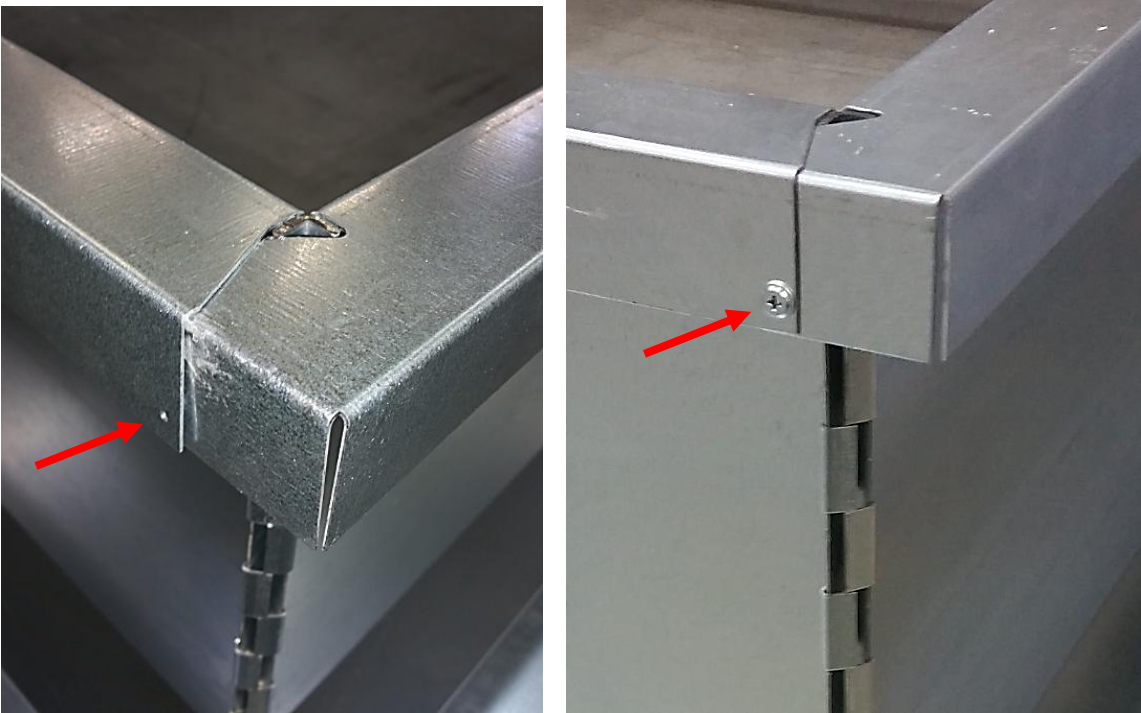

Fig. 27. Place of screwing with a self-drilling screw 4.2x13 in the corner of the base.

4) Installation of the bottom corner (optional).

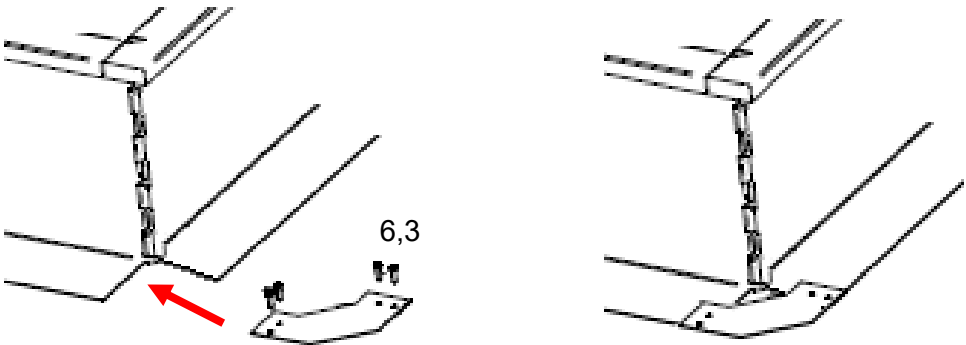

Fig. 28. Optional bottom corner.

B) Fixing the base to the roof and insulation.

- 1) Check the diagonals and correct if necessary so that both diagonals are the same.



Fig. 29. Checking diagonals.

- 2) Fixing the base to the roof.
(screws adapted to the roof structure: $\text{Ø}5,5$ or $6,3$ mm every 500 ± 75 mm)

NOTE: the base must be supported on all sides all around.

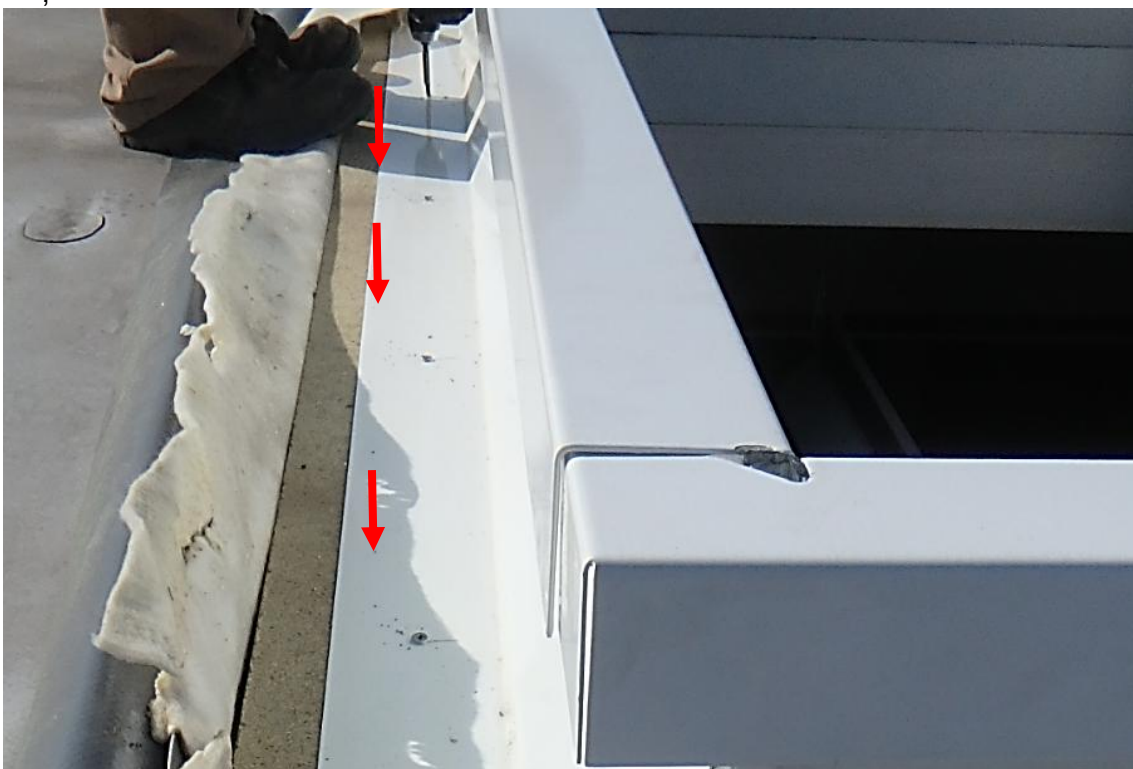

Fig. 30. Connecting the base to the roof with screws.

3) Placing the insulation.



Fig. 31. Insulated base (insulation thickness 50 mm).

4) Flashing with roof membrane.



Fig. 32. The membrane is rolled up on the base and fixed with screws. Note the location of the screws.

5) Installing the gasket PES 40x3.



Fig. 33. Attached gasket PES 40x3. Pay attention to the butt joint of the gasket in the corner.

6) Mounting the PVC top flange of base.



Fig. 34. Putting PVC top flange of base on the PES gasket.

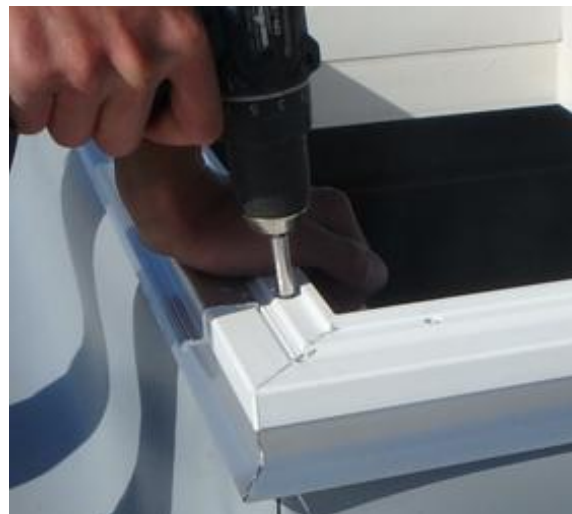

Fig. 35. Screwing the PVC top flange of base to the metal base.

NOTE: Use only as many screws as there are prepared holes in the top flange of base. The remaining surfaces of the top flange of base are to be intact.

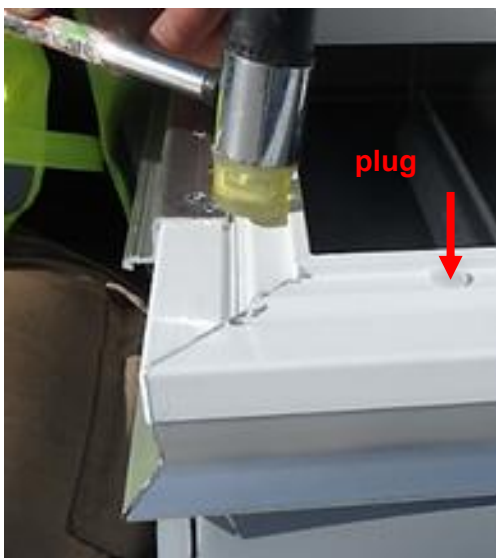

Fig. 36. Inserting the plugs in the holes of the top flange of base.

5.2.3. Assembly of the fixed skylight (non-opening)

The first stage of assembly of a fixed skylight delivered in parts is the assembly of the base (see chapters 5.2.1. and 5.2.2.). Then install the leaf and peel off the protective films. Apply the label on the hinge side near one of the corners.

Place the leaf and adjust it on the PVC top flange of base, making sure that both parts of the hinge are correctly aligned to each other (the correct positioning of the hinge is shown in the drawing below). Such a hinge is located on both sides of the leaf and the base and is used to permanently connect these parts of the skylight together.

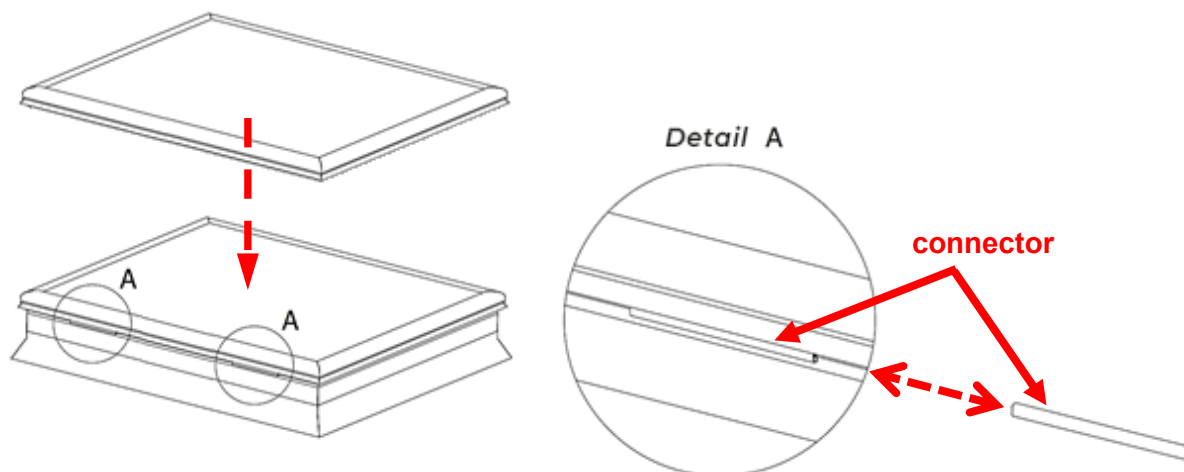

Fig. 37. Mounting the leaf in the fixed skylight.

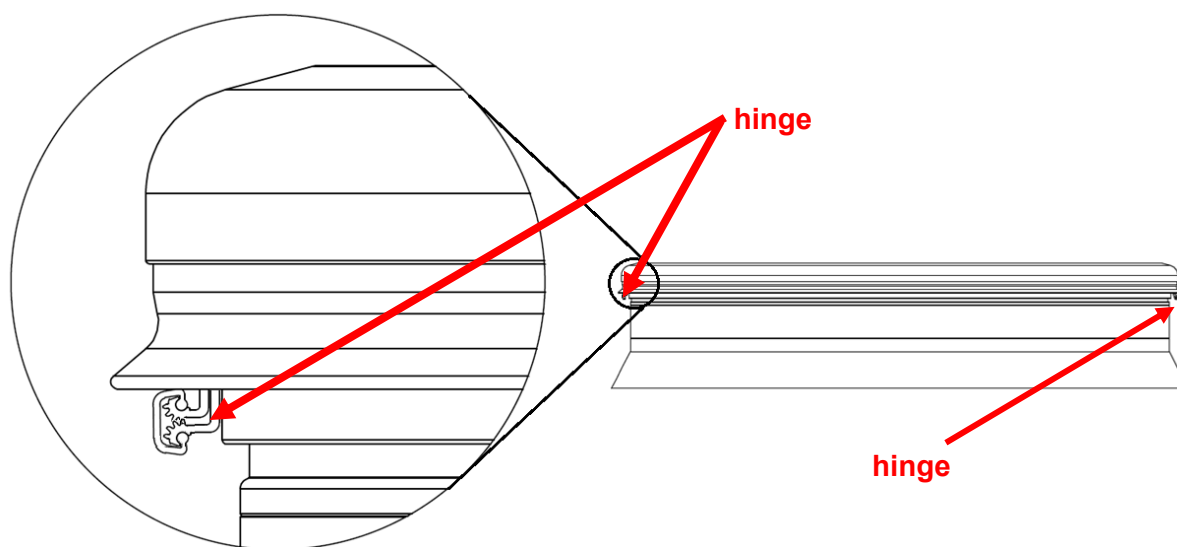

Fig. 38. Skylight with the detail of the hinge connection.

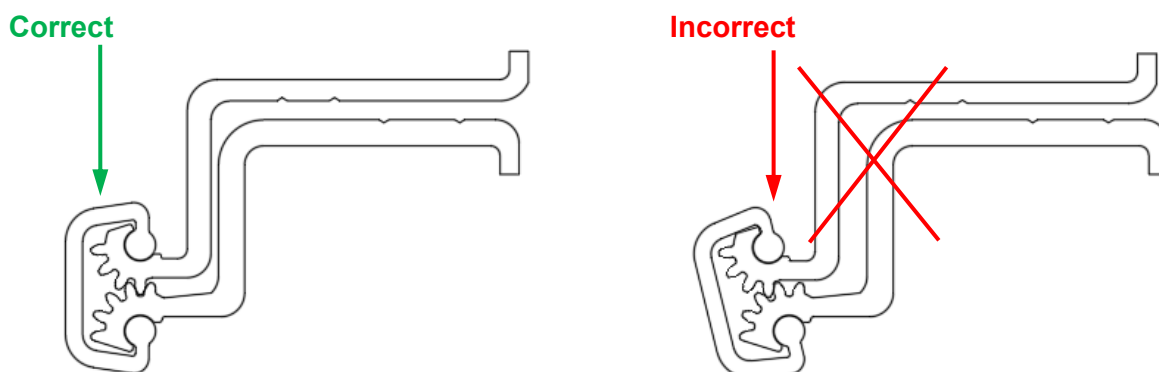

Fig. 39. Positioning the hinge.

In order to facilitate the assembly of the connector, all parts of the hinge should be lubricated with grease (LT-43 included in the delivery). Then slide the connector on as shown in the pictures below. It is recommended to hammer it through a wooden strip or with a soft mallet.

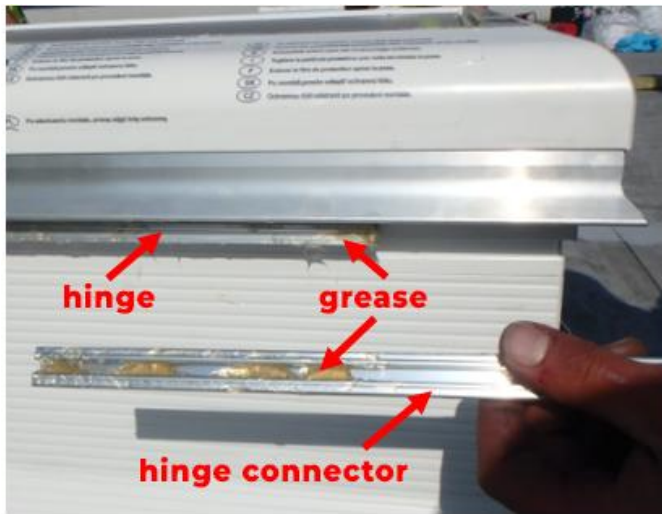

Fig. 40. Lubricating the hinge.



Fig. 41. Sliding the connector on.



Fig. 42. Hammering the connector.



Fig. 43. Hinge connection mounted.

5.2.4. Assembly of the fixed (non-opening) skylight, type FIX

The first step in the assembly of the FIX fixed skylight is the assembly of the steel base consisting of parts (see chapter 5.2.2.).

In the case of FIX skylights, the method of delivery is such that the PVC top flange of base has crossbeams mounted and is screwed with the pressing frame under which the filling is located. To screw the top flange of base to the base, first disassemble the entire unit as shown in the figure below. Remove the protective films. Do not lose the sheet metal screws and washers.

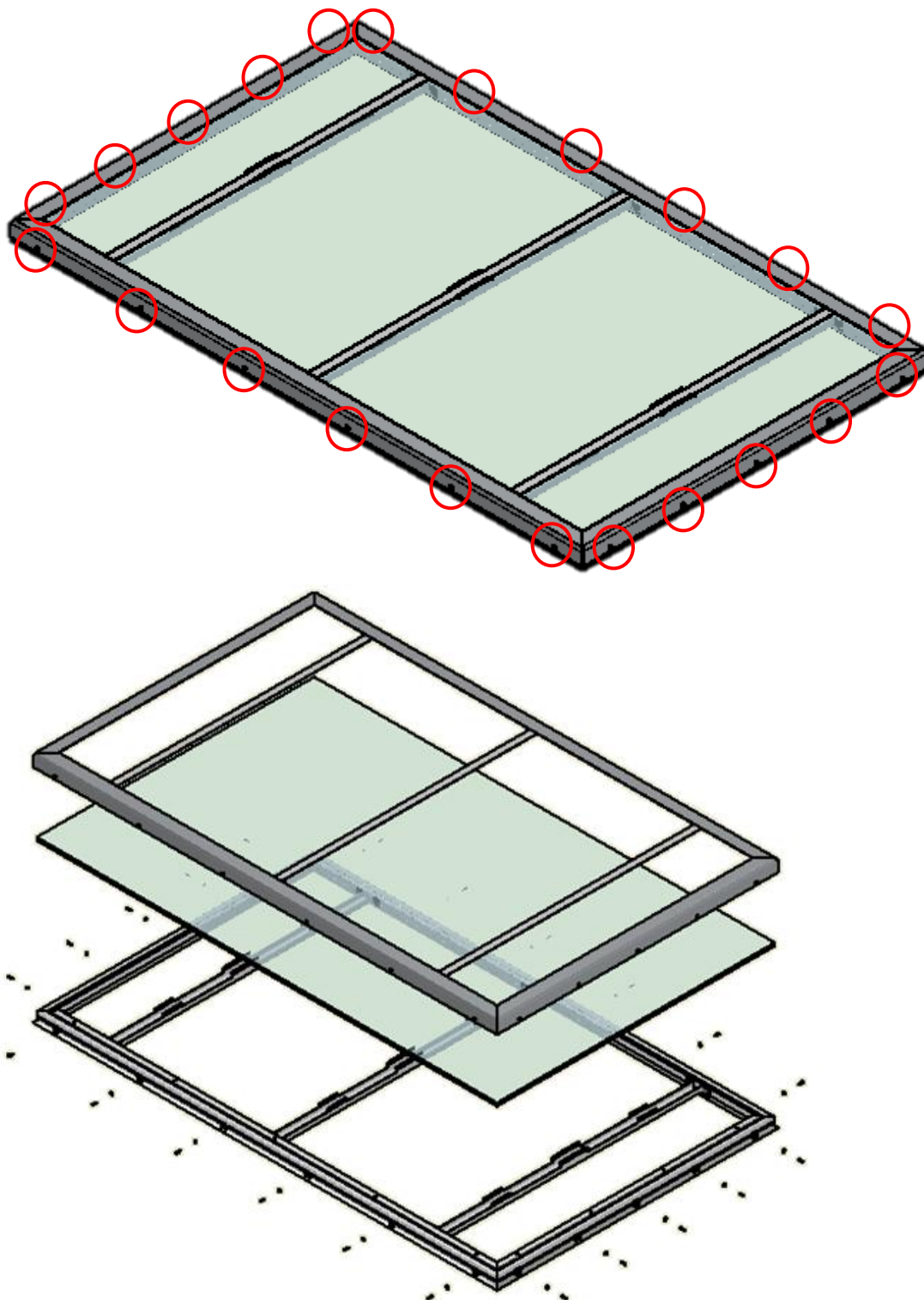

Fig. 44. Unscrewing the pressing frame from the top flange of base (M5 screw connection marked with a red circle in the drawing).

The PVC top flange of base must be installed as described in chapter 5.2.2. Then the PES 20x10 gasket should be glued, if it is not fitted at the factory.



Fig. 45. Base of the FIX skylight with installed PVC top flange of base equipped with crossbeams and a PES 20x10 gasket

Apply the label on the skylights' side near one of the corners. Install the filling as it was positioned in the same way as in the delivered unit before unscrewing. Install the pressing frame, fasten with sheet metal screws $\text{Ø}4.8 \times 13$ PH (ISO 7049) A2 with washers.

NOTE: Tightening torque for sheet metal screws 2.5...3.3 Nm. DO NOT EXCEED THESE VALUES!

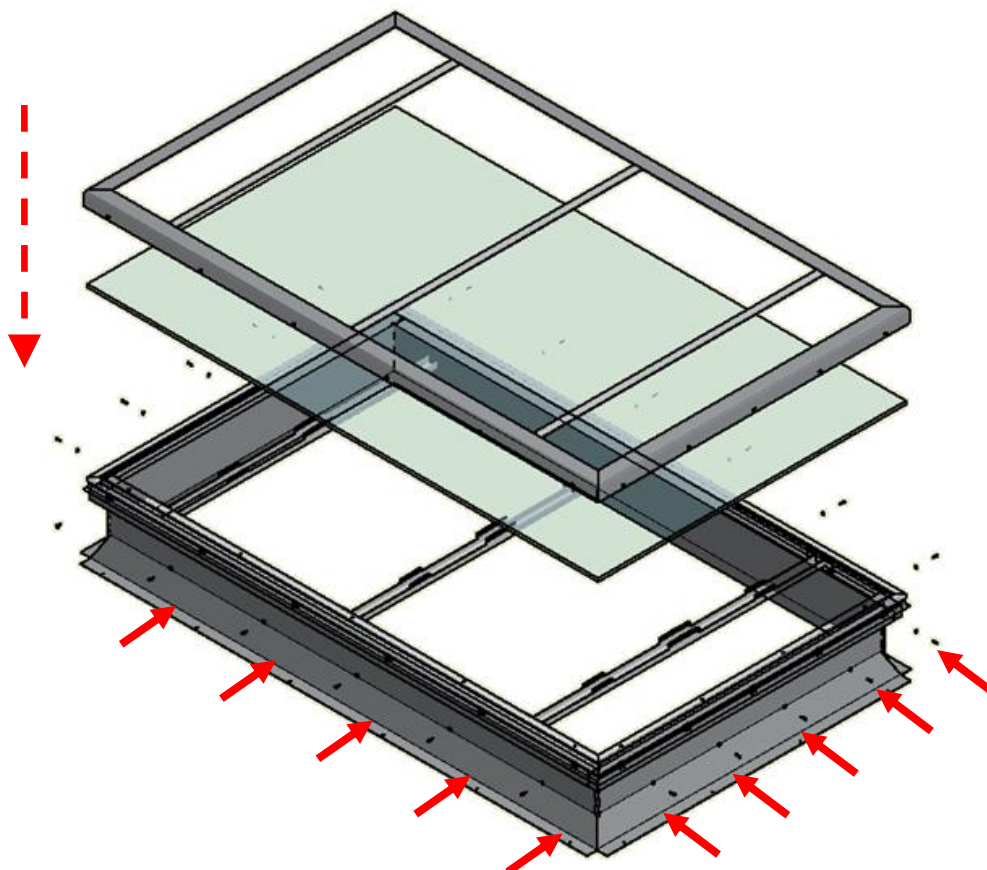

Fig. 46. Base of the FIX skylight with installed PVC top flange of base equipped with crossbeams and a PES 20x10 gasket.

5.2.5. Assembly of the ventilation vent

The first stage of the assembly of the ventilation vent, delivered in parts, is the assembly of the base (see chapters 5.2.1. and 5.2.2.). Then install the actuator bracket, actuator and leaf. Install the leaf according to the rules presented in section 5.2.3. with the difference that the vent has one long hinge on one side of the base. In the last phase of hammering, if there is a very high resistance to hammering the connector, you can move the leaf (open / close) to facilitate assembly. Connect the actuator to the bracket in the crossbeam of the leaf. After completing the assembly and checking if it works properly, put a label on the side of the vents base, near one of the corners. Remove the protective films from the PVC profiles of the vent and the filling.

The drawing below shows the details of making the ventilation vent.

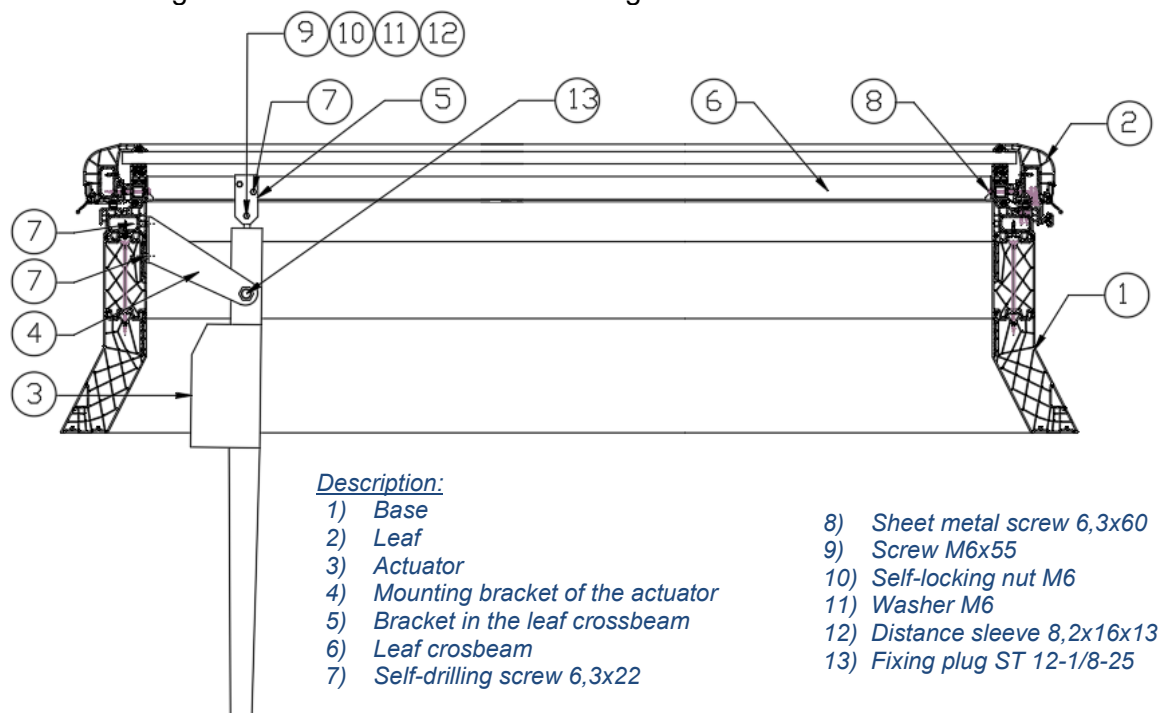
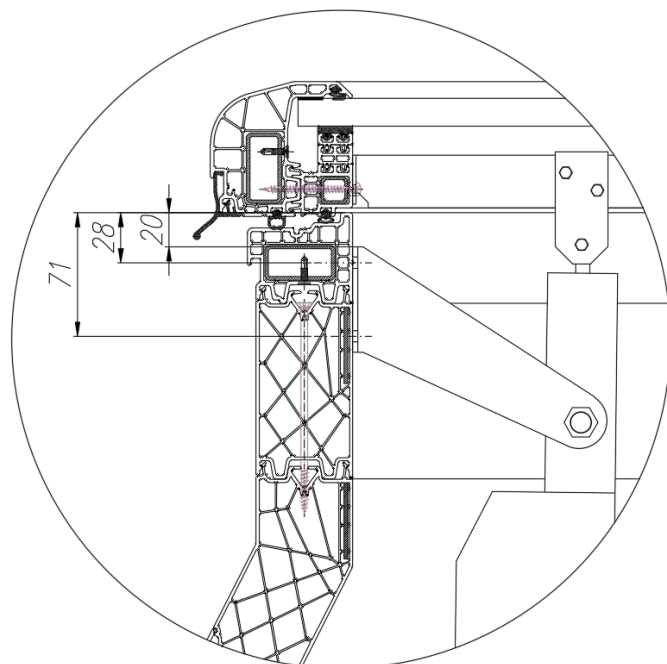

Fig. 47. Cross-section through the mcr ULTRA THERM ventilation vent with a PVC base.



Additional explanation:

Dimension from the top edge of the base:

- 20 mm to the upper edge of the mounting bracket,
- 28 mm and 71 mm to the axis of self-drilling screws.

Fig. 48. Details of mounting the actuator bracket in the ventilation vent.

5.2.6. Assembly of the roof hatch

The first stage of the assembly of the roof hatch, delivered in parts, is the assembly of the steel base from parts (see chapter 5.2.2.).

Then install the brackets in the base as shown in the figure below.

Note: the base has designated holes for mounting these consoles.

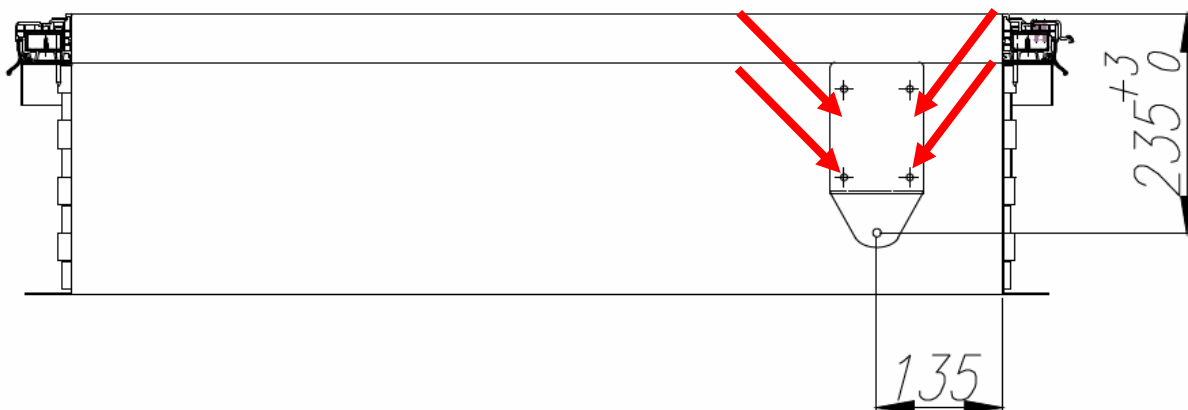

Fig. 49. Mounting the brackets in the base. Fasteners: self-drilling screw 6,3x32.

The next step is to assemble the locking pin, as shown in the figure below.

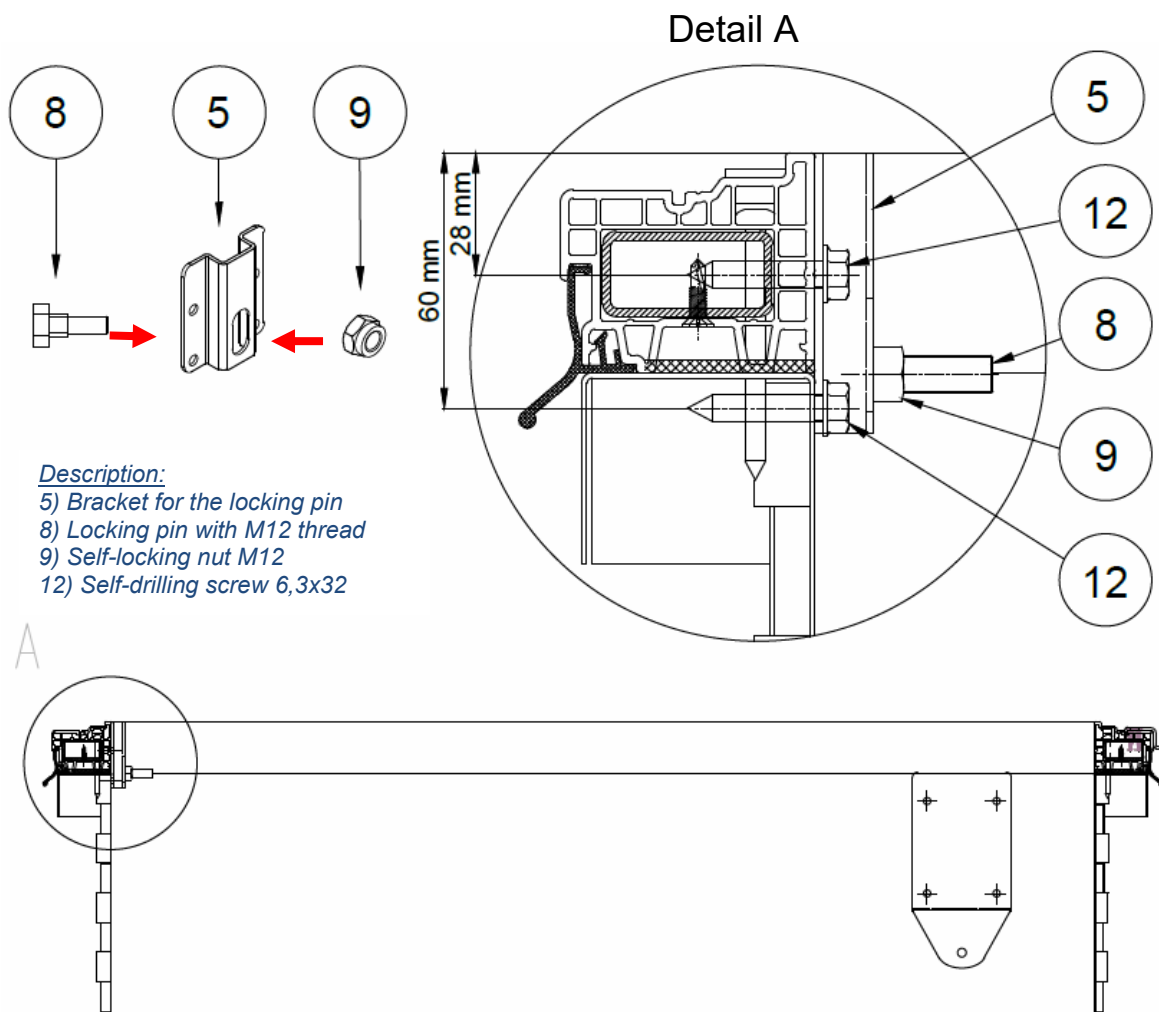

Fig. 50. Locking pin installation.

After installing the locking pin in the base, install the elements in the crossbeam of the leaf, and then connect the leaf to the base. This is shown in the figures below.

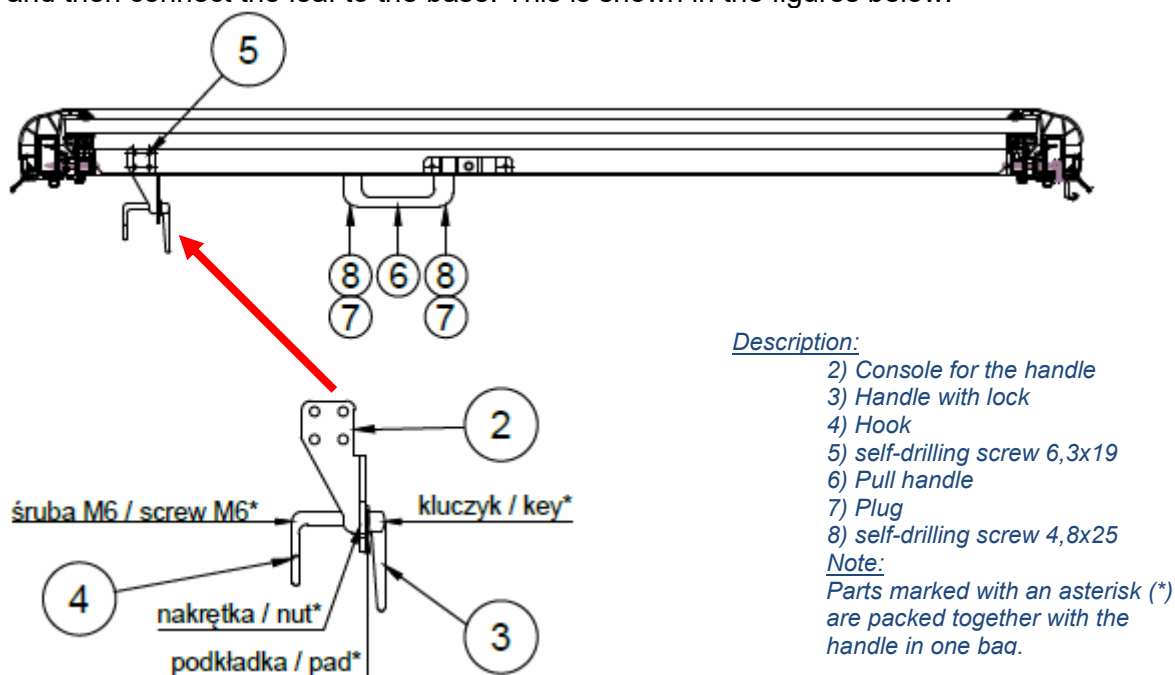

Fig. 51. Assembly of elements in the crossbeam of the leaf.

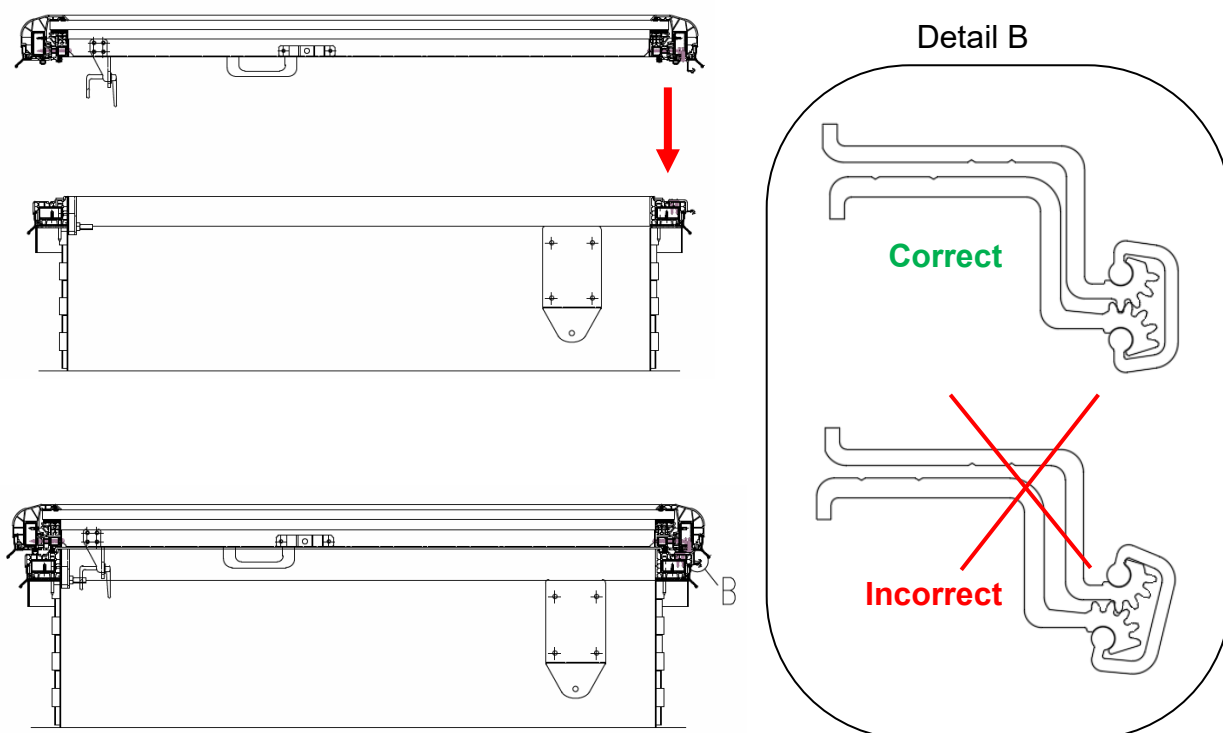

Fig. 52. Installation of the leaf. Detail B shows the correct positioning of the hinge.

When installing the leaf in the roof hatch, use the instructions presented in section 5.2.3. with the difference that the hatch has one long hinge on one side of the base. In the last phase of hammering, if there is a very high resistance to hammering the connector, you can move the leaf (open / close) to facilitate assembly.

The final stage is the installation of the gas springs and the closing of the hatch as shown in the drawings below. After the assembly is completed and operation is checked, attach a label to the side of the hinge base, near one of the corners. Remove the protective films from the PVC profiles of the hatch and from the filling.

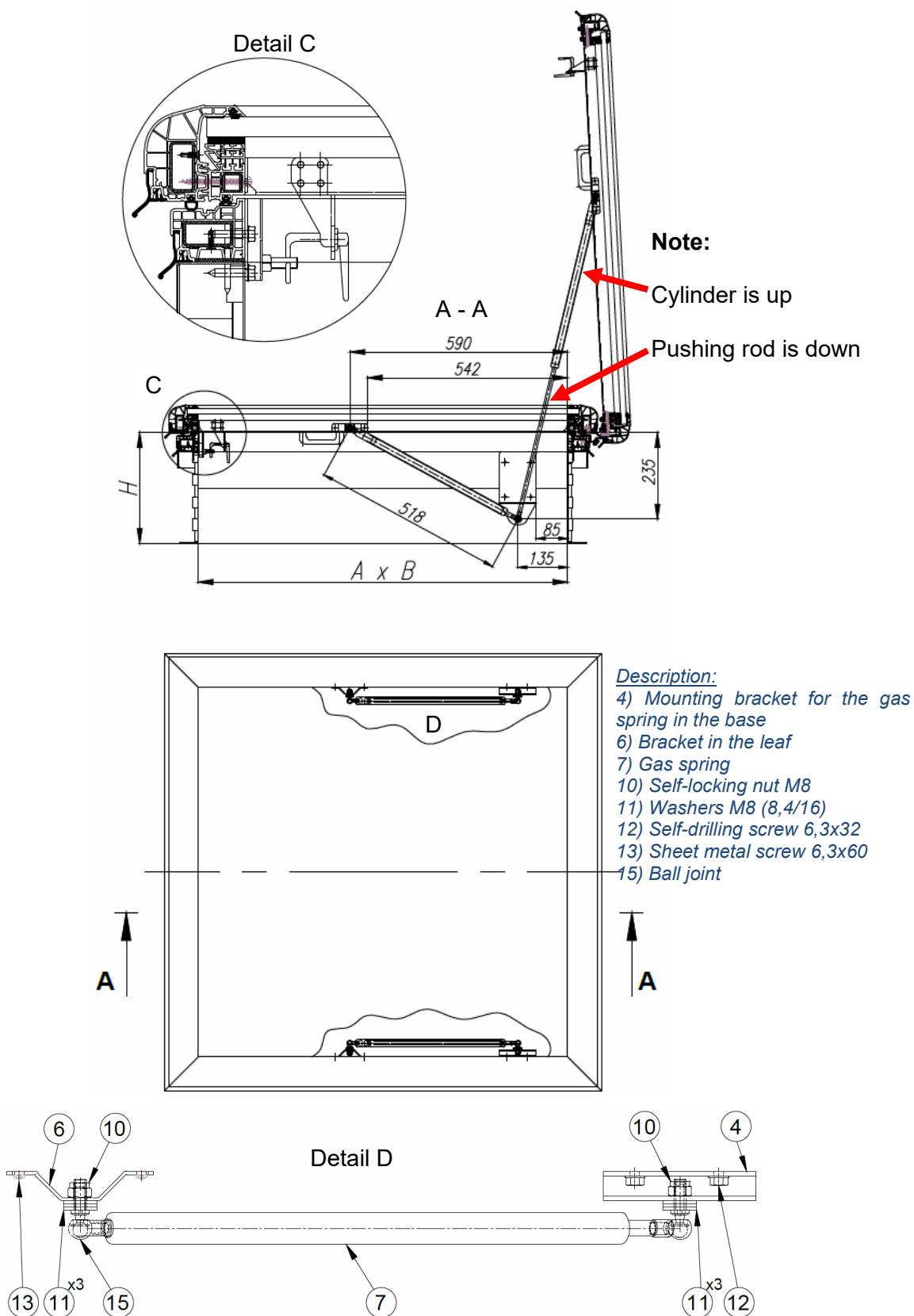

Fig. 53. Installation of gas springs in the roof hatch. Detail C shows the properly closed roof hatch.

5.3. Methods of the mounting the unit on the roof

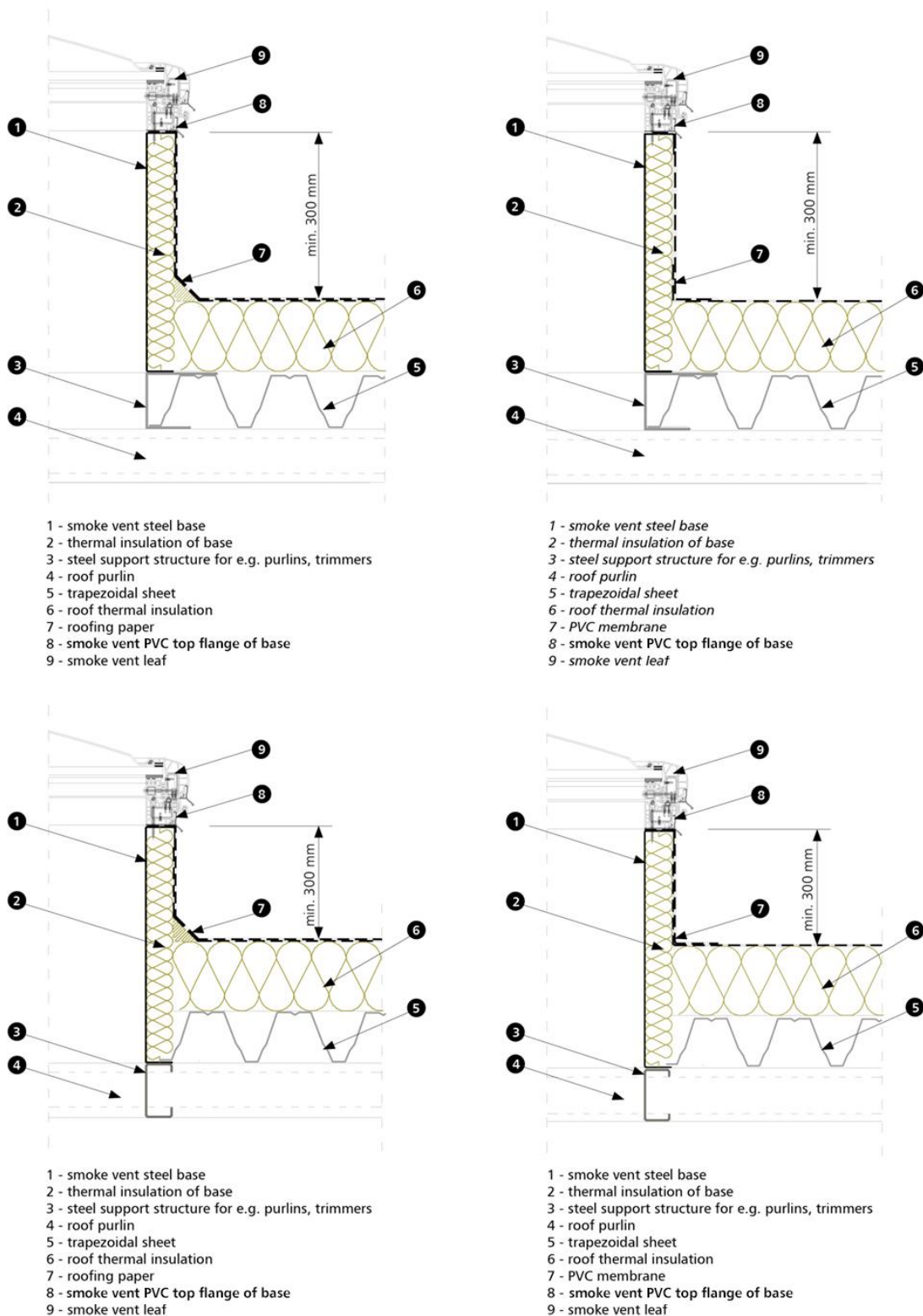

Fig. 54. Skylight with a straight steel base mounted on a steel roof (various variants).

NOTE: It is possible to install the skylight / the hatch on the existing plinth (base) without the use of a dedicated base (pos. 1) in the same way as presented above, but the existing base directly under the top flange of base must be 55^{0.5} mm wide. In this case, the fasteners used to attach the top flange of base to the existing plinth must be selected in accordance with the plinth material.

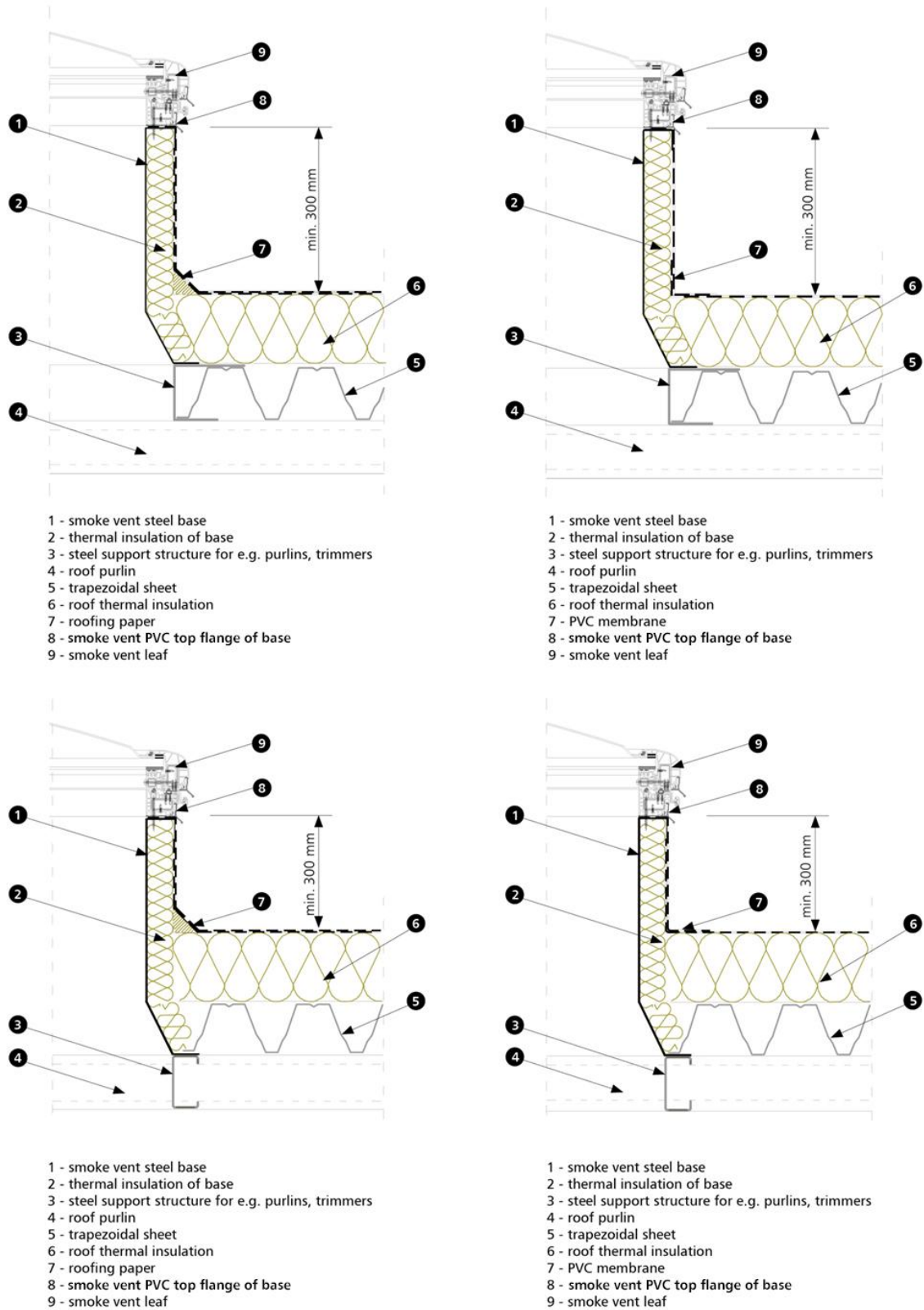
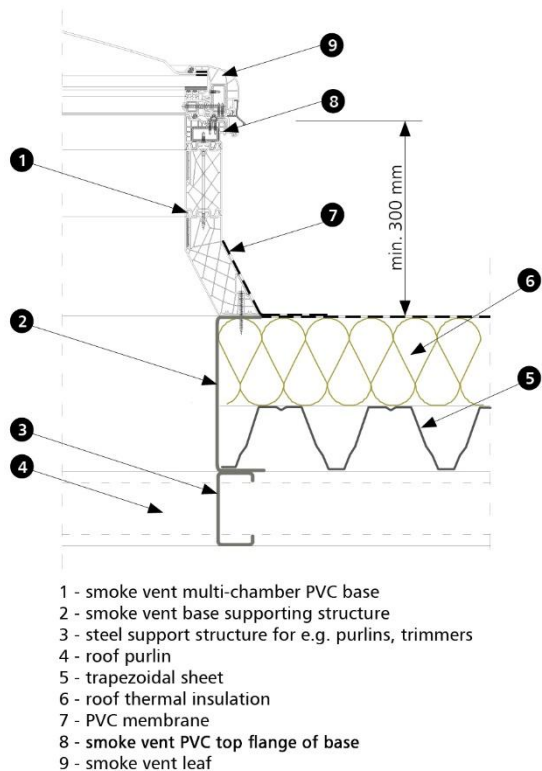
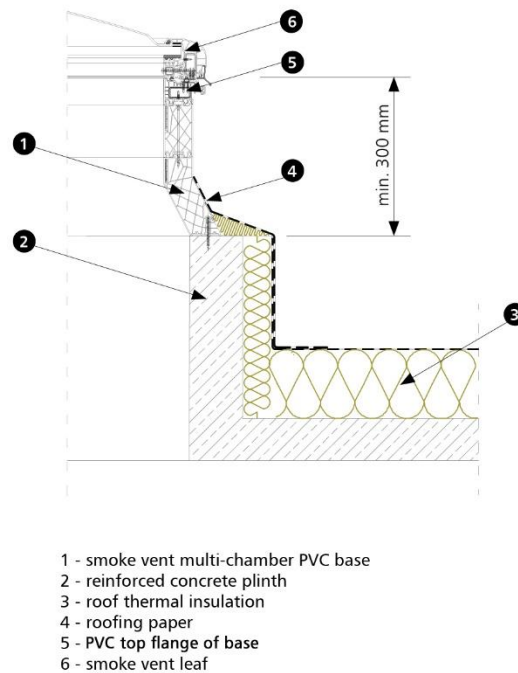

Fig. 55. Skylight with a skew steel base mounted on a steel roof (various variants).



- 1 - smoke vent multi-chamber PVC base
- 2 - smoke vent base supporting structure
- 3 - steel support structure for e.g. purlins, trimmers
- 4 - roof purlin
- 5 - trapezoidal sheet
- 6 - roof thermal insulation
- 7 - PVC membrane
- 8 - smoke vent PVC top flange of base
- 9 - smoke vent leaf

Fig. 56. Skylight with an skew PVC base mounted on a steel roof.



- 1 - smoke vent multi-chamber PVC base
- 2 - reinforced concrete plinth
- 3 - roof thermal insulation
- 4 - roofing paper
- 5 - PVC top flange of base
- 6 - smoke vent leaf

Fig. 57. Skylight with an skew PVC base installed on a reinforced concrete plinth.

CAUTION:

After installing the skylight / ventilation vent / roof hatch, remove the protective foil from the external elements (from the PVC base, leaf, fillings, pressing frame)

6. USAGE OF THE UNIT

Openable skylights, otherwise known as ventilation vents, are electrically controlled. On the other hand, the roof hatches are equipped with mechanical controls (gas springs). The controls are described in the following sections.

If there is a control failure and it is not possible to close the skylight leaf, please contact the service department immediately (see last chapter).

In the event that immediate closing of the leaf is required before the arrival of the service, it is necessary to: disconnect the actuator from the leaf (e.g. disconnecting the actuator from the bracket on the base or disconnecting the eyebolt from the leaf bracket or unscrewing the eyebolt from the actuator), then close the leaf manually and secure against opening.

6.1. Electric control

For transport reasons, the electric actuator for daily ventilation is usually not fitted at the factory. It should be mounted in the actuator mounting bracket using the ST12-1/8 fixing plugs (for the Exxx-230 actuator), M8x8/Ø12x13 fixing plugs (for the VN1 230 V~ actuator) or threaded bolts (JMB actuators) supplied with the actuator. The actuator is equipped with an eyebolt through which it connects to the leaf bracket. It is recommended to secure the ST12-1/8 and the M8x8/Ø12x13 fixing plugs against loosening with Loctite 243 or similar.

It is recommended to use a weather monitoring unit in the ventilation control system, e.g. mcr P054, which automatically closes open skylights in case of strong wind or rain, in order to protect the user's property and skylight structure from damage.



Fig. 58. Electric rack actuator for ventilation control (type Exxx-230 V~).

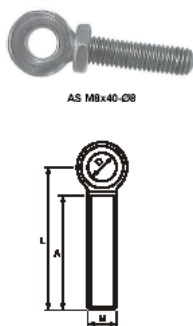
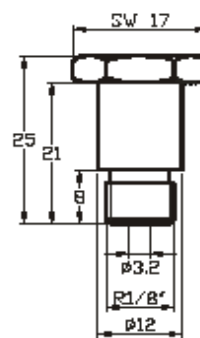

Fig. 59. Eye bolt.



ST 12-1/8

Fig. 60. Fixing plug ST12-1/8.



Rys. 61. Electric rack actuator for ventilation control (typ VN1 230 V~).

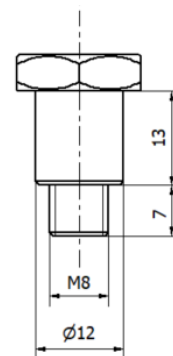

Rys. 62. Fixing plug M8x8/Ø12x13.

The type Exxx-230 V~ rack actuator has two circuits:

- 1) working circuit - controlling the direction of movement (wires: black/brown – blue),
- 2) signaling circuit (wires: 2 x white; signaling in the open position of the actuator: voltage-free contact).

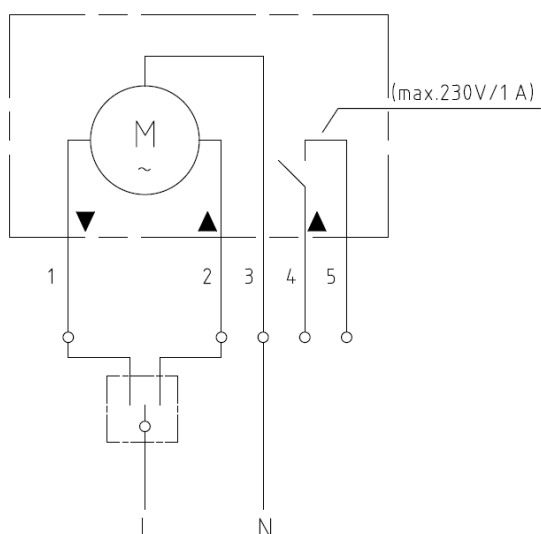

Nr	Colour of the wire
1	BLACK
2	BROWN
3	BLUE
4	WHITE
5	WHITE

Fig. 63. Electrical diagram of the E-xxx-230 V~ type actuator.

The type JMBB-500-300-LA rack actuator has two circuits:

- 1) working circuit - controlling the direction of movement (wires: brown/black1 – blue),
- 2) signaling circuit (wires: black2/black3, signaling in the open position of the actuator: voltage-free contact).

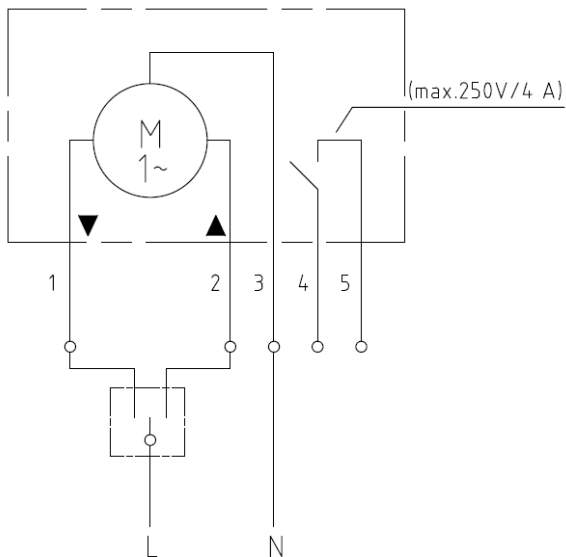

Nr	Colour of the wire
1	BROWN
2	BLACK 1
3	BLUE
4	BLACK 2
5	BLACK 3

Fig. 64. Electrical diagram of the JMBB-500-300-LA rack actuator.

The type VN1 230 V~ rack actuator has two circuits:

- 1) working circuit - controlling the direction of movement (wires: brown/black – blue),
- 2) signaling circuit (wires: white/grey)

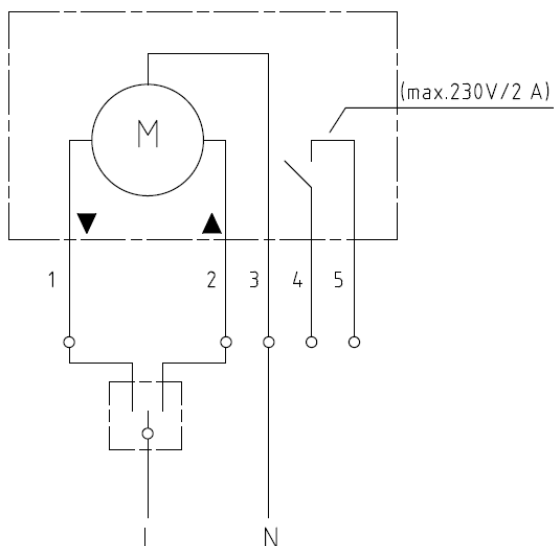

Nr	Colour of the wire
1	BROWN
2	BLACK
3	BLUE
4	WHITE
5	GREY

Rys. 65. Electrical diagram of the VN1 230 V~ rack actuator.

6.2. Mechanical control

To open the mcr ULTRA THERM roof access hatch, unlock the latch (using the key), turn the handle, and open the leaf fully.

The gas springs, mounted to the brackets located on the side walls of the openable skylight hatch base, assist with opening; however, upon releasing the handle lock they do not independently lift the hatch leaf on their own.

To close the device, close the leaf, turn the handle, and lock the latch (using the key).

When using the hatch, exercise caution and support the leaf during opening and closing. After exiting the hatch onto the roof, close the hatch leaf. If the leaf needs to remain open, secure it against unintended closure, especially during wind gusts.

During strong wind gusts, keep the hatch leaf closed.

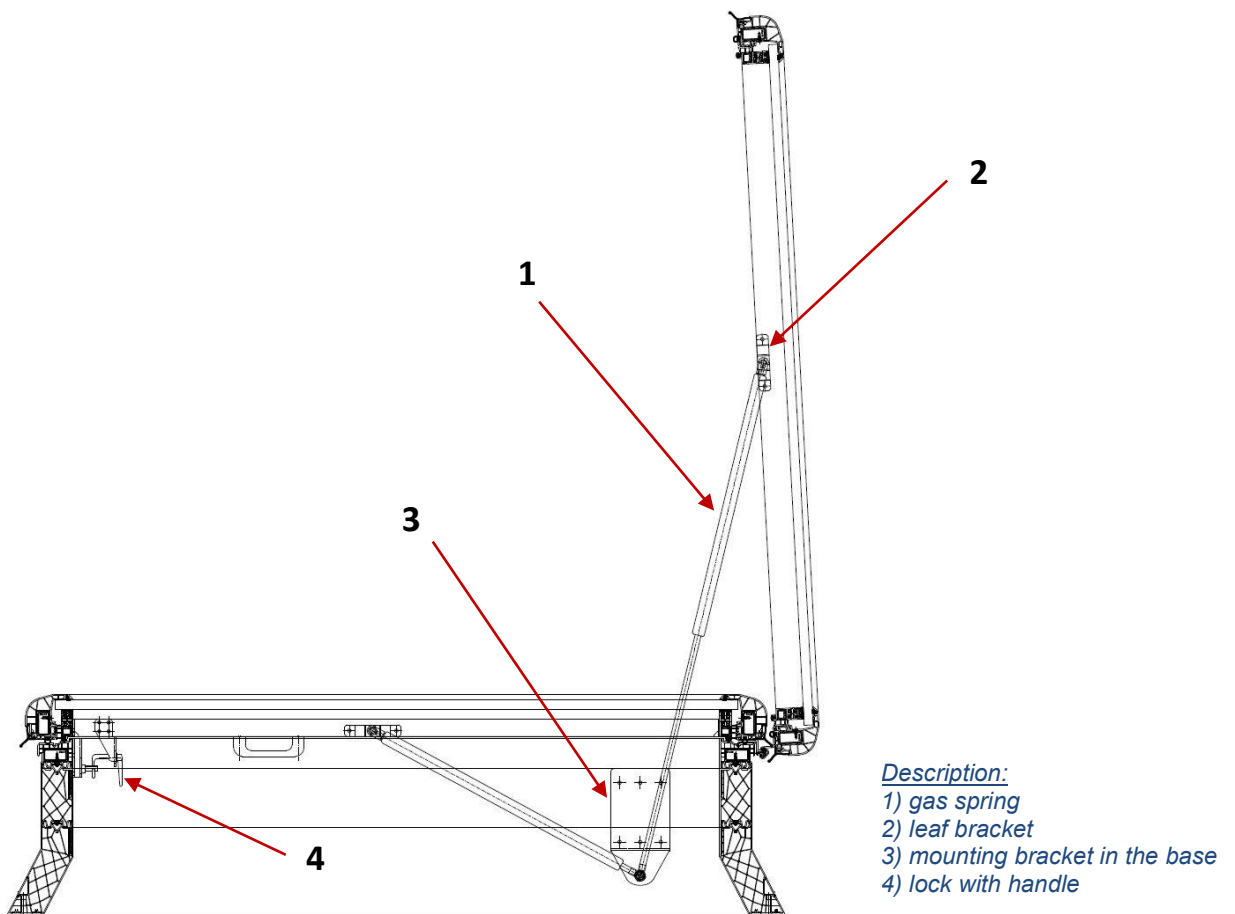

Fig. 66. Roof hatch with gas springs.

6.3. Notes on operation

CAUTION

It is forbidden to use salt to remove snow from roofs on which mcr ULTRA THERM skylights are installed - it may discolor and damage polycarbonate panels, acrylic domes or aluminum profiles. Damage to the mcr ULTRA THERM skylights caused in this way shall not constitute grounds for a complaint.

At slight roof slopes, a certain amount of rainwater may remain on the filling along the edge of the leaf. This phenomenon does not pose a risk of water leakage from the leaf to the inside, because the combination of the PVC leaf and the filling ensures tightness. Residual water will evaporate naturally.

Due to natural processes, condensation may occur in the chambers of polycarbonate sheets. It is manifested most often by the appearance of a mist or, in the case of strong moisture, with clear drops. If air exchange is provided by diffusion between the air inside the chambers and the outside air, after some time the humidity in both areas will even out and the visual effects described above will disappear.

The condensation of water vapor does not affect the service life of the material or the quality of the product.

7. MAINTENANCE

Maintenance of units should be carried out in compliance with all the necessary health and safety rules, in particular those related to working at height, using appropriate personal protective equipment.

During operation, it is necessary to periodically maintain and service the installed units. Service and maintenance are performed by an authorized service team of Mercor Light&Vent. The time between service inspections is 6 months. In between inspections, the following actions are recommended by the user:

1. Checking the condition of electrical connections, paying particular attention to mechanical damage.
2. Checking the condition of the actuator consoles if they are securely fastened.
3. Check the condition of the hinge connector: whether it is not moved.
4. Check if the pressing frame holding the leaf filling is securely fastened, in case of loosening proceed according to point 7.
5. Periodic cleaning of the surfaces of polycarbonate plates and domes:
for cleaning, use a sponge or a soft cloth and lukewarm water with the addition of mild cleaning agents commonly used in the household. The plates cannot be scrubbed with brushes and sharp objects. It is not allowed to use abrasives, strongly alkaline, solvents, etc. In doubtful cases, test the cleaning agent on a sample or a small area.

8. WARRANTY AND SERVICE TERMS

1. Mercor Light&Vent grants a 12-month quality guarantee for equipment, starting from the date of purchase, unless the agreement provides otherwise.
2. Each defect under guarantee should be reported to a local representative of Mercor Light&Vent immediately, i.e. within 7 days of its discovery.
3. Applications can be made by phone at +48/ 58 341 42 45, by email to claim@mercor.com.pl or by sending a letter to: Mercor Light&Vent, Grzegorza z Sanoka 2, 80-408 Gdańsk, Poland.
4. If during the term of guarantee any physical defects of the equipment become evident, Mercor Light&Vent shall remove them within 21 days of the written notification, subject to paragraph 5.
5. Mercor Light&Vent reserves the right to lengthen the repair time in the event of complicated repairs or those that require non-standard sub-assemblies [elements] or spare parts to be purchased.

6. Liability under the Guarantee covers only defects resulting from causes inherent in the equipment sold.
7. In the event of defects resulting from inappropriate operation of the equipment or due to other reasons stated in par. 6, the Buyer/ Guarantee Holder shall bear the costs of their removal.
8. In accordance with the generally accepted practice, the guarantee does not cover:
 - damages and breakdowns of the equipment due to inappropriate operation, user's interference, lack of maintenance or periodic servicing;
 - equipment damages resulting from causes other than those that Mercor Light&Vent is responsible for, in particular: acts of God such as torrential rainfall, flood, hurricane, flooding, stroke of thunder, overvoltage in the mains, explosion, hail, fall of aircraft, fire, avalanche, landslide and secondary damages due to the above-listed causes. Torrential rain is defined as rain with an efficiency index of at least 4 (or 5 in Chomicz scale or torrential rain grade IV (A₄)). Should it be impossible to determine the index mentioned in the previous sentence, the actual condition and the degree of damage at the place of its origin proving that it is the consequence of torrential rain will be considered. Hurricane is defined as wind blowing at the speed of at least 17,5 m/s (damages are deemed to have been caused by hurricane if the effects of hurricane have been found in the immediate neighborhood);
 - damages due to failure to immediately report the defect discovered;
 - worsened quality of coating due to the natural ageing process (fading, oxidation);
 - defects due to using abrasive or aggressive cleaning products;
 - damages due to aggressive external factors, especially chemical and biological ones.
 - parts liable to natural wear and tear during operation (e.g. seals) unless a manufacturing fault has occurred;
 - damages due to improper transport, unloading and storage of the device;
 - damages due to installation inconsistent with the OMM and the rules of good construction practice;
 - ingress of dust, particles or solids with the effective grain size below 50 µm into the polycarbonate sheet chambers;
 - condensation in the polycarbonate sheet chambers.
9. Guarantee and warranty is void in the following cases:
 - The Buyer/Guarantee Holder makes design modifications on his own without consulting Mercor Light&Vent,
 - Maintenance or periodic servicing are not done in due time or are performed by unauthorized persons or a service center not authorized by Mercor Light&Vent , or the equipment is operated in the wrong way,
 - Any interference of unauthorized persons – except activities connected with normal operation of the equipment.
10. The Buyer/Guarantee Holder is responsible for proper operation and maintenance of the equipment and for regular (min. twice a year) servicing according to service and maintenance instructions included in OMM.

SERVICING INSPECTIONS:

1. Devices should be subject to periodical servicing inspections every 6 months during the entire period of their operation.
2. The servicing inspections should be performed by companies having adequate authorization of Mercor Light&Vent.
3. On issues related to service please contact a local representative of Mercor Light&Vent

Other conditions:

1. As regards matters not regulated by these "Warranty terms and conditions", the law applicable is Polish law.
2. Any disputes that may arise in connection with the "Warranty terms and conditions" shall be settled through negotiations between the Parties. This provision is not an arbitration clause.
3. If the Parties fail to reach an agreement by negotiation, any disputes arising from or related to the contract shall be settled by the Polish court competent for the seat of the Seller.